

User Guide

Winder



Software for
Mentor

Part Number: SSP-3200-0010

Issue Number: 4

Safety Information

Persons supervising and performing the electrical installation or maintenance of a Drive and/or an external Option Unit must be suitably qualified and competent in these duties. They should be given the opportunity to study and if necessary to discuss this User Guide before work is started.

The voltages present in the Drive and external Option Units are capable of inflicting a severe electric shock and may be lethal. The Stop function of the Drive does not remove dangerous voltages from the terminals of the Drive and external Option Unit. Mains supplies should be removed before any servicing work is performed.

The installation instructions should be adhered to. Any questions or doubt should be referred to the supplier of the equipment. It is the responsibility of the owner or user to ensure that the installation of the Drive and external Option Unit, and the way in which they are operated and maintained complies with the requirements of the Health and Safety at Work Act in the United Kingdom and applicable legislation and regulations and codes of practice in the UK or elsewhere.

The Drive software may incorporate an optional Auto-start facility. In order to prevent the risk of injury to personnel working on or near the motor or its driven equipment and to prevent potential damage to equipment, users and operators, all necessary precautions must be taken if operating the Drive in this mode.

The Stop and Start inputs of the Drive should not be relied upon to ensure safety of personnel. If a safety hazard could exist from unexpected starting of the Drive, an interlock should be installed to prevent the motor being inadvertently started.

General Information

The manufacturer accepts no liability for any consequences resulting from inappropriate, negligent or incorrect installation or adjustment of the optional operating parameters of the equipment or from mismatching the variable speed drive (Drive) with the motor.

The contents of this guide are believed to be correct at the time of printing. In the interests of a commitment to a policy of continuous development and improvement, the manufacturer reserves the right to change the specification of the product or its performance, or the contents of this guide, without notice.

All rights reserved. No parts of this guide may be reproduced or transmitted in any form or by any means, electrical or mechanical including photocopying, recording or by an information storage or retrieval system, without permission in writing from the publisher.

Copyright © 22 November 2005 Control Techniques Drives Ltd

Issue Code: 4

Firmware: V02.08.01

Contents

1	Introduction	5
1.1	Who Should Read This Manual?	5
1.2	Application Overview	5
1.3	Engineering Units used in this software	6
1.4	Sizing the Motor and Drive Module	7
2	Mechanical Installation	8
2.1	Application Module & Mentor	8
2.1.1	Application Module	8
3	Electrical Installation	9
3.1	Mentor	9
3.1.1	Control	9
3.2	Power / Motor Connections	9
3.3	Connector Location	10
3.3.1	Mentor Control Terminal Connections	10
3.3.2	Application Module Connections	11
3.4	Analog Set points and Feedbacks	12
3.4.1	Specification	12
3.4.2	Mentor Analog I/O Allocation	13
3.4.3	Typical Analog Set-point & Feedback Connection Diagram	14
3.5	Digital I/O	15
3.5.1	Specification	15
3.5.2	Polarity of Logic and I/O Address Parameters	16
3.5.3	Mentor Digital I/O Allocation	17
3.5.4	Typical Digital I/O Connection Diagram	18
3.6	Winder Drive Configurations	22
4	Software Installation	23
4.1	CTIU Software	23
5	Getting Started	24
5.1	Mentor	24
5.2	Winder Control	25
5.3	Operating Procedures	27
5.3.1	General Requirements	27
5.3.2	Direction of Rotation	28
5.3.3	Operational Functions	29
5.4	Basic I/O Configurations	31
5.4.1	Basic configuration for a Mentor Torque controlled winder	31
5.4.2	Basic configuration for a Quantum Torque controlled winder	31
5.4.3	Basic Configuration for a Speed controlled winder	32
5.4.4	Basic Configuration for a Quantum Speed controlled winder	32
5.5	Configuration of Parameters	33
5.5.1	Alternative Parameter selection	34
5.5.2	Classified Parameter Listing	36
5.5.3	Saving Parameters	45

6	Commissioning Sequence	46
7	Functional Description	47
7.1	Overview	47
7.1.1	Standard or Back EMF Winder Control	48
7.1.2	Speed and Tension Referencing overview	51
7.1.3	Diameter Calculation overview	52
7.1.4	Tension Torque overview	53
7.1.5	Inertia and Friction Torque Compensation overview	54
7.1.6	Speed Referencing overview	55
7.2	Set Point Data Scaling & Selection	56
7.2.1	Use of Current Limit functions	57
7.2.2	Control Sequencing	57
7.2.3	Line Speed Reference Sources	59
7.2.4	Length Count	60
7.2.5	Reference polarity and direction of rotation	60
7.2.6	Speed Referencing (Torque Mode)	62
7.2.7	Speed Referencing (Speed Mode)	62
7.2.8	Tension Referencing (Torque Mode)	63
7.2.9	Diameter Referencing (Direct measurement)	63
7.3	Diameter Measurement and Calculation	64
7.3.1	Diameter Preset	66
7.3.2	Diameter Slew Limiting	67
7.3.3	Diameter Hold	68
7.3.4	Acquire Diameter	69
7.3.5	Slack Web Detection	69
7.3.6	Coupling	70
7.3.7	Non Volatile Diameter Storage	70
7.3.8	Web Break Detection	70
7.3.9	Loss of Analog Diameter feedback	71
7.4	Taper Tension	71
7.5	Torque Compensation functions	72
7.5.1	Loss Compensation	73
7.5.2	Inertia Compensation	76
7.5.3	Flux Compensation	77
7.6	Using the Field Current Profiler in Back EMF Mode.	78
7.7	Speed Control functions	82
7.7.1	Speed Offset for Torque Control	82
7.7.2	Dancer centring Routine	83
7.8	PID Control	84
7.8.1	Load Cell Calibration	84
7.8.2	Dancer calibration	86
7.8.3	PID Description	87
7.8.4	PID Operation (Torque Mode 15.34 = 0)	87
7.8.5	PID Operation (Speed Mode 15.34 = 1)	88
7.8.6	PID Output Profiling	88
7.8.7	Proportional Gain Kp (2.08 or 70.14)	89
7.8.8	Integral Gain Ki (2.09 or 70.15)	89
7.8.9	Differential Gain Kd (2.10 or 70.16)	89
7.9	Reversing Mill Applications	90
7.10	Turret Winder Features	91
7.10.1	Torque Memory Function	91
7.10.2	Index Torque Boost Function	92
7.10.3	Speed Boost Function	92
7.10.4	At Line Speed Function	92
7.10.5	Lay On Roll Torque Boost Function	92
7.11	Communications Watchdog	93

8	Parameter Descriptions	94
8.1	Mentor Standard Parameters	94
8.1.1	Menu 1	94
8.1.2	Menu 2	97
8.1.3	Menu 3	98
8.1.4	Menu 4	99
8.1.5	Menu 5	100
8.1.6	Menu 6	100
8.1.7	Menu 7	101
8.1.8	Menu 8	102
8.1.9	Menu 11	105
8.1.10	Menu 13	106
8.1.11	Menu 14	106
8.2	Mentor Non-Standard Parameters	107
8.3	Application Parameters	112
8.3.1	Menu 15	112
8.3.2	Menu 16	123
8.3.3	Menu 70	131
8.3.4	Menu 71	144
8.3.5	Menu 72	148
8.3.6	Menu 73	149
9	Advanced Features	150
9.1	Serial Communications	150
9.1.1	Control Word	150
9.1.2	Status Word	154
9.1.3	CTNet Configurable Input Cyclic Data	156
9.1.4	CTNet Output Data	156
10	Parameter Set-up Tools	158
10.1	Mentorsoft	158
10.2	Browser	159

11	CTIU – Operator Panel	160
11.1	Introduction	160
11.2	Software Version	161
11.2.1	Configuration file version	161
11.3	Mechanical Installation	161
11.3.1	Panel Cut-out Detail	161
11.4	Electrical Installation	162
11.4.1	CTIU110 Rear View	162
11.4.2	Serial Communications Cable Connections	163
11.5	Mentor set-up	164
11.5.1	CTIU110 Configuration of the RS-485 Port	164
11.6	Operation Button Selection Actions	165
11.7	Navigation	165
11.7.1	Parent Menu Pages Navigation	166
11.7.2	Sub Menu Pages Navigation	166
11.8	Operators Screens Description	167
11.8.1	Top Level Screen and Functionality	167
11.8.2	Diagnostic Screens	168
11.9	Splash Screens	171
11.9.1	Application Page (1st Page)	171
11.9.2	Software Version Page (2nd Page)	171
11.10	Parameter Save	172
11.10.1	Parameter Save Main Screen	172
11.10.2	Parameter Save Acknowledgement Screen	172
11.11	Trip & Alarm indication	173
11.11.1	Alarm Pages	174
11.12	CTIU Function Keys Allocation	175
11.12.1	Global Control Function Keys	175
11.12.2	Local Function Keys	175
12	Quick Reference	176
12.1	Mentor	176
12.1.1	Relevant Parameter	176
12.1.2	I/O Parameters	177
12.2	Application	178
12.2.1	Mentor Parameters Used as Application Parameters	178
12.2.2	Menu 15	179
12.2.3	Menu 16	181
12.2.4	Menu 70	183
12.2.5	Menu 71	186
12.3	Categorised Winder Parameters	187
12.3.1	Common Parameters	187
12.3.2	Diameter	189
12.3.3	Speed Parameters	191
12.3.4	Torque Parameters	191
12.3.5	Tension	192
12.3.6	PID	193
12.3.7	Field Controller	193
12.3.8	Compensation	194
12.3.9	Digital Control Parameters	195
13	Documentation Reference	196

1 Introduction

1.1 Who Should Read This Manual?

This manual is intended to assist the engineer in commissioning the application software, and should be read in conjunction with the documentation that is supplied with the drive and other associated hardware. The safety systems that are required to prevent risk of injury to persons operating or maintaining the machine are not discussed in this manual. The engineer must be familiar with and able to implement the required safety systems. This manual assumes that the engineer is familiar with relevant Control Techniques products and understands the requirements for the application.

If you do not feel confident of the above, then you should contact your local Control Techniques drive centre or distributor to obtain service / advice.

1.2 Application Overview

The Control Techniques Centre Wind software package has been developed with the objective of simplifying the set up and commissioning of centre wind systems. It is designed to handle a wide range of centre wind applications and is suitable for both rewind and unwind functions. It can be configured to operate in open or closed loop torque mode with feedback from a load cell or dancing roll, or in closed loop speed control mode with feedback from a dancing roller or load cell.

Features provided within the package include:

- All Data entry for set up in Engineering Units
- Option of Metric or U.S. Standard Units.
- Set point data in digital or analog format
- Operation using armature voltage spillover or Back EMF winder mode
- Dedicated process data registers allow high speed data input via field bus
- Tension control using Torque Mode or Speed Mode
- PID trim in conjunction with load cell or dancer feedback
- Diameter calculation using Speed ratio or Lap count
- Option within lap count for operation with traverse systems
- Alternative of direct diameter measurement via analog input.
- Inertia compensation for fixed and variable inertia components
- Fixed and dynamic loss compensation
- Tension profiling to achieve Taper with adjustable taper start point
- Linear or Hyperbolic profiles available
- Automatic adjustment to suit both constant torque and constant power motors
- analog or serial data input or a combination of both.
- User configurable I/O allows use with discrete control devices MMI or PLC via parallel or serial interface.
- Web break detection
- analog output for Dancer pressure regulating systems

1.3 Engineering Units used in this software

Input & display data	Metric 16.31 = 0	US Standard 16.31 = 1
Diameter	Millimetres	Tenths of an inch
Width	Millimetres	Inches
Density	Kg / m ³	Pounds per cubic foot
Inertia	Kg m ²	Pounds feet ²
Gauge	Microns	Thousandths of inch
Line Speed	Metres per minute	Feet per minute
centring speed	Centimeters per minute	Inches per minute
Acceleration	Metres per minute per second	Feet per minute per second
Tension	Newtons	Pounds
Torque	Newton metres	Pounds feet

NOTE The main algorithms of this software operate in Metric units, therefore when US standard units are used each applicable parameter is converted internally to metric. Due to the conversion factors used, this introduces limitations with the minimum settings of some of the parameters.

For example:

Line speed minimum setting is 4ft/min

(Conversion factor 3.28ft/min to 1m/min)

ANY VALUE SET BELOW WILL BE 0.

1.4 Sizing the Motor and Drive Module

Winder motors should always be sized from knowledge of the required winding tension and line speed

$$\text{Winding tension power (kW)} = \frac{\text{Line speed} \times \text{Total tension pull}}{60000}$$

Where line speed is in Metres per minute and Tension is in Newtons.

Or, using US Standard units

$$\text{Winding tension power (HP)} = \frac{\text{Line speed} \times \text{Total tension pull}}{33000}$$

Where line speed is in feet per minute and Tension is in pounds force.

If constant torque control is to be employed then the motor and converter should be rated

$$\text{Motor/Convertor (kW)} = \text{Winding tension power (HP)} \times \frac{\text{Maximum diameter}}{\text{Minimum diameter}}$$

$$\text{Motor speed (r/min)} = \frac{\text{Line speed (m/min)} \times \text{Gear ratio}}{\text{Pi} \times \text{Minimum diameter (metres)}}$$

This will ensure that the drive can produce the torque required at maximum diameter and the speed required at minimum diameter.

Constant power applications are best specified by stating, the power and speed requirements at both ends of the diameter range. If a combined constant power / constant torque application is involved then the speed and power requirement at base speed should also be quoted. If a constant torque region is to be provided ensure that the drive controller is up-rated accordingly.

Any additional power required to overcome transmission losses and provide peaks for acceleration should be added to the above result.

It is essential that the motor and drive are correctly matched to the power requirement of the winder to ensure optimum control resolution.

When the winder is required to operate in Torque control mode it is important that the drive burden resistor be chosen for the maximum anticipated winder current and not to provide a nominal 50% overload availability from the motor.

Winder peak currents may be estimated as follows:

$$\text{Rewinding current} = \text{Tension current} + \text{Loss current} + \text{Accel current}$$

$$\text{Unwinding current} = \text{Tension current} - \text{Loss current} + \text{Decel current}$$

2 Mechanical Installation

NOTE Ensure the Mentor is correctly installed in accordance to the Mentor Installation Manual

2.1 Application Module & Mentor

Isolate the Drive from both AC supply sources.

Insert the Winder Application Module as shown below. Ensure that it is correctly inserted. The module will click firmly into place.

The Mentor must be disconnected from the mains supply before installing or removing an option module.

2.1.1 Application Module

The application card is fitted to the MDA2B card situated behind the hinge down front panel of the drive module as indicated below.

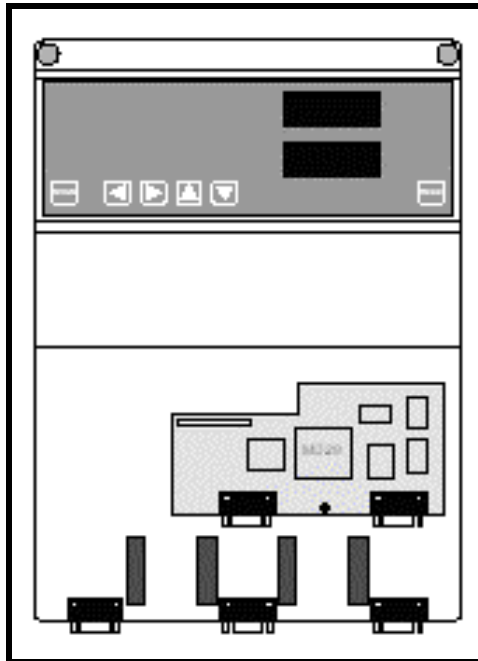

The supplied mounting pillars should be located in the fixing holes provided on the MDA2B. Locate the first few pins of the MD29 into the MDA2B header, then bring the board to the horizontal to engage the rest of the pins. Press firmly downwards until the card clicks onto the support pillars.

Take extra care when fitting or removing the MD29 card on to PL1, excessive force may damage the pin connectors.

3 Electrical Installation

3.1 Mentor

3.1.1 Control

+24V digital supply (Terminal 33)

Supply for external digital signal devices.

Voltage Tolerance:	±10%
Nominal output current:	200mA
Protection:	Short circuit proof

+10V analog supply (Terminal 4)

Supply for external analog signal devices

Voltage Tolerance:	±1%
Nominal output current:	10mA
Protection:	Short circuit proof

3.2 Power / Motor Connections

Please refer to the Mentor documentation for the relevant information regarding:

- Voltage Rating
- Current rating
- Motor Connections
- Encoder / Tachogenerator Connections

3.3 Connector Location

3.3.1 Mentor Control Terminal Connections

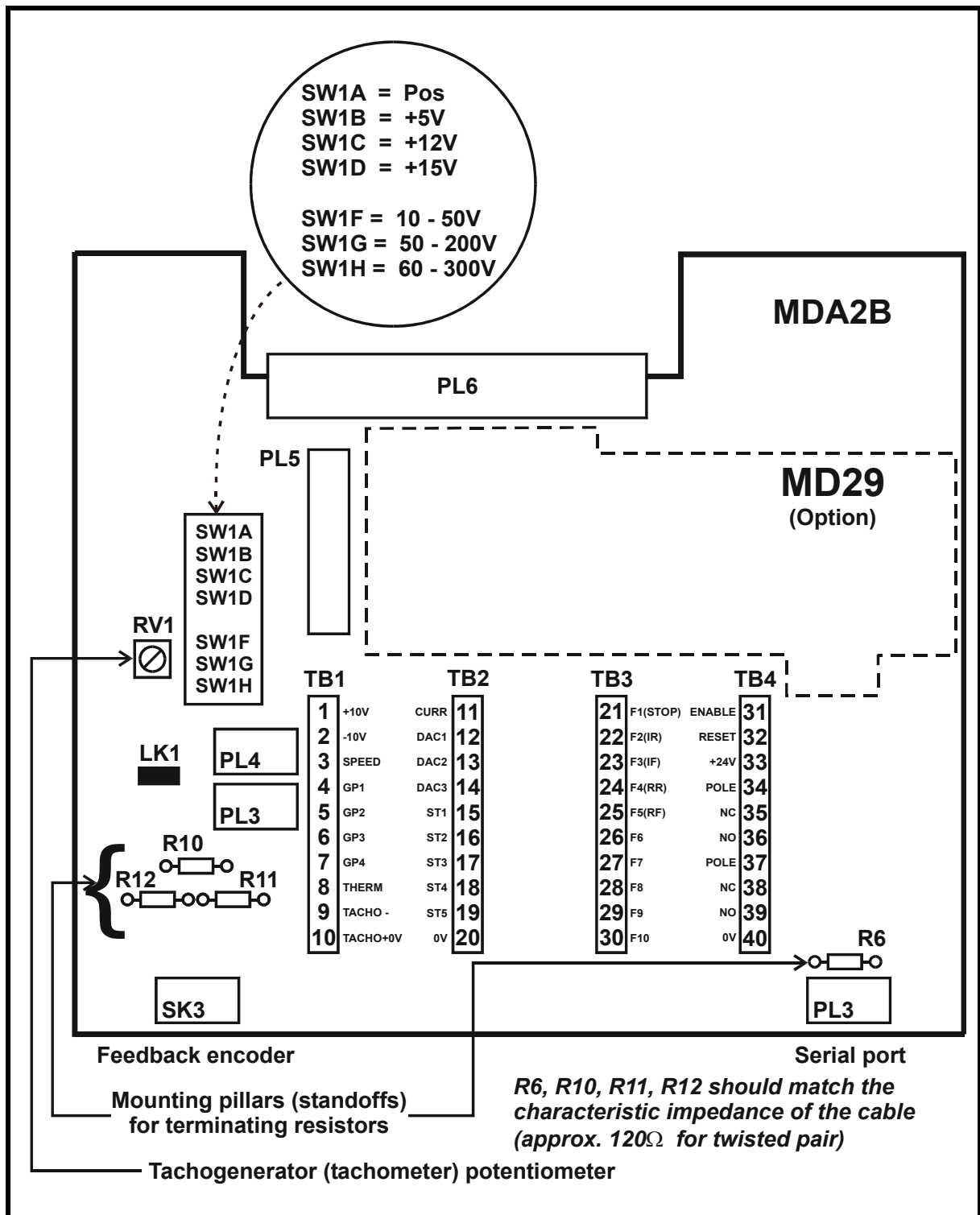

3.3.2 Application Module Connections

Connectors C and D on the Application module are the RS232 programming port (C) and RS485 general-purpose communications port (D) of the MD29, connector A is the CTNet terminal block when supported.

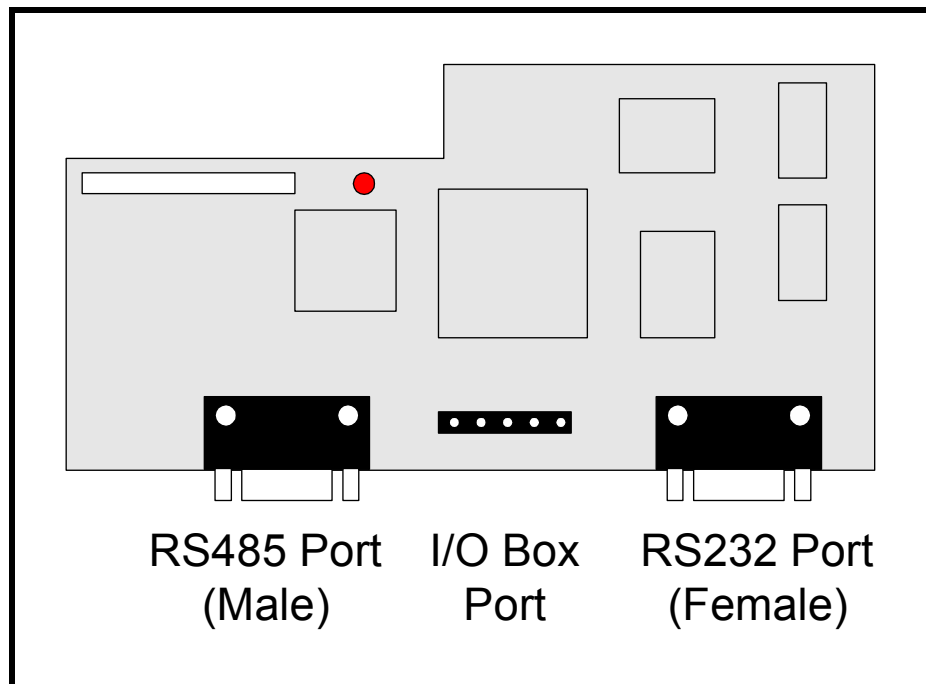

Pin	RS232 Port Allocation(C)	RS485 Port Allocation(D)
1		0v
2	TXD	/TXD
3	RXD	/RXD
4		Digital Input 0 (TTL)
5	0V	Digital Input 1 (TTL)
6		TXD
7		RXD
8		Digital Output (TTL)
9		0V Digital

3.4 Analog Set points and Feedbacks

3.4.1 Specification

Analog Inputs

Specification	Mentor I/O
Max. Input voltage	-10V to +10V (term3 0/4-20ma also)
Input resistance	100 kohm
Absolute Maximum Input	± 24 V with respect to 0 V
Resolution	10-bit plus sign

Analog Outputs

Specification	Mentor I/O
Max. Output voltage	-10V to +10V
Load resistance	> 1 kohm
Protection	Short-circuit proof
Resolution	10-bit plus sign

OTHER INDUSTRIAL SIGNALS

To interface to the Mentor analog inputs with other industrial feedback sources, like resistive sensing PT100, Thermocouples, etc an external signal converter will be required.

3.4.2 Mentor Analog I/O Allocation

In order to simplify set up and avoid the need for additional signal linking parameters the Mentor analog inputs have been pre-assigned. The Mentor analog input pointer parameters will therefore have no effect on the operation of the winder software. The analog input assignment is indicated below.

Parameter	Description	Term No.	Res.
7.05	15.20.0 = 0 Line speed reference 15.20.0 = 1 (Line speed via serial comms) Load cell or dancer F/B	3	12bit+sign
7.01	Tension Set Point	4	10bit+sign
7.02	Taper Set Point	5	10bit+sign
7.03	Diameter set point	6	10bit+sign
7.04	Load cell or dancer F/B	7	10bit+sign
	0v	10	-
	+10Vdc	1	-
	-10Vdc	2	-

Mentor analog inputs on terminal 3 can be configured for voltage (+/-10V) or current signals (0/4-20mA) modes. Refer to parameters 07.26 – 07.28.

NOTE If a line encoder is used for line speed feedback, analog input on Terminal 3 cannot be used for dancer/load cell feedback. This input can only be used for higher resolution tension/position feedback when the line speed is derived via serial communication (parameter 15.20.0=1)

3.4.3 Typical Analog Set-point & Feedback Connection Diagram Example 1 (Referencing for Analog Torque Winder)

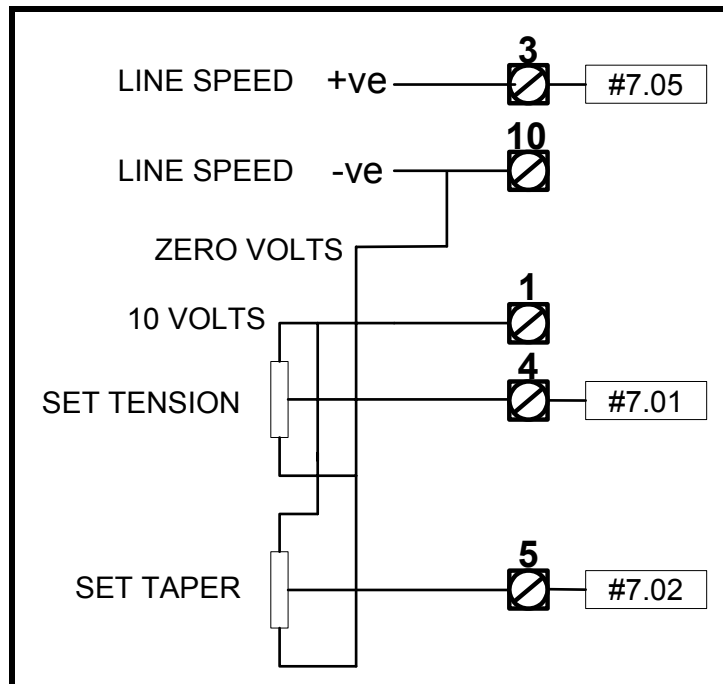

Example 2 (Referencing for Analog Speed Winder)

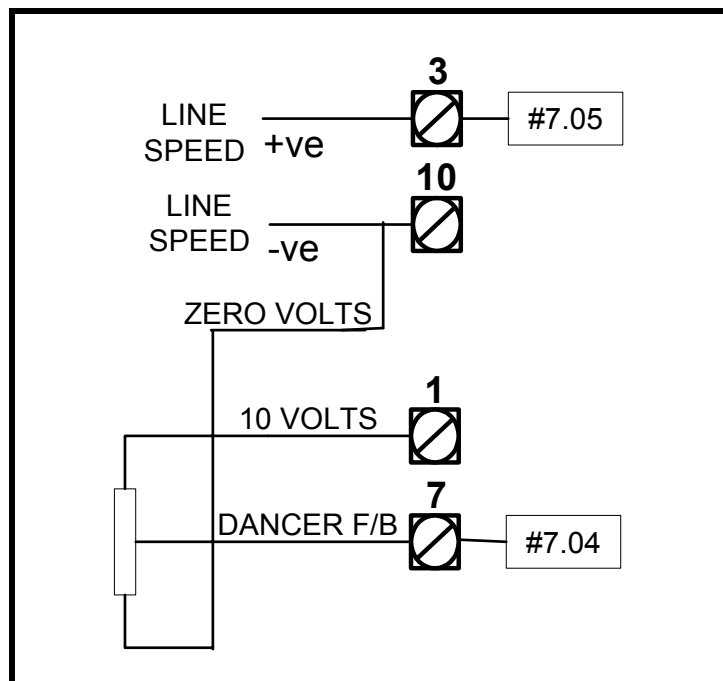

3.5 Digital I/O

3.5.1 Specification

Digital Input/Outputs

Specification	Mentor I/O
Voltage range	- 0V to +24V
Absolute max. Voltage range	-3V to +30V
Logic levels	High: >+15V Low: <+5V
Input impedance	100kOhms
Output current	100mA Open collector
Overload	Short cct proof

Specification	Mentor I/O
Contact Voltage Rating	250Vac
Max Current	2.5A / 250V 5A / 110V

3.5.2 Polarity of Logic and I/O Address Parameters

The logic polarity can be configured for 'Positive Logic (Sink)' or 'Negative Logic (Source)', where 24Vdc supply can be sourced locally from the Mentor (Terminal 33) or from an external power supply.

SW1A OFF = Negative Logic Select (Default)

SW1A ON = Positive Logic Select

MENTOR DIGITAL I/O					
Specification			Parameters		
Term No.	I/O	Ind	Function	Invert	Dest./Source
36-37	Relay	09.06	Prog/ZSR	09.26	09.25
39-40	Relay	10.12	Drive OK	-	-
33	24Vdc	-	-	-	-
40	0Vdc	-	-	-	-
21	Input	08.01	Run permit	-	-
22	Input	08.02	Inch rev	-	-
23	Input	08.03	Inch fwd	-	-
24	Input	08.04	Prog	08.24	08.14
25	Input	08.05	Run	-	-
26	Input	08.06	Prog	08.26	08.16
27	Input	08.07	Prog	08.27	08.17
28	Input	08.08	Prog	08.28	08.18
29	Input	08.09	Prog	08.29	08.19
30	Input	08.10	Prog	08.30	08.20
15	Output	09.01	Prog		
16	Output	09.02	Prog		
17	Output	09.03	Prog	09.20	09.19
18	Output	09.04	Prog	09.22	09.21
19	Output	09.05	Prog	09.24	09.23

3.5.3 Mentor Digital I/O Allocation

The standard Mentor input control functions allocated to terminal 21 – 25 are fixed within the software. The programmable inputs from terminal 26-30 may be used to control the other auxiliary winder functions such as selecting tension on, presetting diameter etc.

If hard wired inputs are not required a control word is provided to allow the user maximum flexibility to define his own I/O mappings from local Terminal I/O or Remote via Fieldbus communications.

A basic system may be set up as listed below.

MENTOR STANDARD I/O			
No	Description	Terminal	I/O
ST6	Zero speed	36 & 37	Output
	Drive OK	39 & 40	Output
F3	Jog forward	23	Input
F2	Jog reverse	22	Input
F5	Line Running	25	Input
F6	Tension On (08.16 = 1523)	26	Input
F7	Preset diameter (08.17 = 1528)	27	Input
F1	Run Permit	21	Input
	Drive enable	31	Input
	+24Vdc, 200mA Supply	33	-
	0v Supply	40	-

3.5.4 Typical Digital I/O Connection Diagram

Mentor torque controlled winder

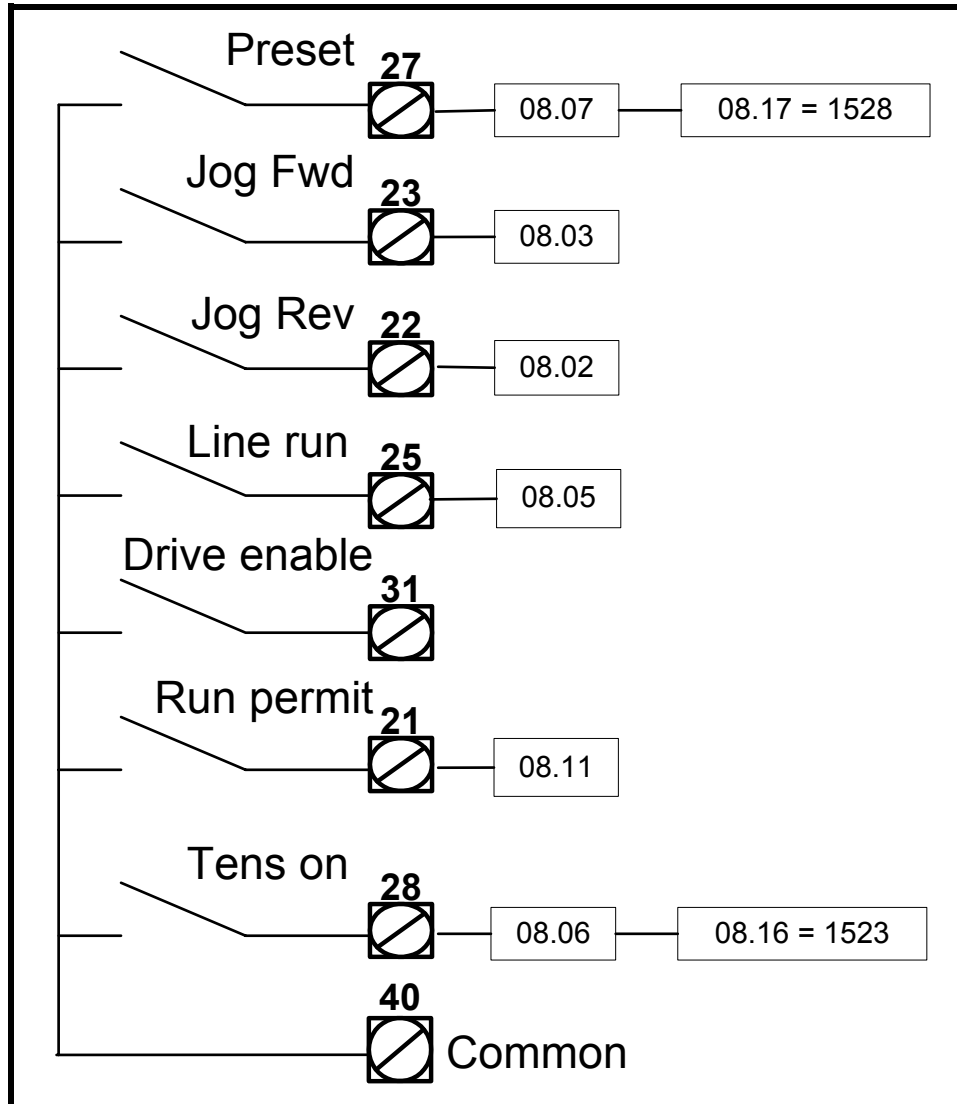

Quantum torque controlled winder

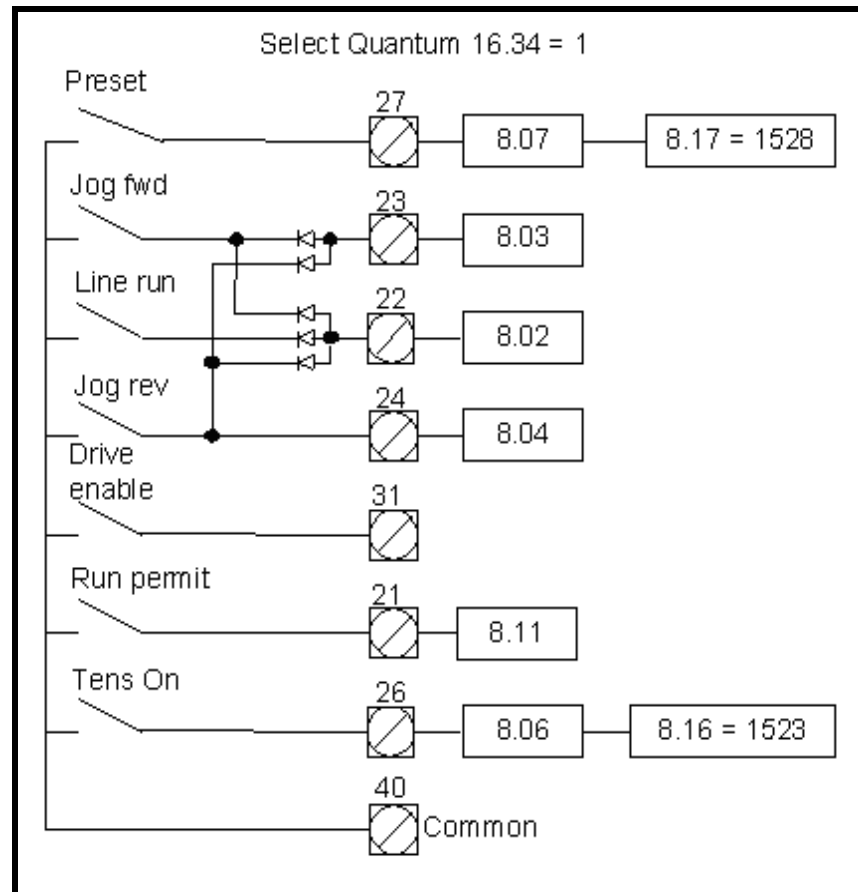

NOTE The sequencing of the digital control inputs is important, the drive enable must be used simply to signal operation of the drive contactor with suitable pilot relay to ensure late make and early break. (N/O contactor pilot and contactor auxiliary contacts in series) connected to terminal 31.

The run permit should be enabled at all times when motion is required but must be enabled after the drive enable. Opening run permit terminal 21 will result in a current limit stop no matter what control inputs have been energised. The drive enable must remain enabled during the stopping period.

Inching and run to line speed functions can be achieved provided the drive enable and the run permit inputs are enabled.

The system logic will not return to a ready to inch or run state until the drive is at zero speed the drive enabled is on and the run permit has been removed.

On no account should terminals 21 and 31 be operated in parallel.

Mentor Speed controlled winder

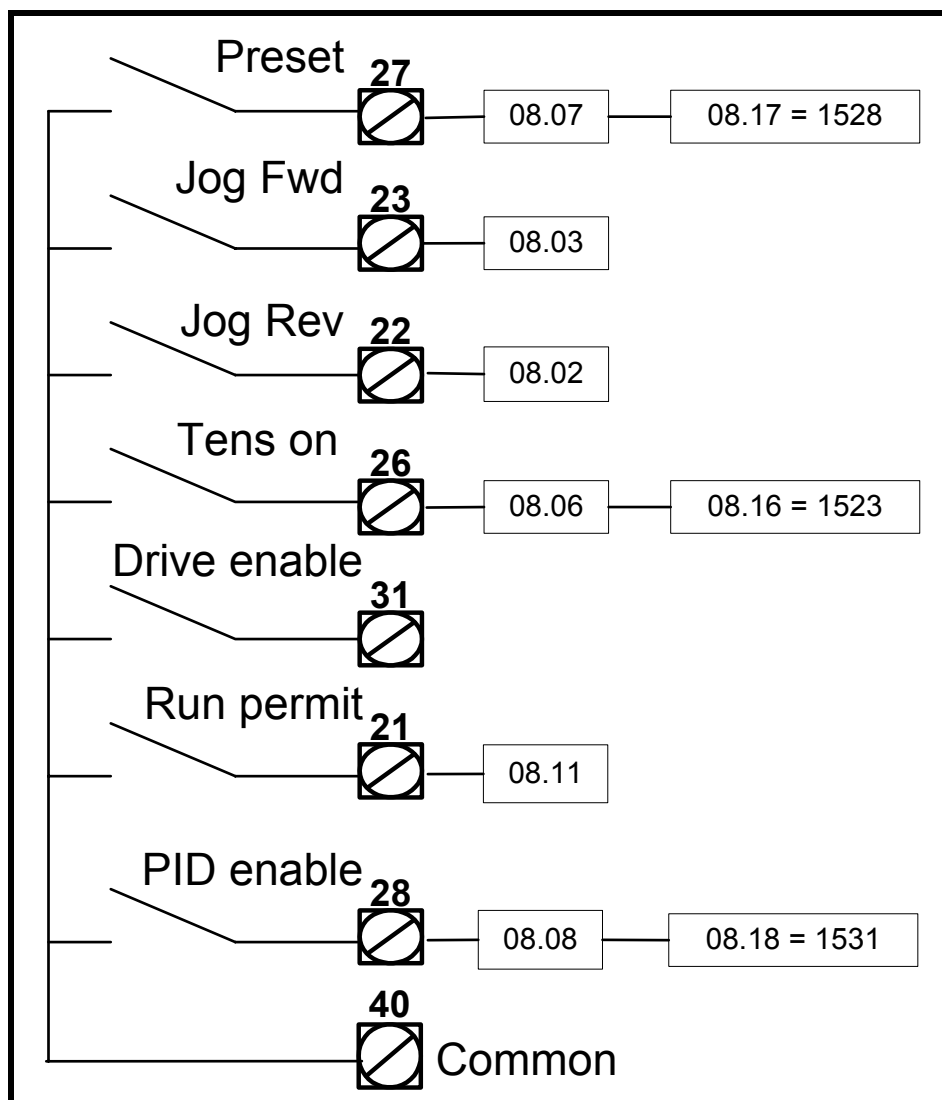

Quantum Speed controlled winder

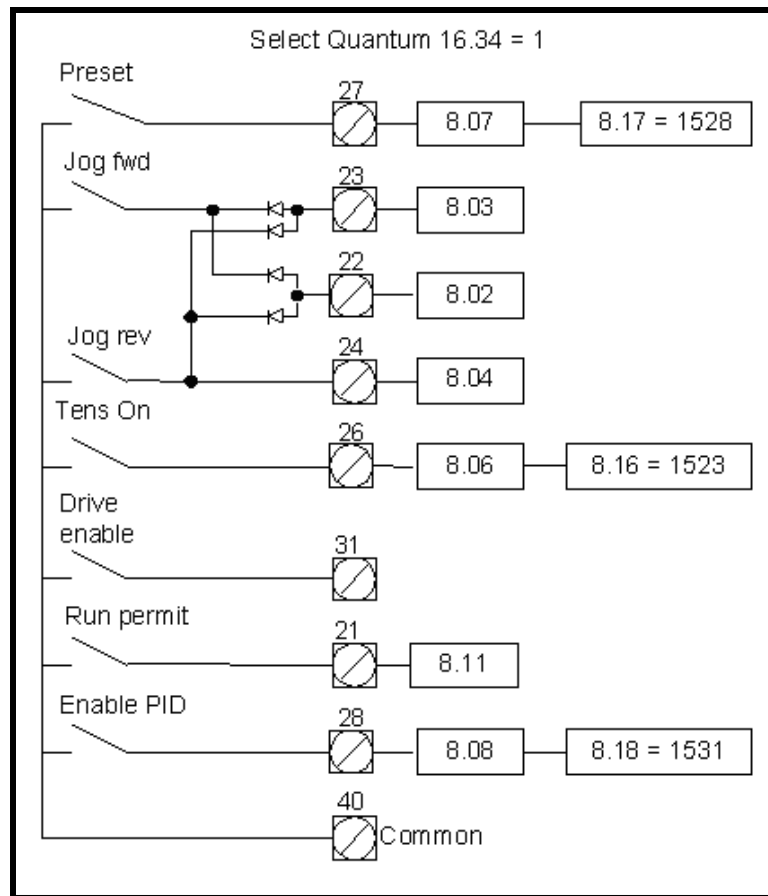

NOTE

The sequencing of the digital control inputs is important, the drive enable must be used simply to signal operation of the drive contactor with suitable pilot relay to ensure late make and early break. (N/O contactor pilot and contactor auxiliary contacts in series) connected to terminal 31.

The run permit should be enabled at all times when motion is required but must be enabled after the drive enable. Opening run permit terminal 21 will result in a current limit stop no matter what control inputs have been energised. The drive enable must remain enabled during the stopping period.

Inching and run to line speed functions can be achieved provided the drive enable and the run permit inputs are enabled.

The system logic will not return to a ready to inch or run state until the drive is at zero speed the drive enabled is on and the run permit has been removed.

On no account should terminals 21 and 31 be operated in parallel.

On speed controlled winders the operation of the centring routine ensures that the dancer is centred before the PID can take control, this avoids potential start up instability problems. It is therefore more convenient to set the PID enable 15.31 on via the drive key pad and save it. This will avoid unnecessary use of a digital I/O terminal.

3.6 Winder Drive Configurations

When Mentor is used for Winder Applications it should be operated only in closed loop mode.

Depending upon the powers required either a constant torque or constant power motor may be used. If a constant power motor is to be used then the Mentor field controller must be used.

In either case the motor must be fitted with a speed feedback device, this may be an incremental encoder or a DC tachogenerator.

If the winder is to follow a line speed reference provided by an encoder then this may be connected via PL4 on the MDA2B board.

4 Software Installation

There are two software files that must be installed within the Application module, these are as follows:

Application file	DcWinder.bin
System file	Runs the software and fieldbus interface.
e.g. M2NET.SYS	MD29 Application module only

The following parameters indicate the installed software version. '0' denotes no software file is installed.

Parameter	Description	Parameter Notation
11.16	System file version number	0 - 255
70.49	Application file version number	20801 = V02.08.01

To download the system and/or the application file to the application module the following items are required:

A standard one to one serial cable connected between the PC serial port and the RS232 port on the application module, (Connector C).

Control Techniques WindowsTM 'WinFlasher' software. This software is available on the CD, from any Control Techniques drive centre, or comes complete with 'Sypt' programming tool.

CTNet is the only high speed fieldbus interface supported by the MD29 when running this application software. Where is required the MD29AN application module is required.

Do not attempt to configure any CTNet cyclic or non cyclic links or download any SYPT based programme into the Winder MD29. This will result in the Winder.Bin file being overwritten. Links to other drives can be set up using easy mode connections or achieved using cyclic or non cyclic transmit commands from other drives on the network.

4.1 CTIU Software

When the CTIU110 is used the following software file is required to be downloaded to the unit.

- DC Winder metric.cmc or DC Winder imperial.cmc

Refer to section Software Version for more details.

The serial communication lead should be connected between the PC serial port and the RS232 port (9way D-type), on the CTIU.

5 Getting Started

5.1 Mentor

1. Refer to the Mentor Manual Getting Started section.
2. It may also be necessary to configure all or some of the related parameters that are listed in section Mentor Standard Parameters in the Mentor Manual.
3. The following parameters are directly controlled from the winder application software and will not require setting.

Parameter	Description	Software setting
01.06	Max Speed	-
01.07	Min Speed	0
01.10	Bipolar Reference Enable	1
01.13	Jog Select	0
01.14	Reference Selector	1
01.15	Reference Selector	0
01.18	Preset Speed Reference 1	-
02.02	Ramps Enable	-
03.14	Encoder scale factor	-
04.04	Torque Reference (Current limit)	-
04.09	Torque Offset	-
04.12	Torque mode selector (bit0)	-
04.13	Torque mode selector (bit1)	-
05.17	Software Inhibit	-
05.18	Stall logic	0
05.28	Hysterises	1
07.11	GP1 destination	0
07.12	GP2 destination	0
07.13	GP3 destination	0
07.14	GP4 destination	0
07.15	GP5 destination	0
14.04	Clock task time base	10

- Denotes variable setting dependant on mode and control state of winder software.

4. Ensure parameter 14.06 = 1. This enables the Winder software to auto-run on power up. If not set, perform the following procedure:
 - i. Set parameter 14.06 =1
 - ii. Set parameter 00.00 = 1 and press the reset. This will save all current settings of parameters in menus 1 to 16 to non-volatile memory.
5. Set parameter 14.16 = 1. This will reboot the application module and run installed application software.

5.2 Winder Control

1. If the drive is to be used as a torque winder then ensure that the correct current scaling burden resistor is fitted. The drive should be burdened for the maximum potential current, not 1.5 times motor full load current. Estimate the required current as follows
Max current (Rewind) = Tension current + Loss current + Accel current
Max current (Unwind) = Tension current - Loss current + Deccel current
2. Ensure that the Mentor is switched off and insert the Application Module.
3. Before attempting to power up the Mentor ensure that Enable input terminal 31 is open circuit.
4. If the software has not been installed then switch on and follow the instructions under Software Installation.
5. Ensure that the correct analog signals have been connected to the dedicated input terminals. There is no user configuration of analog input allocation. Select the programmable digital inputs to provide the required control functions, no user configuration options are allowed for the basic drive movement commands Inch Fwd / Rev, Run, Run permit and drive enable.

6. Calibration of Maximum Line Tension (16.10*16.11 or 70.00)
This parameter is used to scale an incoming analog tension reference signal to convert 0-10 volts, (or 0/4-20ma) into the correct engineering units. See section Mentor Analog I/O Allocation for details of analog connection. The maximum line tension must also be known when using an MMI or PLC to set the Tension set point digitally in engineering units.
If the data required to establish this information is not available the maximum line tension may be estimated from motor size.

$$\text{Max line tension} = \frac{\text{Motor base kW} \times 60000}{\text{Line Max MPM}} \text{Newtons}$$

7. Once the basic winder and drive system data has been entered the software calculates the required speed scaling to set the drive up. When using Encoder feedback the encoder PPR*10 should be entered in parameter 13.14. This is a wide parameter; the display does not show the least significant digit. When setting up directly via a serial communications link enter 10240 to represent 1024. When set via the keypad the Least Significant Digit is not displayed therefore the user must increment/decrement by 10 to see any change on the display.

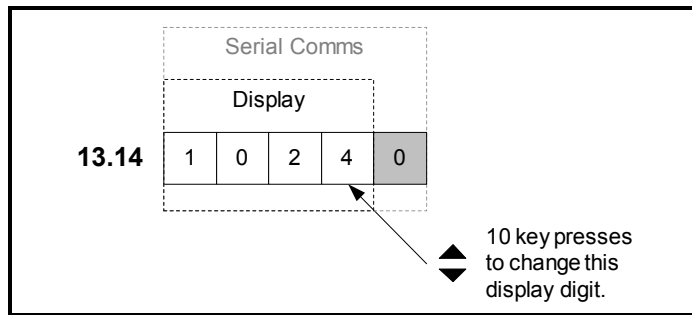

This information is used to set parameter 3.14 automatically by the software.
To assist setting up when a tachogenerator is used the maximum motor speed is displayed as follows:

15.50 RPM (Thousands and Hundreds)

15.51 RPM (Tens and Units)



The set up calculation will not be valid until the relevant data has been provided.

Data required includes:

Maximum Line speed (MPM)

Minimum roll diameter (mm)

Gear ratio

Encoder PPR when fitted

Lap count diameter calculation cannot be used with tacho feedback.

Maximum motor speed is also displayed as a single register in #71.08 for inspection via serial comms.

When using Tachogenerator feedback no automatic calibration is possible. The calculated maximum motor speed value #71.08 value is used to scale the virtual tacho feedback parameter #91.06 so that 0 - 16000 becomes equivalent to 0 - Maximum motor RPM. The user must ensure that the Tachogenerator feedback is suitably calibrated using the tacho voltage selection switch SW1 and the calibrating potentiometer RV1 on the MDA2 to adjust the tachogenerator feedback to ensure that #91.06 reads 16000 (#3.26 = 1000) when the motor is running at the speed displayed in #71.08 ie. The calculated Maximum motor RPM.

8. When a load cell is used for direct tension measurement then it should be calibrated. Procedures for calibration are usually provided in the load cell installation guide. Normally calibration procedures require the use of suitable weights and ropes.

Establish the correct material path over the rolls to determine how to thread the rope and apply the simulated tension loading. Remember that 1kilogram is approximately 10 Newtons.

9. User parameters have been assigned to all control functions ensuring maximum flexibility when configuring the system. Control for simpler systems may be provided using only the basic Mentor analog and digital I/O. More complex systems may require access to some or all of the control parameters using serial communications either directly from an operator terminal or from a PLC.

5.3 Operating Procedures

5.3.1 General Requirements

This software has been provided with the following set point and control inputs.

Process related

1. Line speed in analog or serial formats
Analog referencing allows the input to be provided by a 0 – 10 Volt signal or from an encoder (PL4)
A line speed reference must be provided. It should be sourced either from the master drive or from the last drive preceding the winder.
2. The line speed reference must be ramped, for more critical applications this should be an S Ramp.
3. Line acceleration rate in serial format.

Operator related

4. Set point values
 - Tension set point in analog or digital format
 - Taper set point in analog or digital format
 - Diameter set point in analog or digital format
5. Control inputs
 - Pay Out and Take Up jog commands (inch)
 - Tension On / Off command
 - Line Run command
 - Preset diameter command
 - Over/Under wind direction selection.
 - (Reverses the direction of rotation)

5.3.2 Direction of Rotation

In order to ensure correct operation of the software and achieve the required direction of rotation of the winder the following conventions must be followed.

All rotations are defined as looking on the front side of the winder (opposite side to the motor) and on the shaft end of the motor. If the installation employs either a direct drive or a belt drive both motor and winder directions of rotation will be identical.

Default is considered as clockwise when following a positive line speed reference signal transporting material from an Unwind to a Rewind with no gearbox reversals, as shown below.

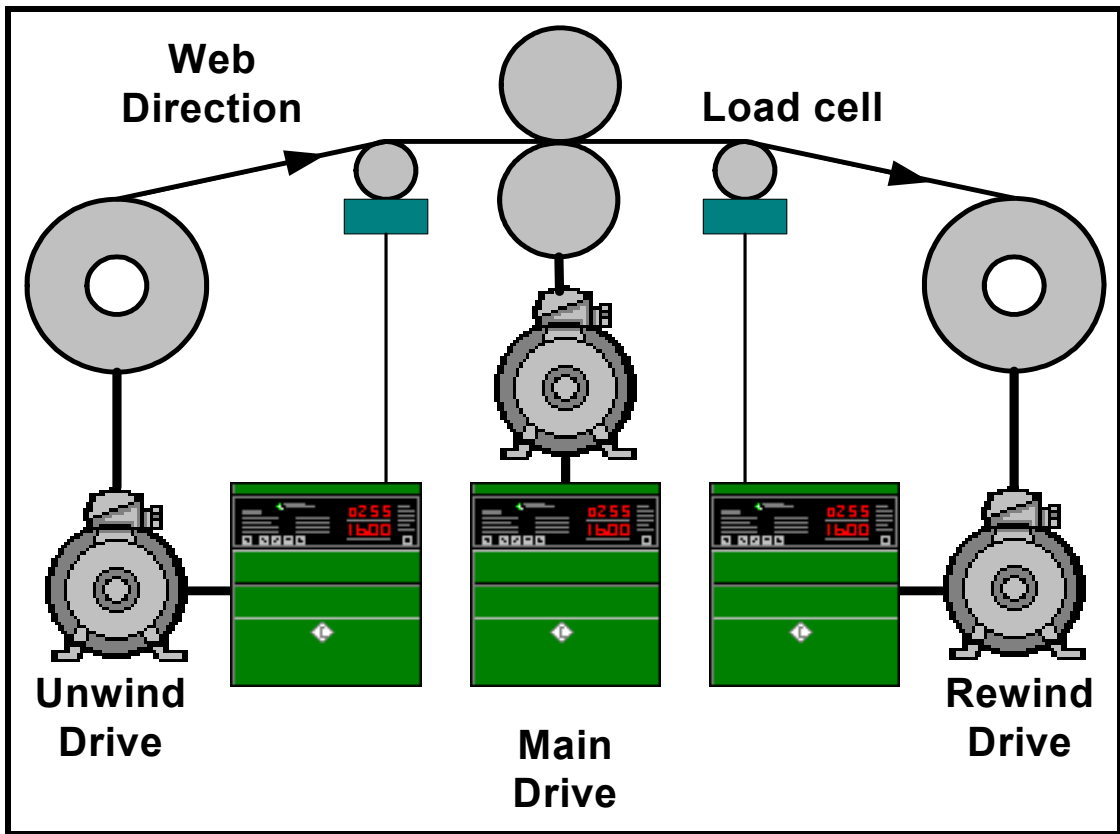

Set up to achieve the required directions of rotation is summarised in the tables below:
Positive line speed reference:

No reversal between motor and winder

Winder rotn	15.26	Motor rotn	16.25
CW	0	CW	0
CCW	1	CCW	1

Reversal between motor and winder due to gearbox

Winder rotn	15.26	Motor rotn	16.25
CW	1	CCW	1
CCW	0	CW	0

5. Once selected it should not normally be necessary to remove the tension on command whilst the material remains intact until the roll has been completely wound and the machine is at standstill. During odd stoppages for process reasons the tension will be reduced to the stalled tension value.
6. Should it be necessary to remove or part the material during the course of the process then the tension on command should be disabled.
7. If a web break occurs or some other emergency condition arises, removing the Tension on command will revert the drive to speed control and it will continue to run at the speed registered at that moment. If the run command is then removed the drive will ramp down to zero speed, (stopping mode is dependant on the setting of parameter 06.01, this is preferred to be set to ramped mode 'rp'). Arrangements should be provided to allow such a controlled stop to take place before the drive is inhibited.

State Engine for Winder Control

The following diagram indicates the allowable transitions in control state permissible when using the winder software.

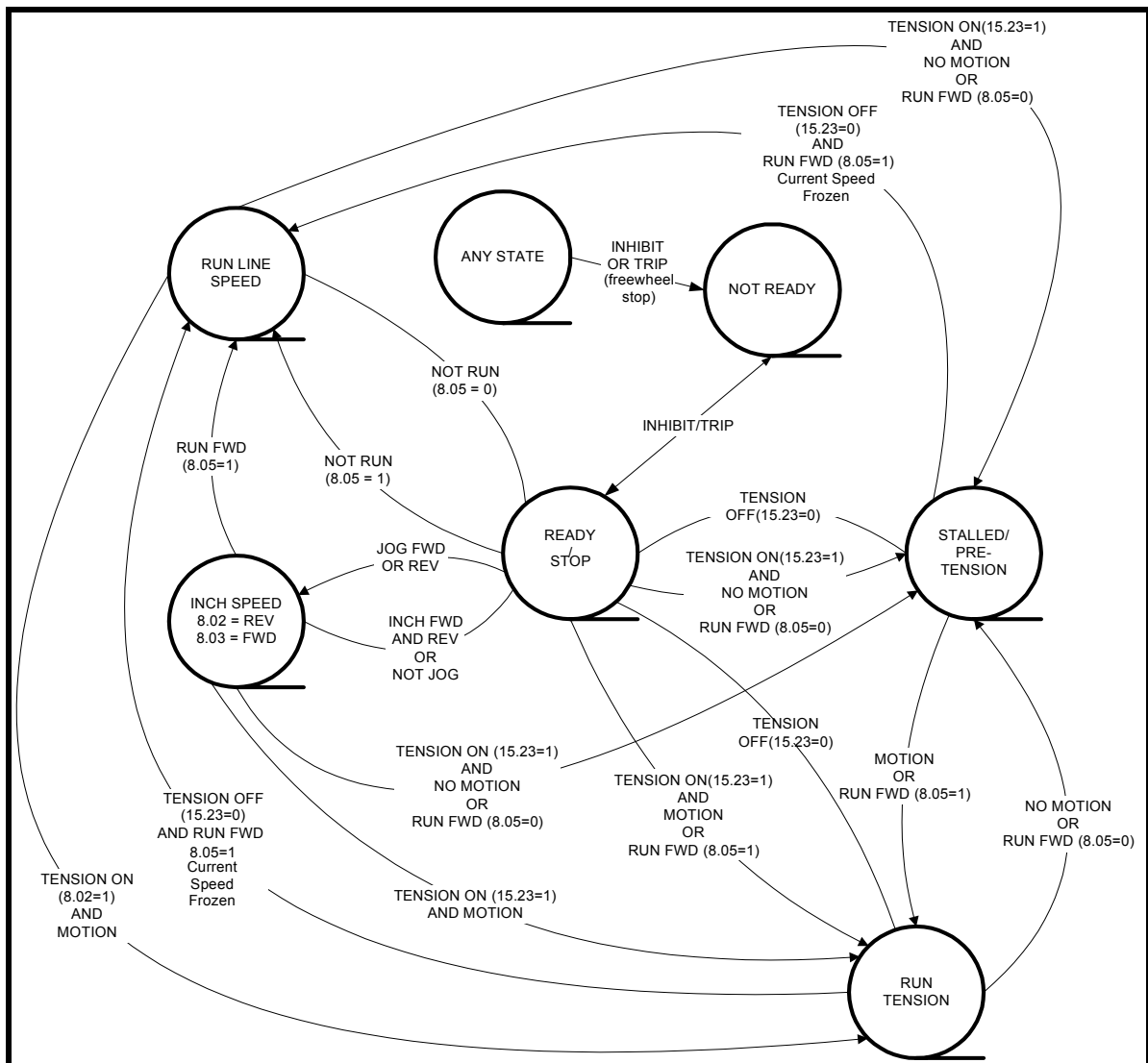

5.4 Basic I/O Configurations

These diagrams show the minimal configuration required for Winder operation. Any additional features may be provided either by the addition of an extended I/O module or via serial communication from a PLC or MMI.

5.4.1 Basic configuration for a Mentor Torque controlled winder

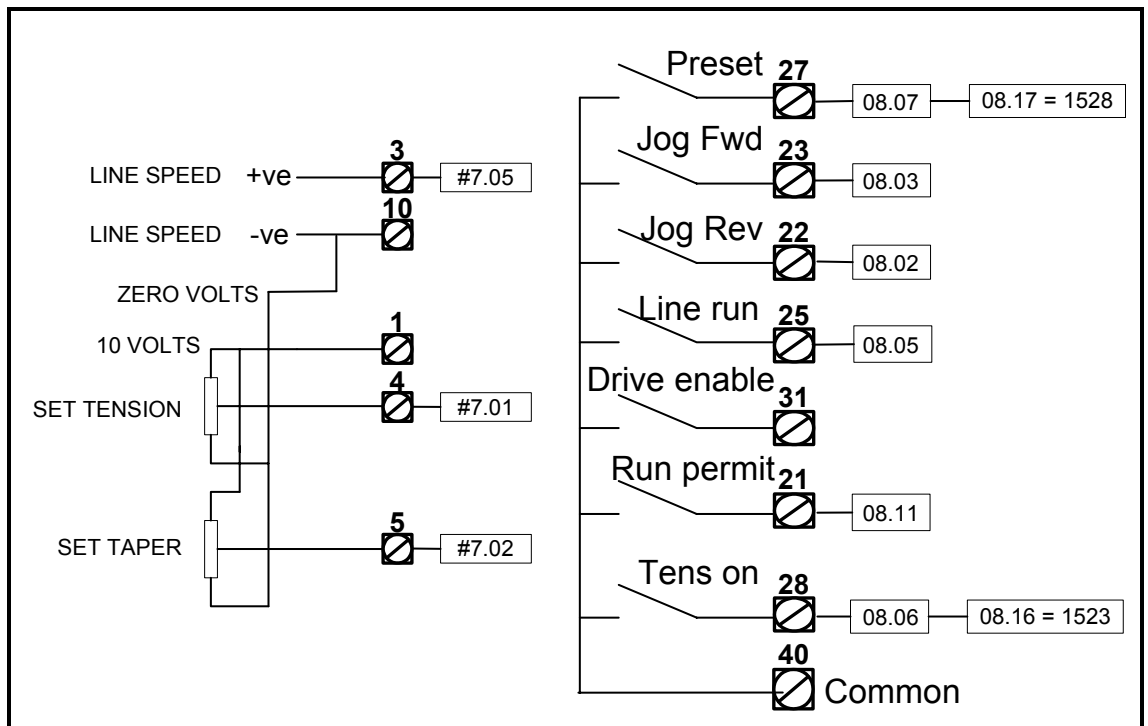

5.4.2 Basic configuration for a Quantum Torque controlled winder

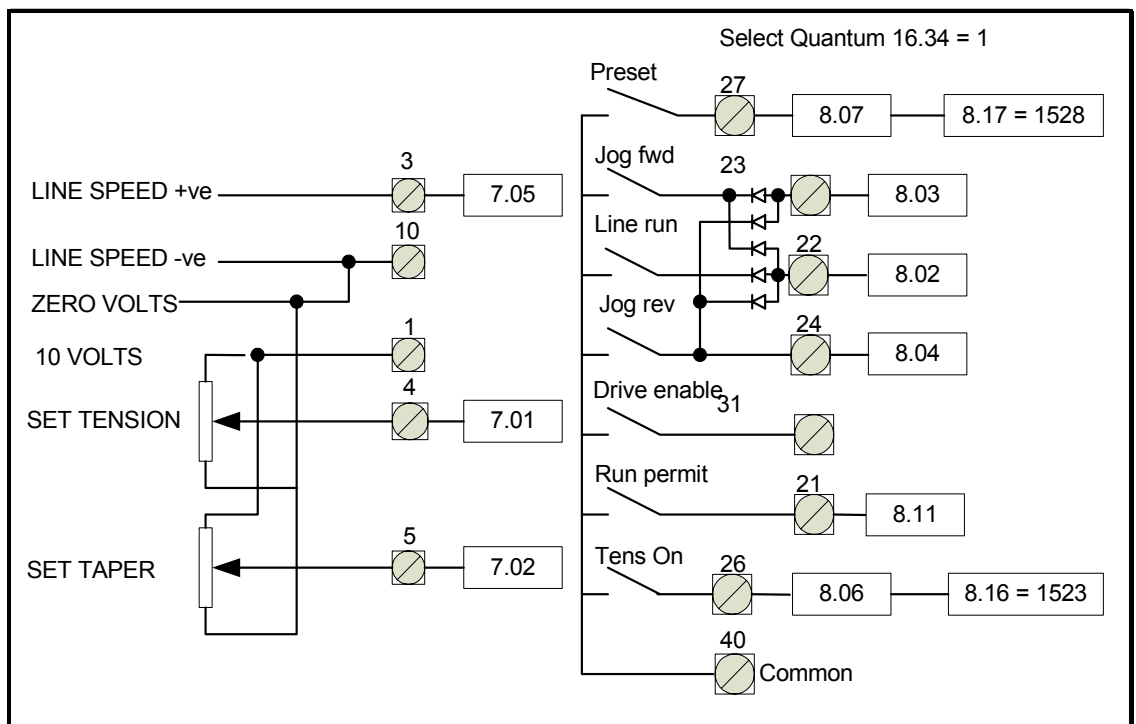

5.4.3 Basic Configuration for a Speed controlled winder

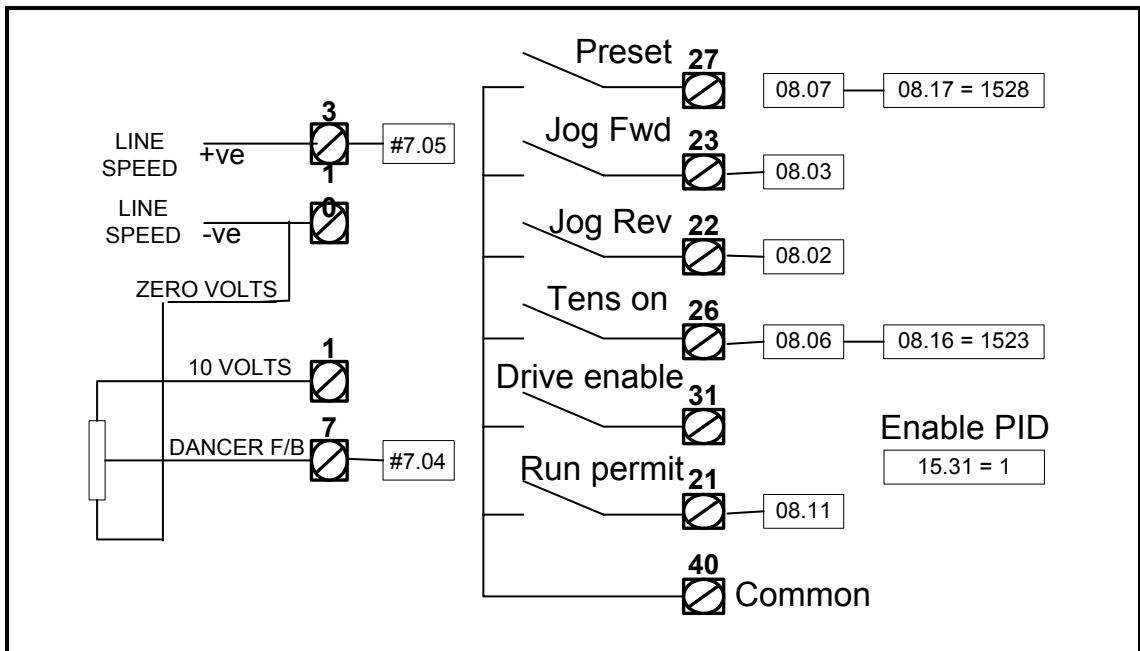

5.4.4 Basic Configuration for a Quantum Speed controlled winder

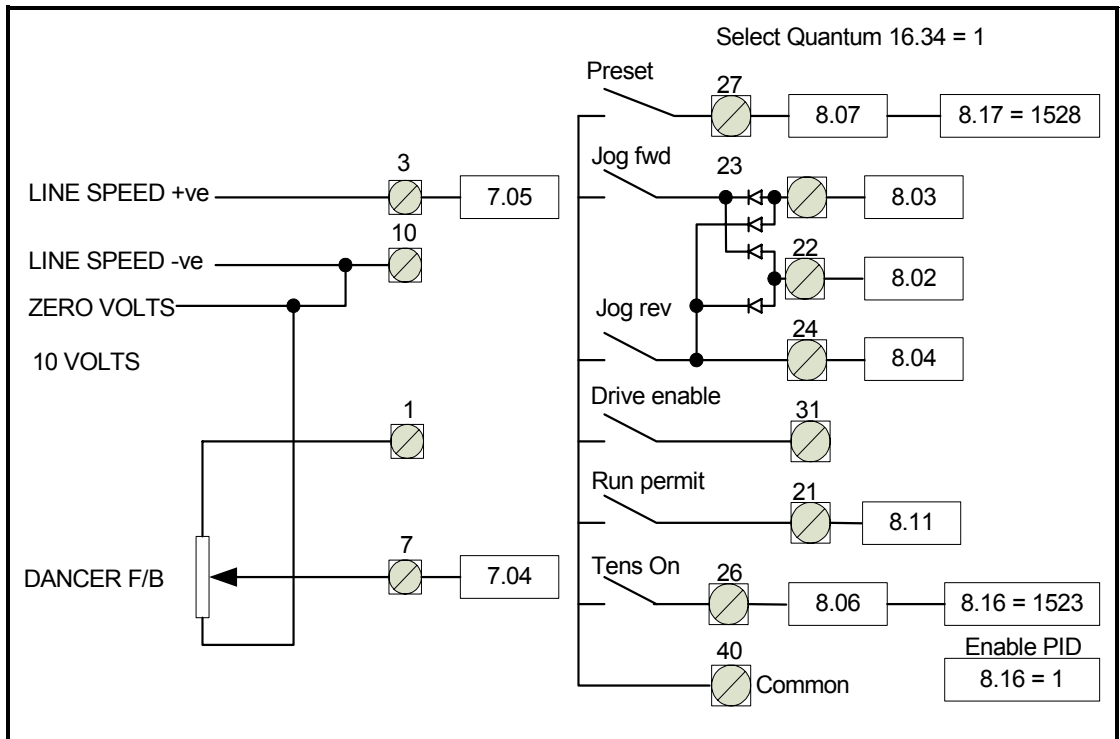

5.5 Configuration of Parameters

The flow chart below indicates the suggested sequence for parameter set up.

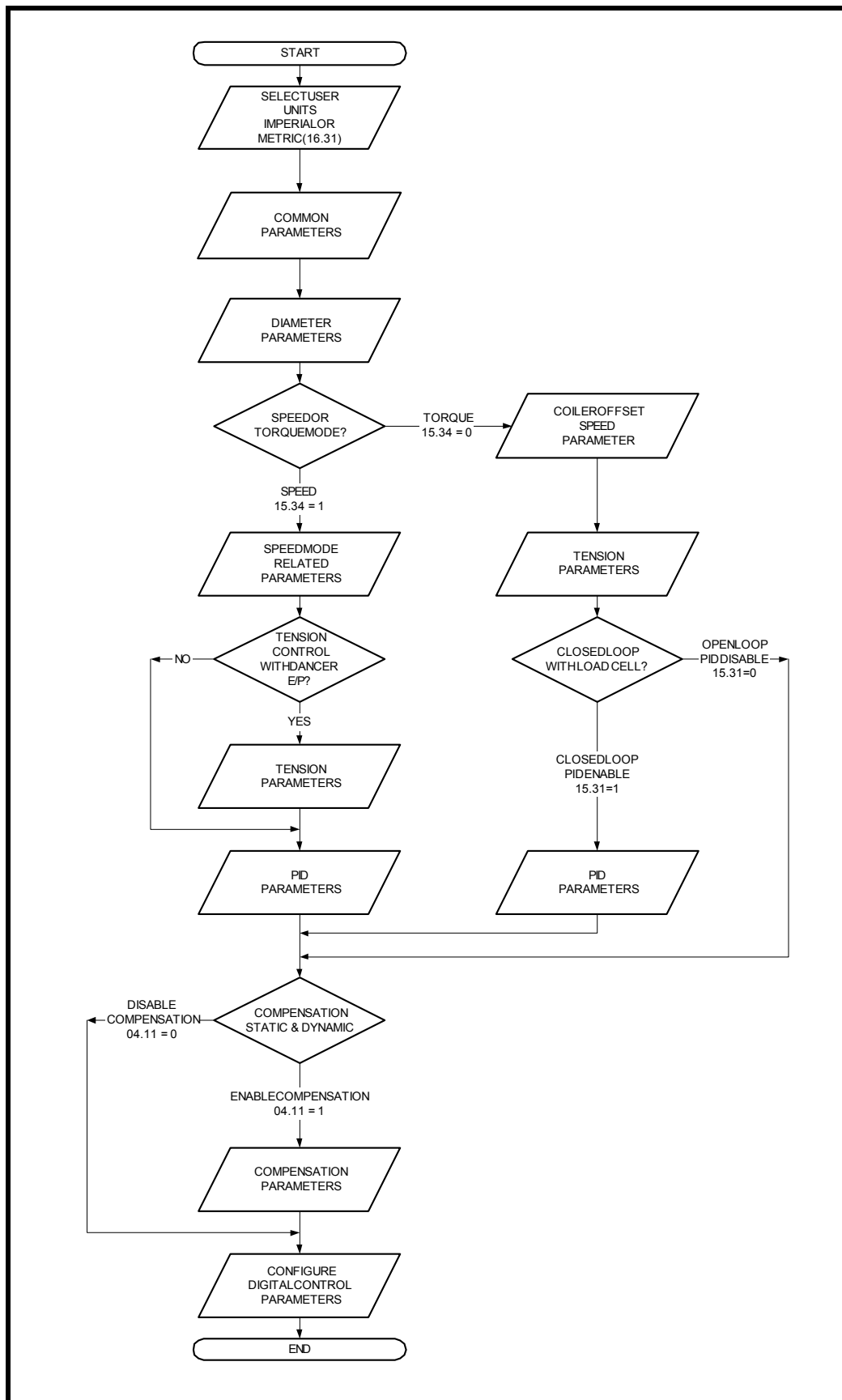

5.5.1 Alternative Parameter selection

To allow the majority of winder systems to be set up simply, most of the more frequently used parameters have been assigned to Mentor parameters accessible via the key pad and display. However on some occasions the range of data to be input or the complication of using dual parameter entry (eg. when using MMI input) makes this impossible. A set of alternative parameters have therefore been allocated together with their respective selection bits, the additional input parameters are located in Menu 70 and a set of wider range display parameters have been created in Menu 71.

Alternative basic dimensional parameters 70.00 – 70.07 & 70.35 are selected as a group when 70.10 = 1, individual digital input set point parameters are enabled by their individual selection bits and a set of alternative PID set up parameters 70.14 – 70.16 is selected when 70.13 = 1.

The diagrams over-leaf provide a quick guide to set and set up selection.

The diagrams are intended as a quick guide for keypad set up. It shows all the application parameters accessible via the keypad and any associated Menu 70 alternatives, including the method of selection. For more comprehensive information see the overview diagrams and the parameter listings.

Infrequently used parameters for more specialised applications and parameters, which will frequently remain at their default settings are located in menu 70.

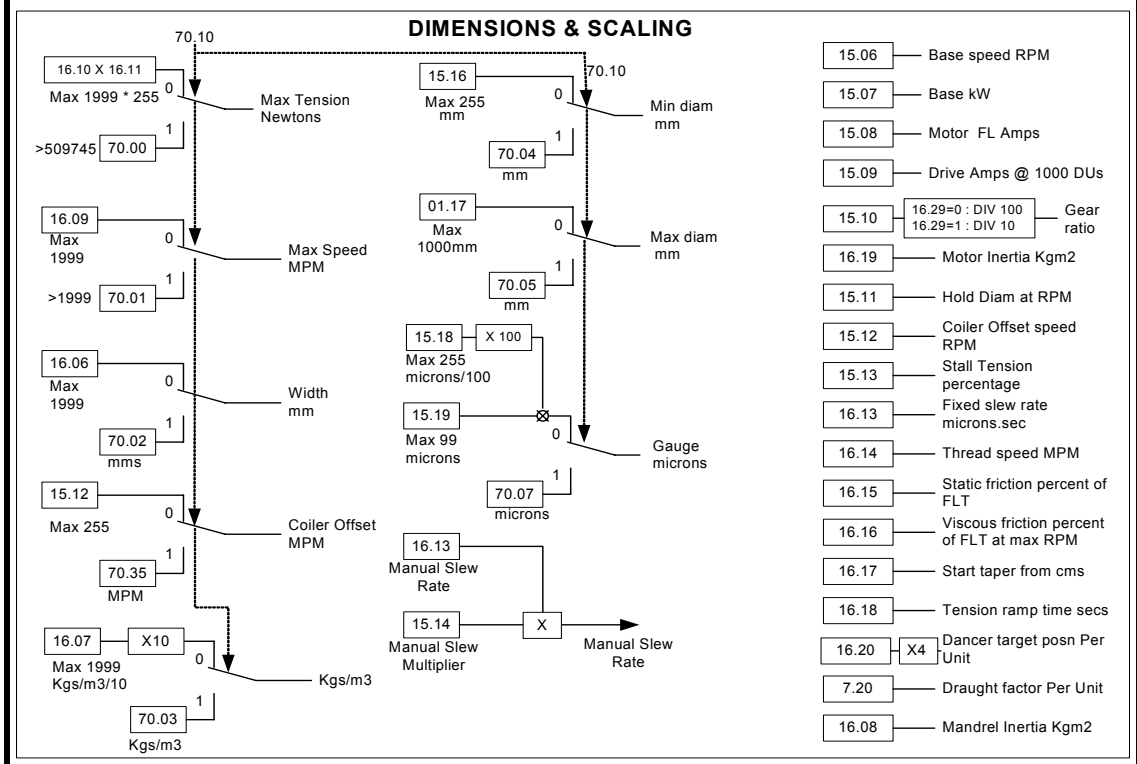
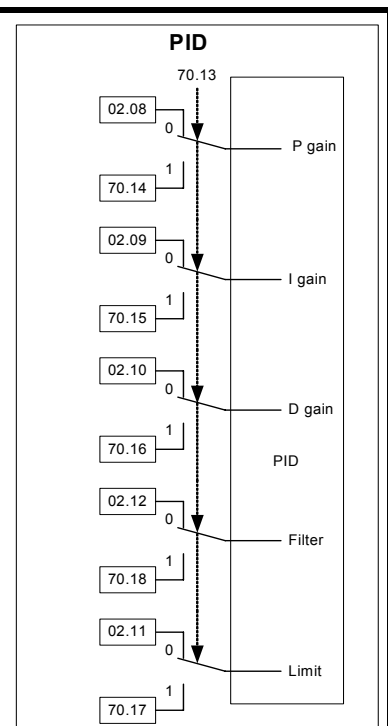
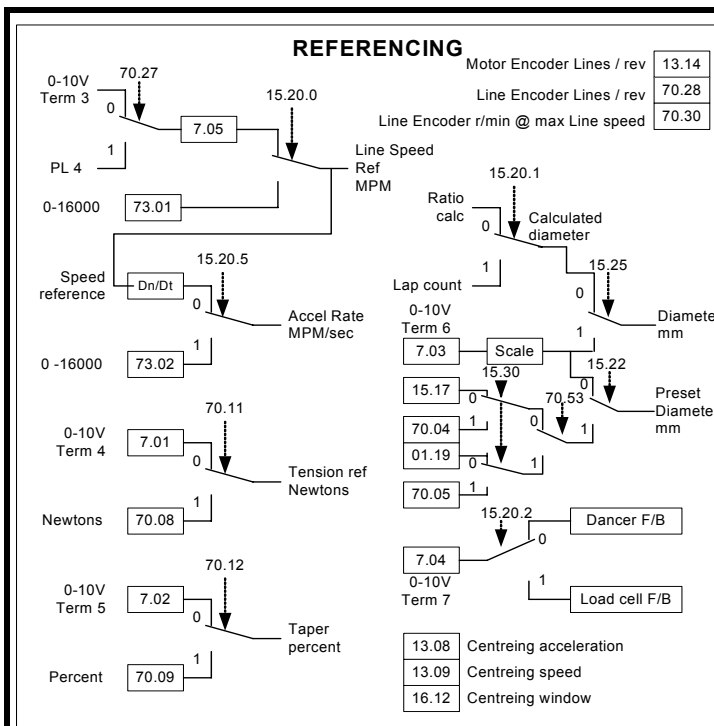

- 15.06 — Base speed RPM
- 15.07 — Base kW
- 15.08 — Motor FL Amps
- 15.09 — Drive Amps @ 1000 DUs
- 15.10 — Gear ratio
16.29=0 : DIV 100
16.29=1 : DIV 10
- 16.19 — Motor Inertia Kgm2
- 15.11 — Hold Diam at RPM
- 15.12 — Coiler Offset speed RPM
- 15.13 — Stall Tension percentage
- 16.13 — Fixed slew rate microns.sec
- 16.14 — Thread speed MPM
- 16.15 — Static friction percent of FLT
- 16.16 — Viscous friction percent of FLT at max RPM
- 16.17 — Start taper from cms
- 16.18 — Tension ramp time secs
- 16.20 — Dancer target posn Per Unit
7.20 — Draught factor Per Unit
- 16.08 — Mandrel Inertia Kgm2

5.5.2 Classified Parameter Listing

The following parameters list is grouped to match the approach suggested in the diagram above.

Common Configuration Parameters

No.	Description	Units	Comments
16.31	Select the form of engineering units for set up data	Bit	0 – Metric 1 – US Standard LOCKED WHILE RUNNING
15.26	Select Over or Under winding direction	Bit	0 – Over wind 1 – Under wind Reverses the direction of rotation. Set this bit if the web entry or exit from the coil needs to be changed, or the direction is reversed due the gearbox or orientation of the motor. LOCKED WHILE RUNNING
15.29	Select to operate as an Unwind	Bit	Winder control for the forward line speed direction. 0 = Rewind. 1 = Unwind. LOCKED WHILE RUNNING
16.09 70.01	Maximum line speed	m/min (ft/min)	Set to the maximum line speed. For variable maximum line speed for different product this could be updated remotely via serial comms. 70.10 = 1 to select 70s
07.20	Line Speed Slip factor	0.001%	Set the slip factor to compensate for any difference between nip speed and line material speed at the master drive. e.g. 1000 = 1.000
15.20.0	Select serial input for Line Speed reference	Bit	0 – Analog Line speed reference. Refer also to parameter 07.05. The acceleration is derived from this signal internally by the software. 1 – Line speed and acceleration are derived via serial communications to parameter 73.01 & 73.02 respectively.
07.05	Line Speed reference Analog format	PU	Source an analog input to this parameter, preferably analog 1. Refer to section 3.4.4. Ensure it is positive with required forward line direction.
15.10	Gear ratio	0.01 (16.29=0) 0.1 (16.29=1)	Enter gear ratio e.g. 250 = 2.5. Set to 100 when no gearbox is used. Where larger gear ratios are required set parameter 16.29.
16.29	Gear Ratio x10 multiplier	Bit	15.10 range 0 = 100-1999 (1.00 - 19.99) 1 = 100-1999 (1.0 - 199.9)
15.18 15.19	Material gauge	µm (0.001ins)	Enter Material gauge, this is used for lap count and Inertia compensation calculation.
15.06	Motor base Speed	r/min	Motor nameplate speed at mains frequency.
15.07	Motor base Power	1kW (1hp)	Motor Nameplate Power at base speed.
15.08	Motor current	Amps	Motor Nameplate Current at base speed.
15.09	Drive current	Amps	Current equivalent to 1000DUS
01.05	Motor voltage	Volts	Motor Nameplate Voltage at base speed.
15.14	Manual slew multiplier	Multiplier	Allows an increase to the manual slew rate 16.13
15.15	Not Allocated		
70.06	Not Allocated		

70.10	Select Set Up Data from Menu 70 sources	Bit	0 – Mentor display parameters are used. 1 – Menu 70 high resolution parameters are used.
16.14	Thread/Inch speed	m/min (ft/min)	Pay Out and Take Up, Inch speed reference.
13.14	Motor Encoder PPRx10	-	Set to the motor encoder pulses per revolution.
15.20.6	Watch dog enable	Bit	Enable when winder is controlled remotely via serial communication. Refer to parameter descriptions for more details.
16.24	Enable Speed Boost	Bit	Adds the value in 70.26 to the line speed reference
70.20	Watchdog Clock Time	0.01s	
70.21	Watchdog trip delay	0.1s	
70.26	Speed Boost value	MPM	Amount by which the line speed ref will be increased when 16.24 = 1
70.27	Select encoder as line speed reference source	Bit	Allows the winder to follow an up stream encoder
70.28	Line encoder PPR	PPR	Set to the line encoder pulse per revolution, when selected.
70.29	Time base for line encoder speed measurement	0.01s	
70.30	Line encoder RPM at maximum line speed	RPM	Scales encoder frequency to maximum line speed
15.20.7	Select Back EMF mode	Bit	This enables the field current profiling function 70.80-70.89. Diameter, 71.80-71.89 field percentage demand.
Status & Indication Parameters			
16.04	Final Speed Reference	m/min (ft/min)	Winder final line speed reference
71.04	Final Speed Reference	m/min (ft/min)	Winder final line speed reference High Resolution
15.04	Line Speed	m/min (ft/min)	Line speed from master drive
71.03	Line Speed	m/min (ft/min)	Line speed from master drive High Resolution
15.05	Winder Speed	r/min	Actual Winder speed
15.50 15.51	Max Motor Speed	r/min	15.50 indicate the 1000&100's or r/min 15.51 indicate the 10's & units of r/min. Used for tacho calibration.
71.08	Max Motor Speed	r/min	Equivalent high resolution parameter
16.38 16.39	Actual Motor Speed	r/min	16.38 indicate the 1000&100's or r/min 16.39 indicate the 10's & units of r/min.
71.05	Actual Motor Speed	r/min	Actual Motor speed
15.36	Web break error flag	Bit	0 – OK 1 – Web break (Latched & Reset when drive is stopped)
16.35	Tensioned flag	Bit	1 when dancer centring completed
16.36	Watch dog trip	Bit	0 – OK 1 – Trip
16.30	Speed reference polarity	Bit	0 – Positive (Forward line direction) 1 – Negative (Reverse line direction)

Diameter Parameters

No.	Description	Units	Comments
15.16 70.04	Minimum diameter	mm (0.1ins)	Core diameter. 70.10 = 1 to select 70s
01.17 70.05	Maximum diameter	mm (0.1ins)	Coil max diameter 70.10 = 1 to select 70s
15.25	Select direct measurement of diameter via analog input	Bit	0 – Diameter is calculated internally 1 – Direct Analog measurement of diameter. Refer also to parameter 07.03.
07.03	Preset Diameter Analog format	PU	Source an analog input to this parameter. Refer to section 3.4.4. Ensure the signal is positive and increases with diameter.
70.57	Analog diameter signal min. value	PU	Set to the value in 07.03 for minimum diameter.
70.58	Analog diameter signal min. value	PU	Set to the value in 07.03 for maximum diameter.
15.22	Select Diameter Set Point from parameter 15.17/ 01.19	Bit	Preset diameter reference. 0 – From analog signal derived via 07.03. 1 – From parameter 15.17/01.19.
15.30	Select second diameter preset parameter 01.19	Bit	15.30 = 0 Preset from 15.17 15.30 = 1 Preset from 01.19 70.53 = 1 selects 70.51 & 70.52
15.17 70.51	Preset diameter value 1	mm (0.1ins)	Preset diameter when 15.22 = 1 & 15.30 = 0. This preset diameter is only entered when tension is off, 15.23 = 0, and parameter #15.28 = 1. Refer to current diameter parameter 15.01 when #15.28 =1 has been performed Replaced by 70.51 when 70.53 =1
01.19 70.52	Preset diameter value 2	mm (0.1ins)	Preset diameter when 15.22 = 1 & 15.30 = 1. This preset diameter is only entered when tension is off, 15.23 = 0, and parameter #15.28 = 1. Refer to current diameter parameter 15.01 when #15.28 =1 has been performed Replaced by 70.52 when 70.53 =1
70.53	Select Alternative Preset	Bit	0 = Uses 15.17 or 01.19 parameters. 1 = Uses 70.51 or 70.52 parameters.
15.28	Preset diameter command bit	Bit	Set to enter preset diameter, refer to 15.17(70.51) and 01.19(70.52). The bit will auto reset to 0.
15.20.1	Diameter Calculation Mode	Bit	0 – Ratio mode ((m/min) / (r/min)) 1 – Lap count mode. Refer to parameter 16.27
16.25	LAP Reverse direction of diameter change under Lap or Traverse	Bit	Reverses the direction of the lap counter. Use to correct diameter change direction when reversal occurs due to winder configuration. When the unwind, (15.29) & under/over lap, (15.26) parameters have been correctly configured, set lap count reversal bit if the diameter is inc/dec in the wrong direction.
16.27	LAP Select Traverse mode for diameter calculation	Bit	Traverse winding 0 – Diameter Lap count determined by the number of winder revolutions multiplied by 2xGauge. 1 – Diameter Lap count is incremented by 2xGauge every reversal of the traverse axis. Refer to parameter 16.26
16.26	LAP Signal Traverse reversal	Bit	Source a digital input to this parameter for the traverse reversal pulse signal.
16.33	RATIO Hold diameter command bit	Bit	Set this bit to freeze the current diameter value. This can be sourced from a digital input.

16.34	Select Quantum	Bit	Configures internal logic to suit Quantum digital I/O
15.11	RATIO Diameter Hold function speed threshold	r/min	Set this to the low speed threshold where the speed indication becomes too erratic for the speed calculation.
15.20.4	RATIO Select fixed diameter slew limit	Bit	0 –Slew rate determined from material gauge and the winder speed. 1- Fixed slew from parameter 16.13. Diameter slew rate clamps the rate of change out put by the diameter calculator, effectively filtering transient excursions.
16.13	RATIO Fixed value for Diameter slew rate	$\mu\text{m/s}$ (0.001ins/s)	If 15.20.4 =1 then set the slew accordingly.
70.36	Slew Rate Hold Threshold	$\mu\text{m/s}$ (0.001ins/s)	If the slew rate falls below this level the diameter hold function will become active. Application specific.
70.22	Winder Speed Sample Time	ms	Set this parameter to ensure a smooth indication of winder speed for the ratio diameter calculation. Too short a sample time will produce erratic diameter results & too slow will effect the performance of the winder.
70.33	Acquire multiplier	-	Set to provide the required increase in slew rate for the application.
70.34	Enable acquire on start	Bit	Applies the acquire multiplier (70.33) on start up.
15.24	Enable acquire	Bit	Applies the acquire multiplier (70.33) when set
15.27	Enable Slack Web detection	Bit	Set to hold the diameter calculation, when a slack web is detected.
70.32	Slack Web detection threshold	0.1%	Sets the sensitivity for detecting a slack web.
Status & Indication Parameters			
15.01	Current radius display	mm (0.1ins)	Current actual radius
71.01	Current diameter display	mm (0.1ins)	Current actual diameter
15.02	Preset radius value	mm (0.1ins)	Current cache preset radius value
71.02	Preset diameter value	mm (0.1ins)	Current cache preset diameter value
15.35	Diameter calculation error flag	Bit	0 – OK 1 - Error
15.40	Diameter Hold Flag	Bit	Indicates diameter Hold active.

Speed Mode Parameters

No.	Description	Units	Comments
15.34	Speed Mode select	Bit	Set for Speed controlled winder 0 – Torque mode 1 – Speed mode
15.20.2	Select Dancer or Load cell operation	Bit	Set for the required feedback 0 – Dancer 1 – Load cell
07.04	Load cell/Dancer feedback	PU	Source an analog input to this parameter. Refer to section 3.4.4. Ensure the signal is positive and increases with dancer position.
16.20	Dancer Position Set point	PU	Manually set the dancer arm to the required position. Take reading from dancer feedback parameter 07.04 and set this parameter to the same value.
16.12	Centring Window	PU	This will determine the window of acceptance, for the completion on the centring routine. If set too low with a high centring speed (13.09) or low accelerations (13.08), could cause oscillations as the winder cannot stop within the set window.
13.09	Centring Speed	m/min (ft/min)	Set centring speed, refer to 16.12 for more details
13.08	Centring Acceleration	cm/min/s (ins/min/s)	Set centring acceleration rate, refer to 16.12 for more details
16.21	Select Torque memory mode	Bit	0 = Normal speed mode 1 = Fix torque at previous average value
70.40	Coupling Speed	r/min	This is the set speed when coupling is enabled (15.37=1). Set in winder r/min, for alignment of coupling.
70.41	Coupling Current limit	0.1%	This is the set current limit when coupling is enabled (15.37=1).
Status & Indication Parameters			
15.03	Required tension as per unit value use for E/P output	PU	Source to analog output for Dancer E/P tension setpoint.
16.35	Web Tensioned Flag	Bit	0 – Not tensioned 1 – Tensioned, centring routine complete

Torque Mode Parameters

No.	Description	Units	Comments
15.34	Speed Mode select	Bit	Set to 0 for torque controlled winder 0 – Torque mode 1 – Speed mode
15.12 70.35	Offset speed	m/min (ft/min)	Set this offset to ensure the drive remains in torque control and tension is maintained at all speeds whether it is unwinding or rewinding. 70.00 selected when 70.10 = 1
Status & Indication Parameters			
71.06	Actual Tension	N (lbf)	Actual winder Tension
71.07	Tension Set point	N (lbf)	Winder Tension set point, derived after the taper has been applied and tension ramped.
16.01	Tension torque component	Nm (lb.ft)	Related to the real tension, without compensation.
16.02	Compensation torque component	Nm (lb.ft)	Related to the friction & Inertia compensation.

Tension Parameters

No.	Description	Units	Comments
16.10 * 16.11 70.00	Maximum Tension Product of 16.10 & 16.11	N (lbf)	Enter maximum tension range, used for internal scaling. This should be matched to the load cell or the E/P range of the dancer and the size of the motor. 70.00 selected when 70.10 = 1
15.20.0	Select serial input for Line Speed reference	Bit	0 – Analog Line speed reference. <i>Tension feedback derived from analog input terminal 7. 10bit resolution. (voltage signal only).</i> 1 – Line speed and acceleration are derived via serial communications to parameter <i>Tension feedback derived from analog input terminal 3. 12bit resolution. (voltage or current signals).</i>
15.13	Percentage of Tension applied as Stall Tension	%	Set the required percentage tension at standstill. This percentage could be of set point or Max Tension depending on setting of parameter 15.20.3.
15.20.3	Set stall tension as percentage of Maximum tension	Bit	Stall percentage range of 0 – Set point 1 – Maximum Tension 16.10 (or 70.00).
16.32	Select condition which switches from Stall to Run tension	Bit	Select run tension using 0 – Run input true 1 – Line speed reference above zero
70.11	Select Tension Set Point from parameter 70.08	Bit	Tension Reference selection 0 – analog parameter 07.01 1 – Digital parameter 70.08
07.01	Tension reference Analog format	PU	Analog input for tension ref. Refer to section 3.4.4. Ensure the signal is positive and increases with Tension demand.
70.08	Tension Set point (Digital)	N (lbf)	Tension reference when 70.11=1. Entered in Newtons
16.18	Tension reference ramp time	s	Enter ramp time dependant on the application.
16.28	Hyperbolic Taper select	Bit	Taper profile type selection 0 – Linear 1 - Hyperbolic
70.12	Select Taper set Point from parameter 70.09	Bit	Taper set point selection 0 – analog parameter 07.02 1 – digital parameter 70.12
07.02	Taper reference Analog format	PU	Source an analog input to this parameter. Refer to section 3.4.4. Ensure the signal is positive and increases with Taper percentage.
70.09	Taper Set point (Digital)	%	Enter Taper set point at maximum diameter when 70.12=1.
16.17	Diameter at which Taper Tension will start	mm (0.1ins)	Set the diameter threshold when the taper tension profile will start.
16.22	Enable Lay On Roll tension boost	Bit	Increases the tension by the percentage of max tension in 70.25
16.23	Enable Indexing tension boost	Bit	Increases the tension by the percentage or running tension in 70.24
70.24	Index tension boost value as a percentage of operating tension	0 –1000 = 0 – 100%	Sets the extra torque applied to compensate for turret indexing
70.25	Lay On boost value as a percentage of maximum tension	0 – 1000 = 0 – 100%	Sets the extra torque applied to compensate for the effect of the Lay On roll during roll changes
Status & Indication Parameters			

NOTE

Tension set point is used in SPEED mode, for setting the required Dancer Tension set point via an E/P analog signal.

PID Parameters

No.	Description	Units	Comments
07.04	Load cell / Dancer feedback	PU	Analog input for tension f/b. Refer to section 3.4.4. Ensure the signal is positive and increases with Tension or position.
02.08 70.14	PID control P gain	0.001Kp	Proportion Gain. For an error of 1, and a Proportional gain of 1000, the output of the P term will be 1. 70.13 = 1 select 70.14
02.09 70.15	PID control I gain	0.1Ki	Integral gain For a constant error of 1, and an Integral gain of 10, the output of the I term will reach 1 after 1 second. 70.13 = 1 select 70.15
02.10 70.16	PID D Gain	0.1Kd	Derivative Gain For a constant rate of change of error of 1 unit per second and a differential gain of 10, the output of the D term will be 1. 70.13 = 1 select 70.16
02.12	D Filter	-	Derivative 2 nd order filter. This will filter fast rates of rise of the derivative term.
02.11	Limit on PID output	Tension-% Speed-cm/min (0.01ft/min)	This sets the amount of action range from the PID to the main feed forward reference. Speed – Trim to the main speed reference. Torque – ratio of the main tension reference
15.31	PID Enable	Bit	0 – Disable PID 1 – Enable PID. Initiates centring and enables PID when centring completed in Speed Mode. Enables PID directly in Torque Mode.
15.32	PID Hold integral	Bit	0 – Normal integration 1- PID Hold integrator
15.33	PID Reset integral	Bit	0 – Normal integration 1- Reset Integrator.
Status & Indication Parameters			
16.03	PID error	Torque - PU Speed - pos	Error = set point - feedback
15.39	PID Output	Torque – 0.1% Speed – cm/min (0.01ft/min)	PID output result.
70.37	Start value for PID gain profiler	Percent of Max MPM	Sets the speed above which the PID gain in Speed Mode will be increased in proportion to line speed
70.38	Reset length count in 70.19	Bit	

Compensation Parameters

No.	Description	Units	Comments
04.11	Select compensation torque	Bit	Set if friction or inertia compensation is required.
16.06 70.02	Material width	mm (0.1ins)	Enter material web width. 70.10 = 1 selects 70.02
16.07 70.03	Material density	kgms/m ³ (lb/ft ³)	Enter the density of material 70.10 = 1 selects 70.03
16.08	Mandrel inertia	kgm ² (lb.ft ²)	Enter mandrel inertia
16.19	Motor inertia	kgm ² (lb.ft ²)	Enter motor inertia, this can be obtained from the motor nameplate or from the manufacturer. If inertia compensation is not required set this parameter and 16.08 to 0.
16.15	Friction loss	0.1%	Enter frictional loss. This can be deduced by running the winder at low speed, with no material, and reading torque demand parameter 04.01. e.g. 10 = 1.0% See 70.70 71.70 for details on loss profiling
16.16	Viscous loss	0.1%	Enter the maximum viscous loss. This can be deduced by running the winder at maximum speed, with no material, and reading torque demand parameter 04.01 or 70.54 (corrected for flux compensation). e.g. 10 = 0.1%. Allowing for the effect of 16.15. See 70.70 71.70 for details on loss profiling
15.21	Select loss profiling from look up table	Bit	Selects loss profile from speed / torque look up table 70.70/ 71.70 thru 70.79/71.79
15.20.5	Select acceleration signal	Bit	The rate of acceleration is used in calculating the acceleration torque. 0 – Acceleration determined internally from the analog line speed signal derived to parameter 15.04 or the serial line speed derived to 73.01 1 – Acceleration provided from an external source usually the main drive via parameter #73.02.
70.23	Line speed signal differentiator sample time	10ms	If the acceleration is to be derived from differentiating the line speed signal this sets the differentiator sample time. A Noisy acceleration signal maybe experienced if set too low. 1 = 10mS
Status & Indication Parameters			
16.02	Compensation torque	Nm (lb.ft)	Derived resultant compensation torque, sum of inertia and loss compensation torques.
16.05	Acceleration rate	m/min/s (ft/min/s)	Line acceleration, derived from line speed signal or read directly from parameter 73.02.
15.38	Indication of Torque demand	PU	Use this to set the loss profiler value/s.
70.55	Loss Profiler Pointer	-	Indicate current position in profile loss table.

Digital Control Parameters

These parameters are used to control the function of the winder software and will be controlled either by digital I/O or via serial communications.

No.	Description	Units	Comments
15.23	Tension On command	Bit	0 – Tension off 1 – Tension on
70.11	Select Tension Set Point from parameter 70.08	Bit	Tension Reference selection 0 – Analog parameter 07.01 1 – Digital parameter 70.08
08.02	Inch reverse command	Bit	When set with the tension and the inch forward off, the winder will inch in the reverse direction at the inch speed defined in parameter 16.14
08.03	Inch Forward command	Bit	When set with the tension and the inch reverse off, the winder will inch in the reverse direction at the inch speed defined in parameter 16.14
15.30	Select second diameter preset parameter 01.19	Bit	15.30 =0 Preset from 15.17/70.51 15.30 =1 Preset from 01.19/70.52
08.05	Run	Bit	When tension is on (15.23=1) and Stall select parameter 16.32 = 0, 0 - Stall tension ref. is applied. 1 – Run tension ref. Is applied When tension is off (15.23=0) 0 – Stop 1 – Run at line speed or registered speed. See Control state diagram
15.31	PID Enable	Bit	0 – Disable PID 1 – Enable PID. In Torque mode PID enabled above Diameter HOLD speed. In Speed Mode PID enabled after centring completed. Only use if load cell or dancer is fitted.
15.32	PID Hold integral	Bit	0 – Normal integration 1- PID Hold integrator
15.33	PID Reset integral	Bit	0 – Normal integration 1- Reset Integrator.
15.37	Coupling enable	Bit	0 – Stop 1 – Run at coupling speed(70.40) with current limit set (70.41)

Special Serial I/O Parameters

These parameters are used to control the function of the winder software and are intended only for use via serial communications.

No.	Description	Units	Comments
73.01	Line speed	0 -16000	Equivalent to 0 –Max Line Speed
73.02	Line acceleration rate	0 -16000	16000 equivalent to acceleration rate of 0 – Max line speed in 1 second
73.70	Control word 0		Allows sequence control via serial communication, see manual for bit allocation
73.71	Control word 1		Access to turret winder functions via serial communications, see manual for bit allocation
72.70	Winder status word 1		Allows winder status to be interrogated via serial communication see manual for bit allocation
72.71	Winder status word 2		Allows winder status to be interrogated via serial communication see manual for bit allocation

5.5.3 Saving Parameters

These parameters configure the operation of the winder software and should be set and saved within the drive.

To save Mentor parameters to non-volatile memory:

- Menus 0 - 16
Set parameter 00.00 = 1 and press the reset button.

- Menu 70 - 71
Set parameter 14.16 = 1. This parameter will automatically reset to 0.

6 Commissioning Sequence



7 Functional Description

7.1 Overview

The diagram below illustrates the basic functions provided by the Winder application. Alternative operating modes ensure maximum flexibility of the package to suit the majority of centre driven winder requirements. The user interface is completely configurable allowing this application to be incorporated into complex systems where additional features may be required.

Winder Control Block Diagram

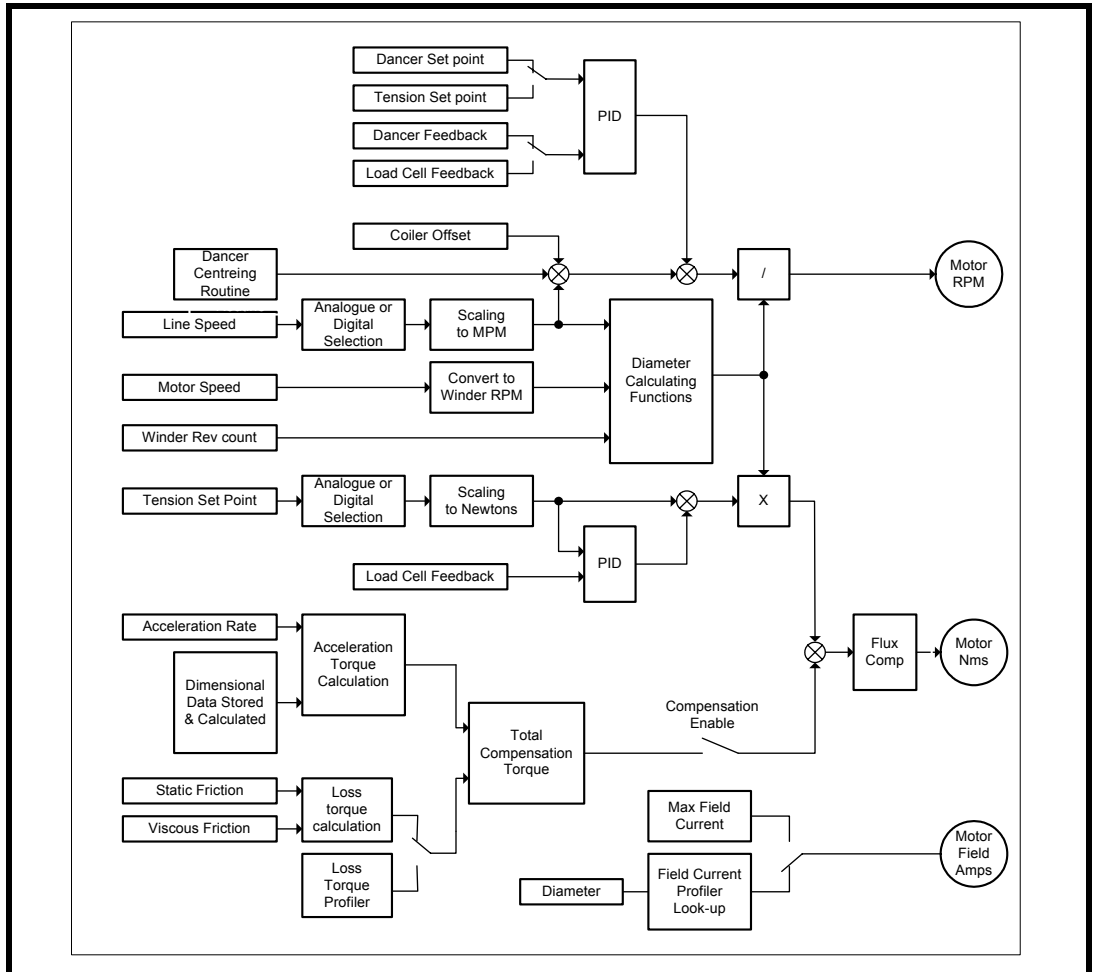

The Mentor winder software contains several basic calculation and control functions. Detailed overviews of the three basic blocks are shown below. A more detailed explanation is given under the relevant subheadings.

7.1.1 Standard or Back EMF Winder Control

Operation is possible using motors with constant torque, constant power or combinations of constant power and constant torque characteristics.

In the default (standard) mode the application will handle motors of any characteristic. Armature voltage being maximised throughout the speed range, field weakening only being introduced when the winder exceeds motor base speed.

Alternatively Back EMF control may be selected (15.20.7 = 1), this form of control is only suitable for motors having a constant power operating range, where the field flux is varied in relation to diameter.

The two approaches differ in the effect on the motor armature voltage and current as the diameter changes. In standard mode the motor voltage varies with both diameter and line speed as the torque available from the motor is always optimised to it's maximum level by the effect of the field controller which only applies field weakening when motor base speed is exceeded. Using classic Back EMF mode where the motor field range is matched to the diameter range, the motor voltage is always directly proportional to the line speed and the armature current remains constant throughout the diameter build up.

The Back EMF mode of operation allows the user a very simple means of checking performance. Once target line speed is attained both the voltage and current of the motor should remain constant for a fixed level of tension. Because operation in the standard mode relies upon weakening the field only when base speed is exceeded, which can occur at many combinations of line speed and diameter, no clear relationship between line speed, diameter and easily measurable motor parameters.

However because constant tension winding is basically a constant power application, a guide to performance under both modes of operation, can be by checking for a constant product of motor current and voltage.

Simple Back EMF winder field controllers maintain the correct level of armature voltage by matching armature voltage feed back against line speed. This arrangement has two distinct problems, firstly the motor must have a field weakening range equivalent to the full diameter build up ratio and secondly it is difficult to maintain the correct flux level at reduced speeds.

These problems can be overcome by controlling the field current to follow a profiler which has been programmed with the correct relationship between diameter and field current, the profiler can allow for a constant torque region where the field current must remain constant and so removes the necessity for the motor field range to fully match the build up ratio. This is the arrangement provided in this application.

The following diagrams are provided to indicate the exact relationship between tension torque, motor voltage, flux and armature current under the various operating conditions.

STANDARD MODE (CONSTANT TORQUE)

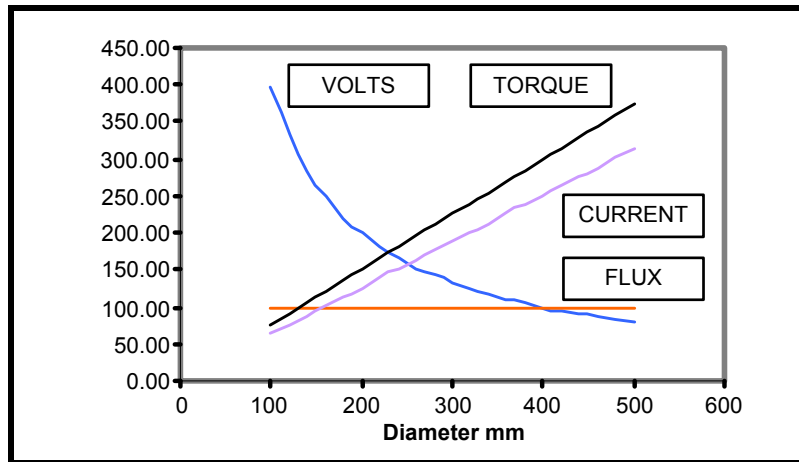

The diagram above shows the simplest arrangement using a constant torque motor, the flux remains constant throughout the diameter range and the voltage reduces in line with the RPM as the diameter increases.

STANDARD MODE (CONSTANT POWER / CONSTANT TORQUE)

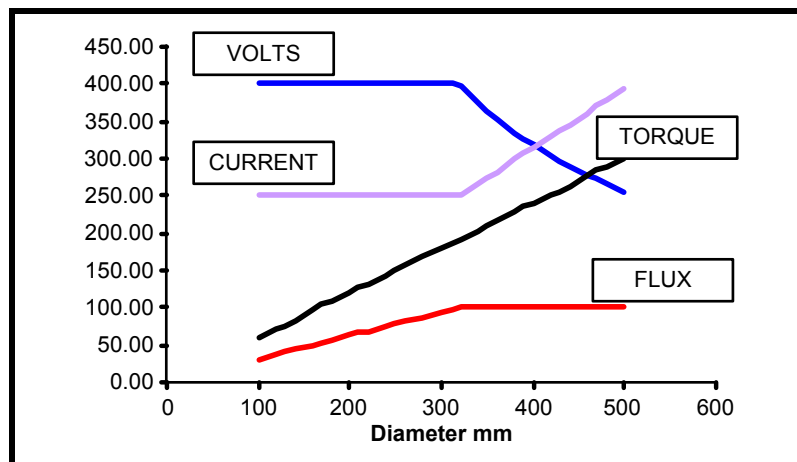

This diagram shows the effect of introducing a partial constant power characteristic, where the motor is field weakened to achieve the higher speeds at reduced diameters. This has the effect of reducing the range over which the armature current must be controlled, resulting in a reduced converter rating. Note that the armature voltage remains constant once base speed has been exceeded, this will occur at lower diameters if the line speed is reduced.

**STANDARD MODE (CONSTANT POWER / CONSTANT TORQUE)
AT REDUCED LINE SPEED**

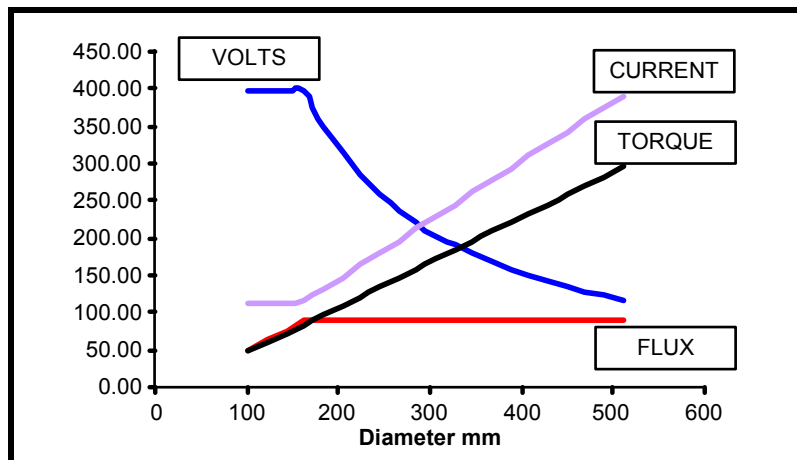

The diagram above shows the same motor drive combination, but operating at 50% line speed. As line speed reduces the operation tends more towards using only the constant torque range of the motor.

BACK EMF MODE (CONSTANT POWER)

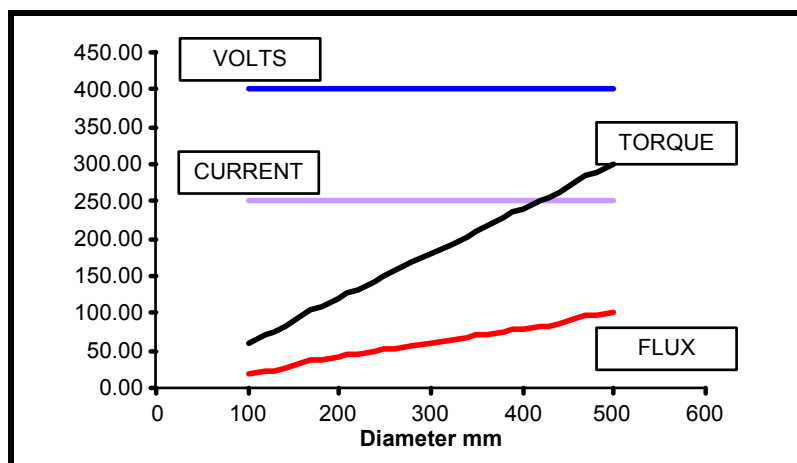

Operating in Back EMF mode maintains the voltage and current constant throughout the diameter build up range. The voltage will be reduced as the line speed is reduced but for a particular tension setting the current will remain constant. Torque variation is achieved only by adjusting the flux.

7.1.2 Speed and Tension Referencing overview

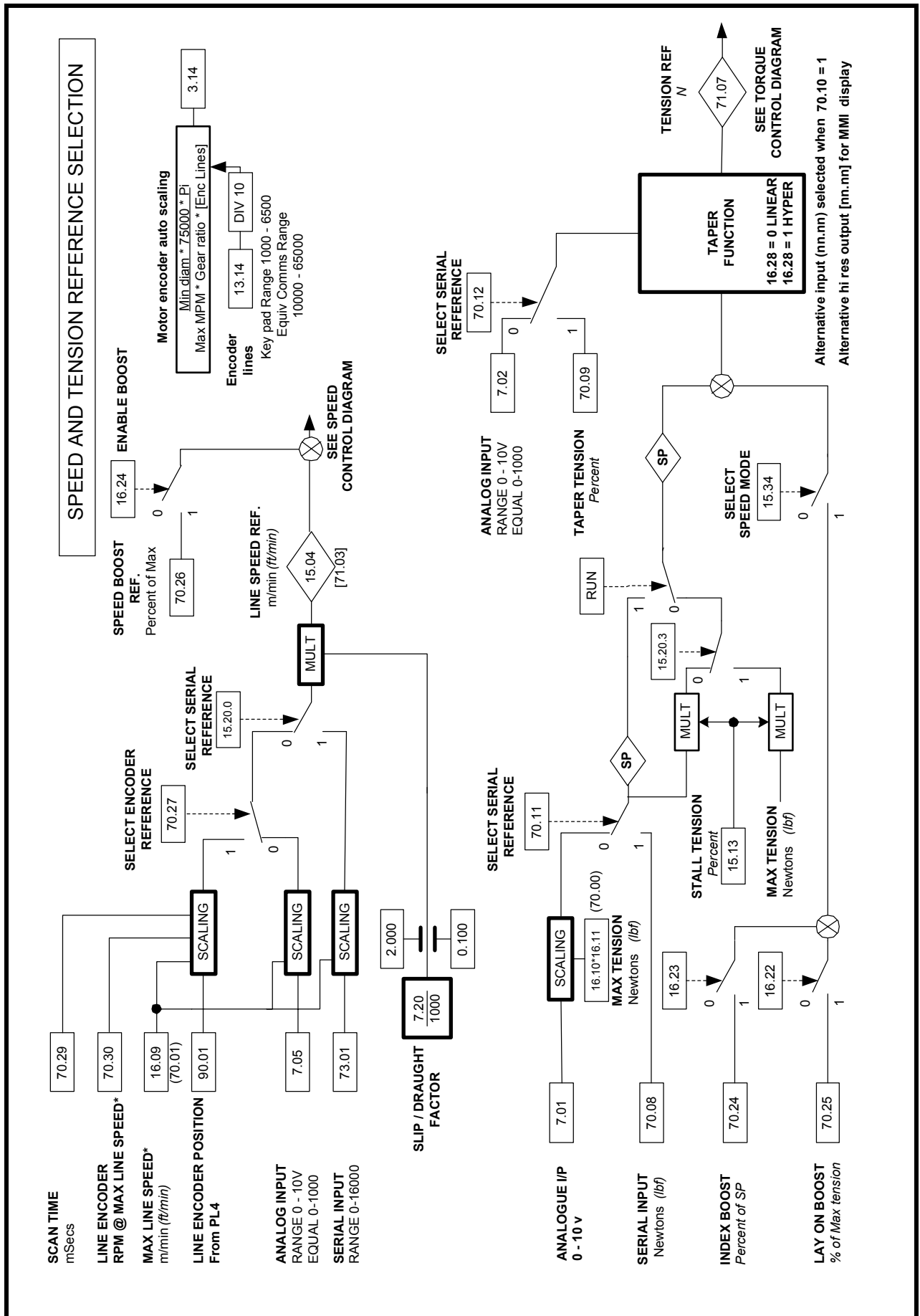

7.1.4 Tension Torque overview

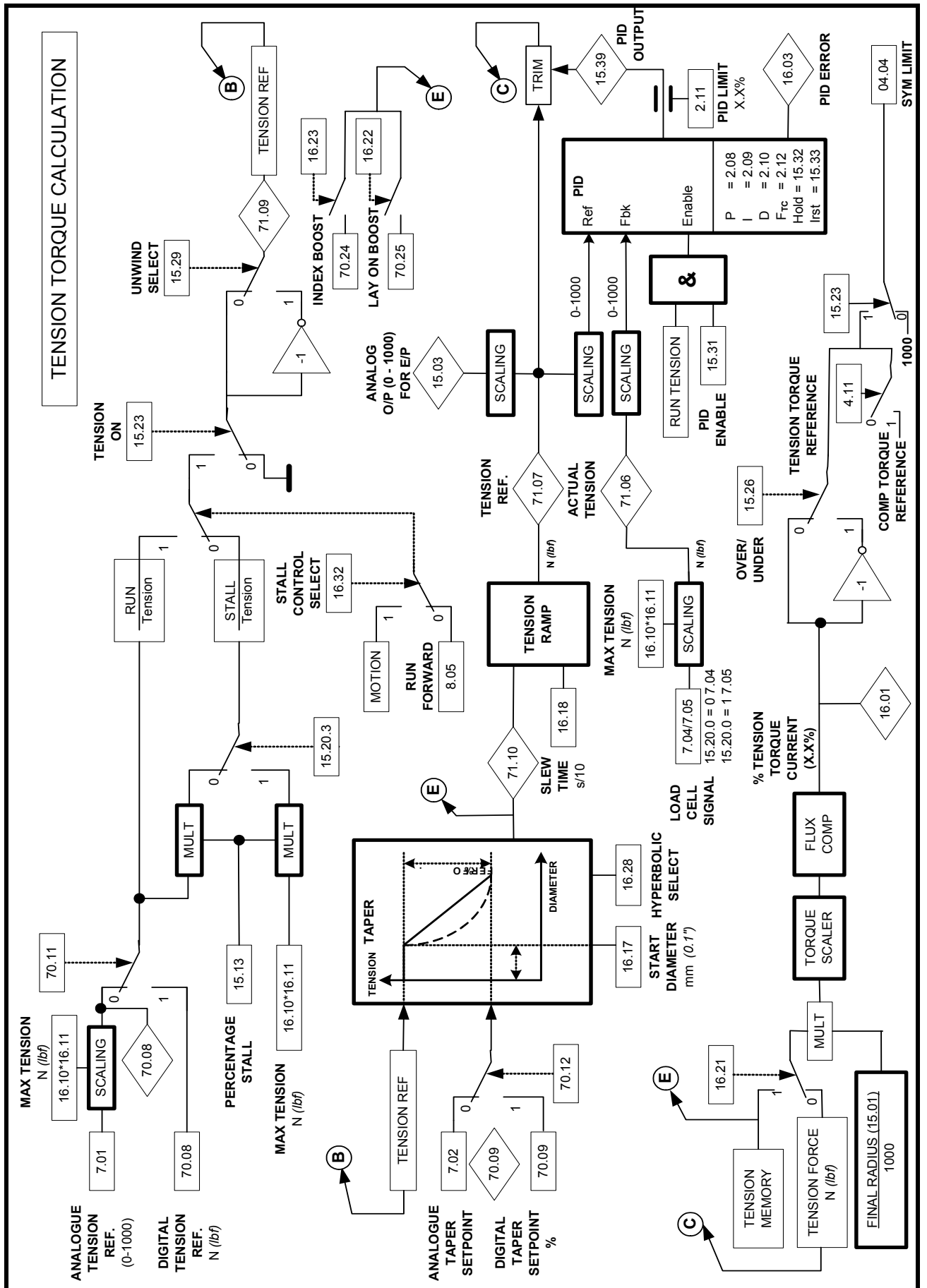

7.1.5 Inertia and Friction Torque Compensation overview

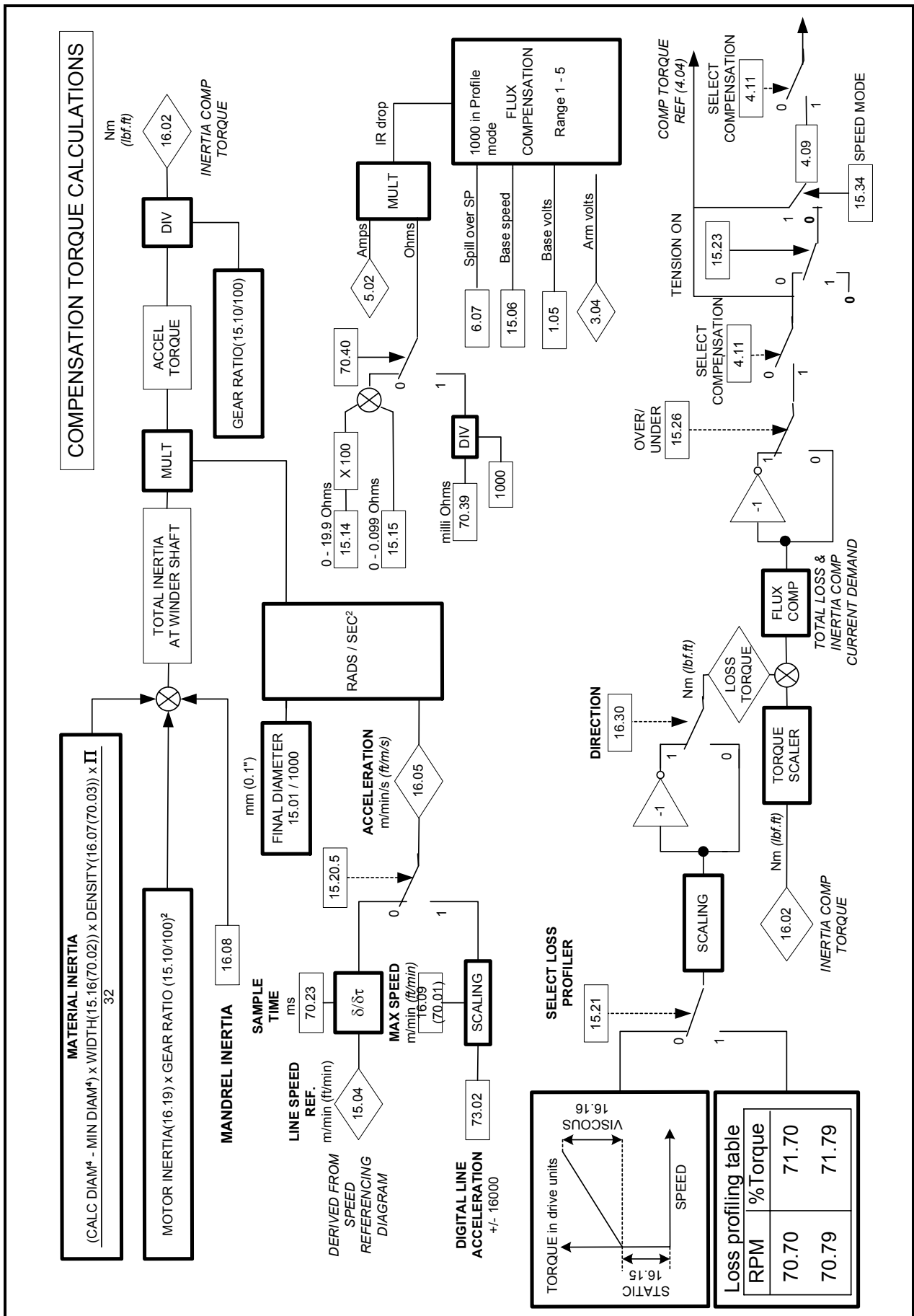

7.1.6 Speed Referencing overview

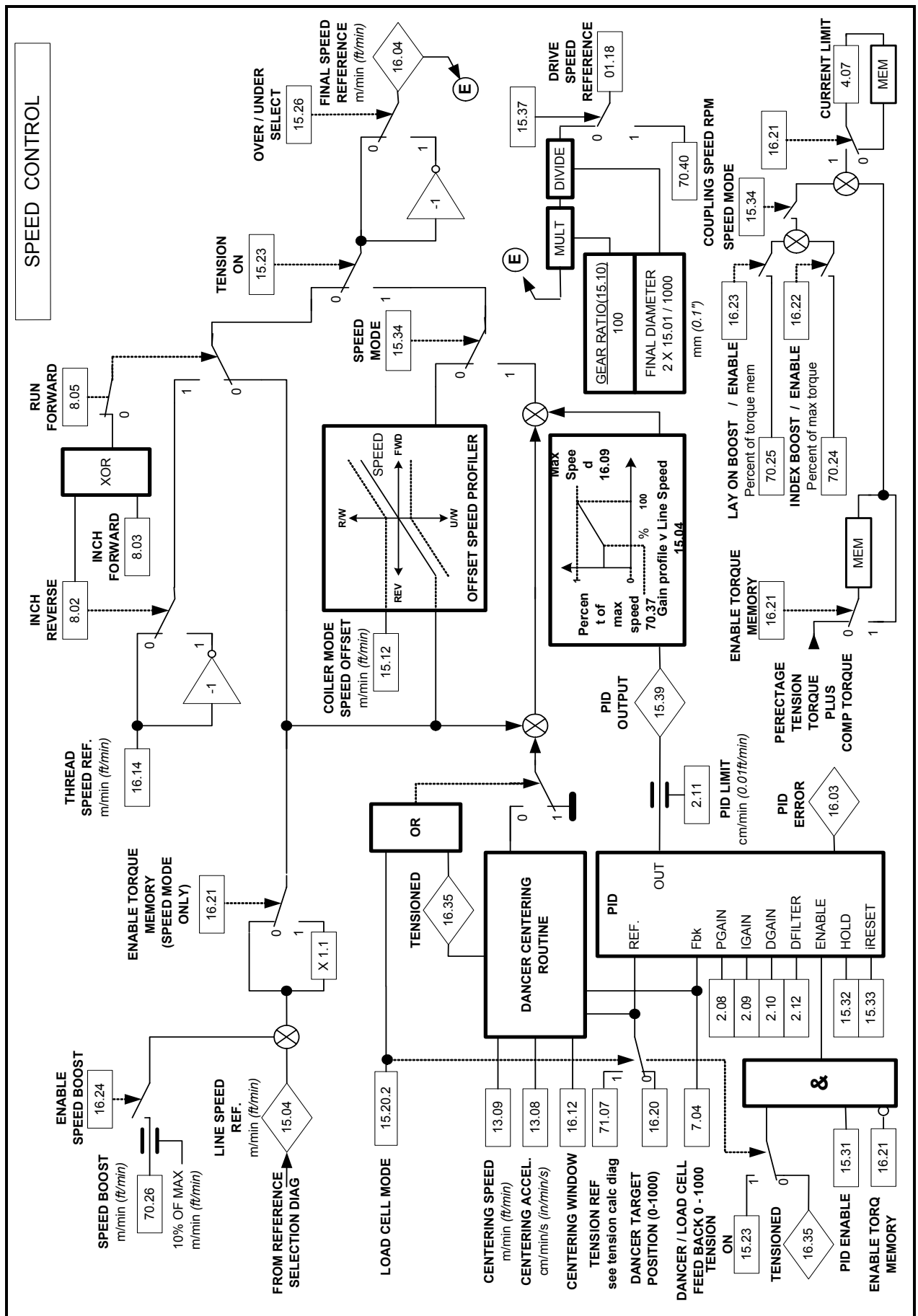

7.2 Set Point Data Scaling & Selection

All active analog data received by the software is scaled into the relevant engineering units before being passed to the calculation blocks. A set of scaling parameters is provided for this function. Each scalar must be set to the maximum value for the specific application in the correct engineering units. Input data is scaled as follows:

$$\text{Value in EGUs} = \frac{\text{Analog I/P value} \times \text{Scalar}}{\text{Analog scaling range}}$$

Where the scalar is equal to the maximum value in EGUs

Scalars are provided to convert:

Input Data	Type	Data Range	Max Parameter (scalar)	EGU
Line speed	Analog	1000 (07.05)	16.09/70.01	m/min
	Digital	16000 (73.01)	16.09/70.01	m/min
Tension	Analog	1000 (07.01)	16.10*16.11 /70.00	N
	Digital	N (70.08)	-	N
Diameter	Analog	1000 (07.03)	1.17/70.05	mm
	Digital	mm (70.05)	-	mm

- The analog and digital line speed references are both scaled by the same EGU scalar, range selection is determined by the signal source.
- Alternative menu 70 registers are provided to accommodate scalar values outside of the range of the Mentor standard parameters. The alternate scaling registers are selected as a single group together with alternate dimension data registers when 70.10 = 1.

All analog data must conform to the pre-assigned input terminals listed above, scalars are arranged to anticipate a range of 0 - 10 Volts.

Line speed digital data received via CTNet or directly from other field bus sources should be scaled over the range 0 - 16000 in order to maintain optimum resolution no matter at what speed the line is intended to operate, maximum speed is always being represented by 16000.

Where data is available from either analog or digital sources an individual selection bit is provided for each data channel, allowing a combination of analog and digital inputs to be selected. The status of the selection bit also determines the scaling range constant to be used in the conversion to EGUs.

Set point data which is input digitally is not scaled and should be entered in the relevant engineering units, For example Tension set point should be provided in Newtons directly from the MMI.

7.2.1 Use of Current Limit functions

The Mentor is provided with both symmetrical and polarity conscious current limit set up parameters. This application uses the symmetrical current limit 4.04 to control the current delivered to the motor when operating in torque control mode and also to set the torque level when operating in torque memory when using speed mode. User current limiting should therefore be set up using parameters 4.05 and 4.06 the forward and reverse bridge current limits. These should obviously be set to a value higher than the anticipated current required for tension control.

Removal of the run permit signal at terminal 21 will cause all references to be removed from the drive resulting in deceleration to zero speed, the rate of deceleration will be determined by the forward or reverse current limit setting. This function therefore provides a very simple method of achieving a rapid stop in the event of an emergency. Obviously during the stopping period the drive enable terminal 31 must remain enabled and the contactor closed.

7.2.2 Control Sequencing

The sequence control system should be designed to ensure that the drive is only enabled after the contactor has closed and is disabled before the contactor opens. The application inch and run functions should only operate whilst the run permit remains enabled.

To ensure correct operation of the drive enable it is advantageous to use a contactor pilot relay, this arrangement ensures the correct late make early break of the drive enable in relation to the contactor operation.

A typical sequence control diagram is shown below, additional functions eg Tension On, Diameter Preset may be added to suit the user requirements.

The user should ensure that the necessary safety features are incorporated, e.g. ultimate power isolation in the event of emergencies, etc.

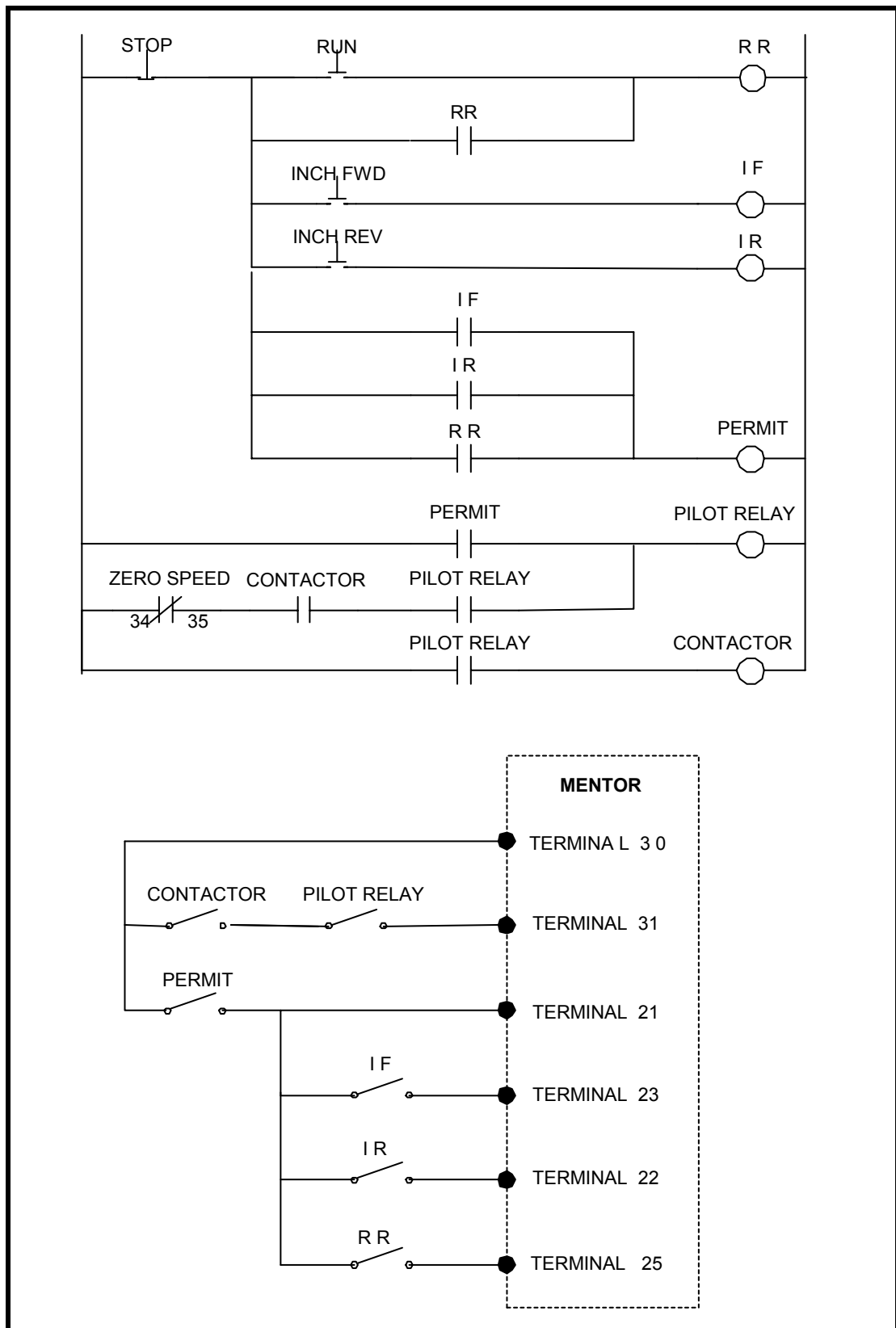

If the sequence control is to be performed by a PLC with a field bus link to the drive, then the contactor may be operated from the PLC via bit 10 of Control Word 1 (73.70.10) which is assigned to switch parameter 13.12. This parameter may be programmed by the user to operate a drive digital output.

7.2.3 Line Speed Reference Sources

1. Analog 15.20.0 = 0, 70.27 = 0

The line speed reference used by the winder control software may be obtained from several alternative sources. In the default condition an analogue source operating over the range, 0 - 10 volts or 0/4-20mA is used and an analog input should be connected to terminal 3. Internally 10 volts will be represented by the maximum line speed value in 16.09/70.01 and the actual line speed reference in MPM (FPM) can be read in 15.04 (limited to 1999) or 71.03 (unlimited).

NOTE Dancer or Load cell analog feedback connected to terminal 7, (0 – 10V signal, 10bit resolution).

2. Encoder 15.20.0 = 0, 70.27 = 1

If the winder is to follow an encoder reference connected via PL4 then 70.27 should be set to 1, the encoder input frequency is then scaled using the line encoder count per rev, and:

70.29 Line encoder time base default 10 mSecs

70.30 Line encoder RPM at Maximum Line Speed

The result may be read in 15.04 in MPM (limited to 1999) or 71.03 (unlimited).

NOTE Dancer or Load cell analog feedback connected to terminal 7, (0 – 10V signal, 10bit resolution).

3. Serial 15.20.0 = 1

Setting 15.20.1 = 1 will provide the speed reference from 73.01 which is suitable to receive a cyclic transfers via CTNet from the upstream master drive. This signal should be scaled 0 – 16000 to represent 0 – Maximum Line Speed. It is internally calibrated by 16.09/70.01 and the result may be read in 15.04 in MPM (limited to 1999) or 71.03 (unlimited).

A serial speed reference may be provided from any device capable of writing to 73.01, but the signal must conform the correct scaling 0 – 16000.

NOTE Dancer or Load cell analog feedback connected to terminal 3 for higher resolution feedback, (0 – 10V or 0/4-20mA signals can be used, 12bit resolution).

The Line encoder parameter must be deselected' 70.27 = 0.

7.2.4 Length Count

Where the speed reference is provided from a line encoder a material length count is also provided, the count appears in 70.19 and a count reset function is provided by 70.38.

7.2.5 Reference polarity and direction of rotation

In order to ensure correct operation of the software and achieve the required direction of rotation of the winder the following conventions must be followed.

All rotations are defined as looking on the front side of the winder (opposite side to the motor) and on the shaft end of the motor. If the installation employs either a direct drive or a belt drive both motor and winder directions of rotation will therefore be similar.

Default is considered as clockwise when following a positive line speed reference signal. Transporting material from an Unwind to a Rewind.

If the resulting direction of rotation of the re-winder is not as required then it may be reversed, by setting 15.26 = 1. If this results in the motor rotating anti clockwise then the diameter calculation by Lap counting will be incorrect, decrementing instead of incrementing, this can be corrected by setting 16.25 = 1. Conversely if the drive is selected to operate as an Unwind the diameter should decrement when running in the forward direction.

The drive may be selected to operate as an Unwind by setting parameter 15.29 = 1, this reverses the relevant signals internally producing a negative value for the tension reference in torque mode and reversing the action of the dancer centring routine in speed mode.

Operation in Under or Over wind may be achieved by changing the setting of 15.26.

If the system is required to reverse, passing material from the drive defined as Rewind to the drive operating as an Unwind, this is simply achieved by providing a negative line speed reference signal. No changes are necessary to the Unwind / Rewind selection bit 15.29 **as the required torque directions do not change.**

Negative line speed reference should only be used when reverse operation is required.

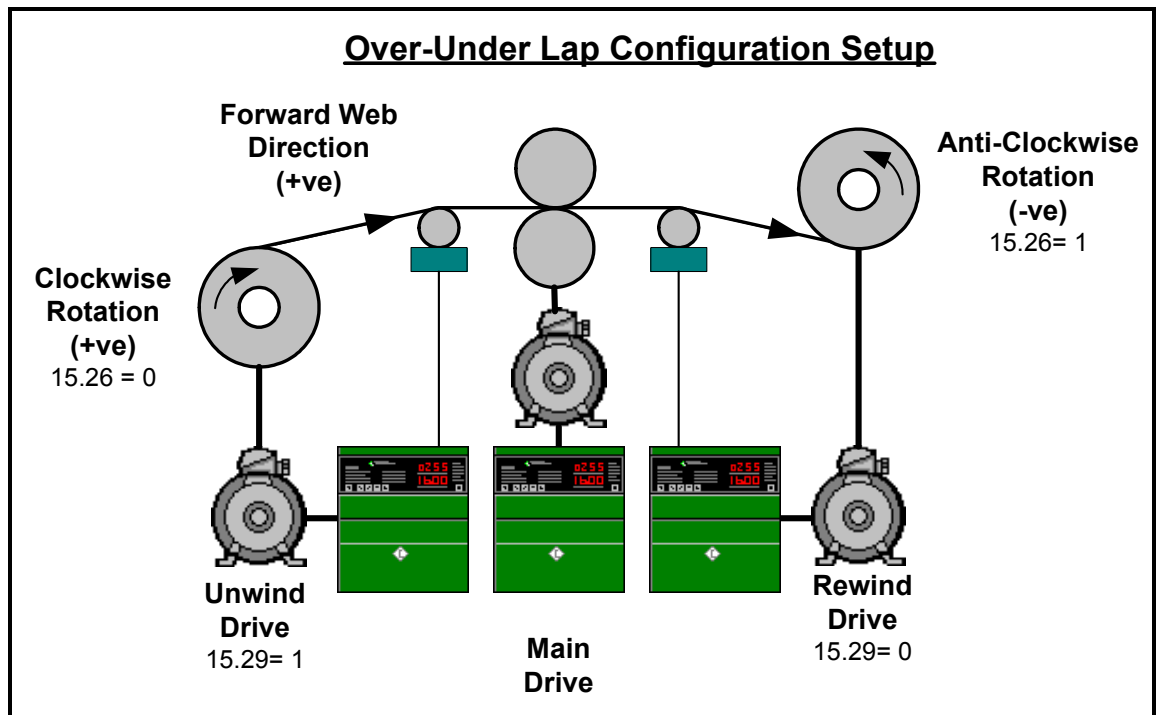

Positive line speed reference

No reversal between motor and winder

Winder rotn	Motor rotn	15.26	16.25
CW	CW	0	0
CCW	CCW	1	1

Reversal between motor and winder due to gearbox

Winder rotn	Motor rotn	15.26	16.25
CW	CCW	1	1
CCW	CW	0	0

If a drive is selected as an Unwind the settings above still apply, reversal of the line speed reference will result in the rewind operating as an Unwind and the Unwind operating as a Rewind. No changes to the configuration will be required.

7.2.6 Speed Referencing (Torque Mode)

The following diagram illustrates the arrangement for line speed reference selection and scaling when operating in Torque control mode. The analog line speed reference is permanently configured to terminal 3. Setting 70.10 to 1 selects 70.01 as the line speed scaler.

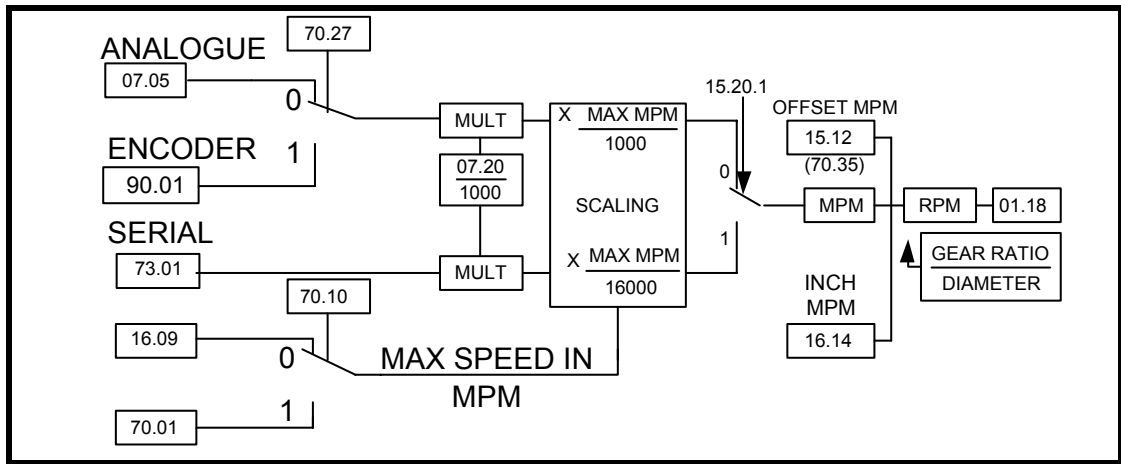

7.2.7 Speed Referencing (Speed Mode)

The following diagram illustrates the arrangement for line speed reference selection when operating in Speed control mode. The analog line speed reference is permanently configured to terminal 3. Setting 70.10 to 1 selects 70.01 as the line speed scaler.

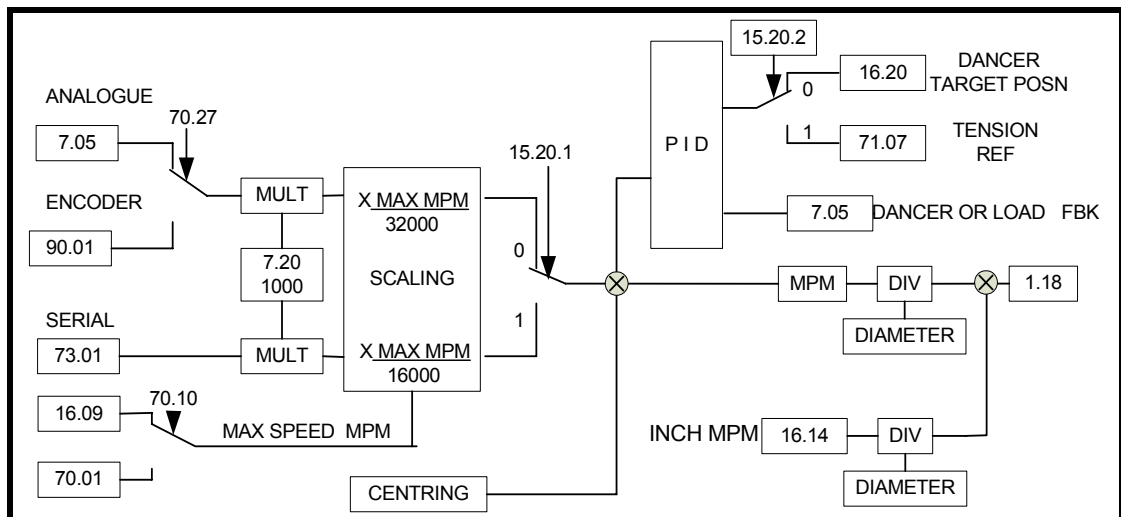

7.2.8 Tension Referencing (Torque Mode)

The following diagram illustrates the arrangement for Tension set point selection when operating in Torque control mode

The analog Tension set point is permanently configured to terminal 5. Setting 70.10 to 1 selects 70.00 as the scaler for maximum tension.

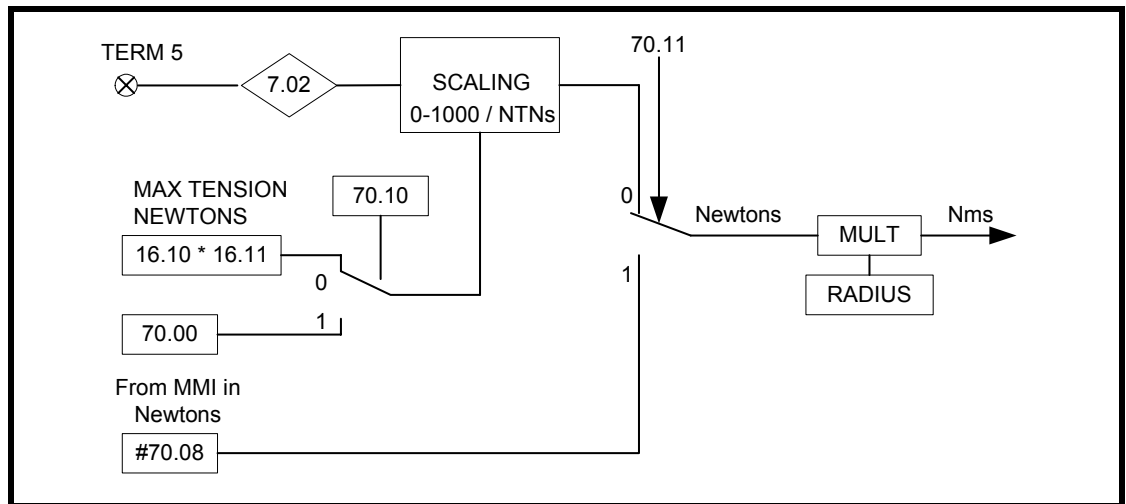

7.2.9 Diameter Referencing (Direct measurement)

The following diagram illustrates the scaling and selection applied to direct diameter input via an analog input channel.

The analog diameter set point is permanently configured to terminal 6.

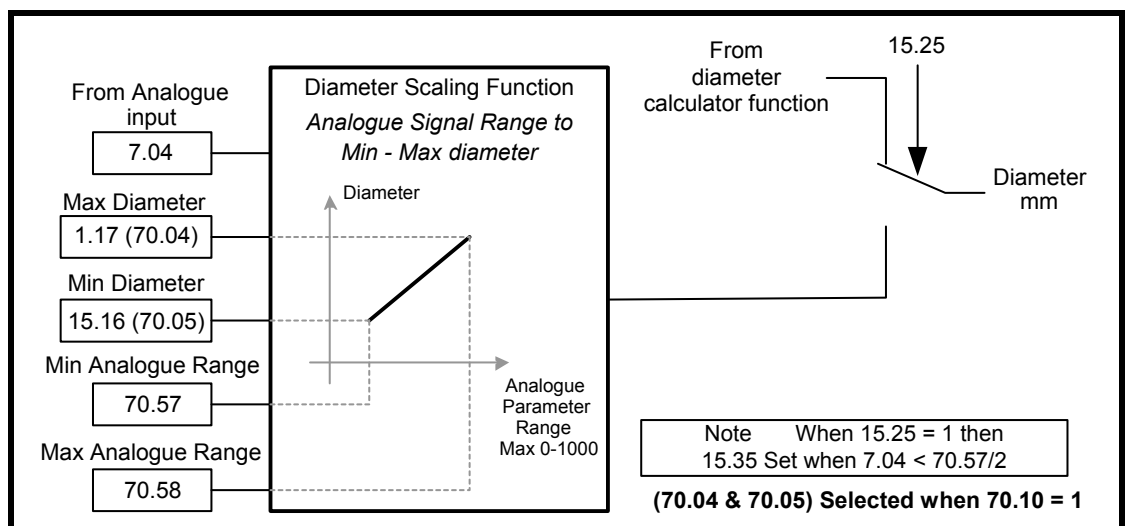

7.3 Diameter Measurement and Calculation

An accurate value of winder Diameter is essential if the software is to maintain accurate control over the winder. The choice of method for diameter measurement is often determined by the particular application and to ensure maximum flexibility four options are provided.

1. By calculation – Speed Ratio (15.20.1 = 0: 15.25 = 0)

Using the relationship:

$$\text{Diameter} = \frac{\text{Line Speed in m/min}}{\text{Pi} * \text{Winder Speed (r/min)}}$$

Parameter 3.12 determines selection of Tacho or Encoder as the source of motor speed measurement.

3.12 = 0 selects feedback from a tachogenerator

3.12 = 1 selects feedback from an encoder

If the motor speed feedback is obtained from an encoder then once maximum line speed 16.09, minimum diameter 15.18, gearbox ratio 15.10 and the number of encoder lines have been entered in parameter 13.14 the drive speed will be automatically calibrated.

But if the motor speed feedback is derived from a tacho-generator then this is not possible and the user is responsible for scaling the feedback signal to achieve the correct motor speed.

Maximum line speed, minimum diameter and gearbox ratio are used by the software to calculate the maximum speed required from the motor which is displayed in 71.08, if no access by serial link is available this value may be inspected from the keypad via 15.50 (high part) and 15.51 (low part).

The tacho feedback signal for diameter calculation is derived from the virtual parameter 91.06, which has a range of 0 - 16000 this is converted by the software into RPM using 71.08 as a scaling factor. It is essential that the user correctly calibrates the tacho-feedback signal, using Switch 1 bits 6,7 & 8 and Potentiometer RV1 on the MDA2 board. Such that a value of 16000 (equivalent to 1000 in 3.26) coincides with an actual motor speed equal to the value displayed in 71.08.

After calibration the display of actual motor speed in RPM from 71.05 (Keypad 16.38, 16.39) and winder RPM in 15.05, could be checked against a hand tacho to establish that scaling has been performed correctly.

2. By calculation - Lap Count (15.20.1 = 1: 15.25 = 0)

Using the relationship:

$$\text{Diameter} = \text{Preset} + (\text{Material Gauge} * 2 * \text{Rev count})$$

3. By calculation – Traverse Lap Count (15.20.1 = 1: 15.25 = 0: 16.27 = 1)

Using the relationship:

$$\text{Diameter} = \text{Preset} + (\text{Cable diameter} * 2 * \text{Traverse reverses})$$

4. By direct measurement (15.25 = 1)

Using a transducer

Method 1 (Speed Ratio)

This method is selected as default and is suitable for applications where a constant relationship between the speed of the master drive and the material is assured. Known slippage or draught effects can be catered for using the Slip Factor adjustment.

Because this method uses active values of line speed and winder speed it is self-correcting and will recover from errors due to incorrect preset diameter values entered by operators. However the calculation may only be performed above a minimum speed at which the speed feedback information becomes sensible. Various factors are provided to automatically freeze the calculation when data becomes unreliable see Diameter Hold.

Problems can occur when using this method due to variations in the speed signals causing transient disturbances to the calculated result, this leads to disturbances in torque output and hence tension. This effect has been minimised by limiting the rate at which the calculated diameter result is allowed to change - see Slew Limiting.

Method 2 (Lap Count)

This can be selected (15.20.1 = 1) for applications where the speed of the material does not directly relate to the speed of the master drive. Typical examples include reducing mills where a considerable increase in material speed takes place due to the reduction process.

When using this method accurate data must be provided for diameter preset value and material gauge, as the system has no means of correcting any initial errors.

Inaccuracies in gauge will cause an integral build up in the diameter result as winding progresses. In the metal processing industries where this approach is normally used these potential errors are not usually of any significance.

Because the lap counting function is based upon encoder position the direction of count may be incorrect for the particular set up, encoder direction will not necessarily comply with winder rotation due to gearing. Reversal Bit parameter 16.25 is provided to allow the increase or decrease in diameter to be matched to the actual arrangement.

Diameter should increment for a rewind drive running in the forward direction (positive line speed reference) and decrement for a un-wind. Correct direction of winder rotation can be achieved using the over / under wind selection bit parameter 15.26.

Method 3 (Traverse Lap Count Mode)

This is an option to Method 2 and is selected when parameter 16.27 = 1, it is intended for cable traverse applications (rewind), where the diameter is increased by the twice the cable thickness at each reversal of the traverse. Traverse reversals should be signalled via parameter 16.26. Cable thickness should be entered as gauge in microns.

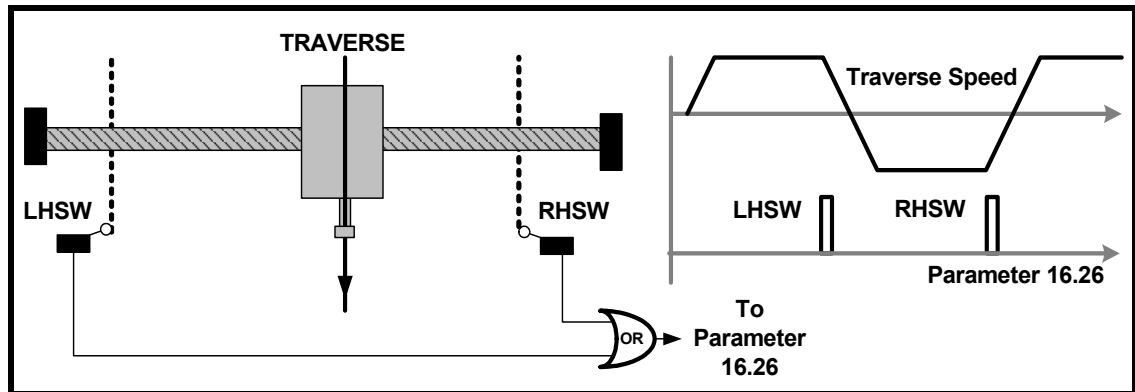

The Traverse mode may also be used for conventional web type materials where a once a revolution signal is generated from the machine, it is arranged to increment for rewind and decrement for unwind modes. The traverse counter must be preset in exactly the same manner as the normal lap counter.

Method 4 (Direct Measurement)

This method is selected when parameter 15.25 = 1 can be used when some form of diameter sensing transducer is supplied. The transducer should be scaled to produce 0 – 10 volts in relation to the diameter range Minimum diameter – Maximum Diameter. This signal will then be correctly re - scaled by the software and will be displayed in millimetres in parameter 15.01 limited to 1999 and in full resolution in 71.01.

Often in Unwind applications a diameter sensing transducer may be fitted but only used to provide the diameter preset value before start up. Methods 1 or 2 are then selected to provide continuous update of diameter once the machine is operating. Analog input and scaling functions are identical when using the transducer for both direct measurement and diameter presetting.

When analog diameter measurement is selected the diameter signal is monitored and if it falls below 50% of the anticipated minimum value the web tracking error flag 15.35 will be set to warn against loss of the diameter signal. The level of analog input equivalent to minimum diameter should have been entered in 70.57.

Overview of diameter calculating functions

7.3.1 Diameter Preset

When diameter calculation is used then at the start of a new wind the calculator output must be preset to the correct value. This is performed by momentarily setting parameter 15.28 = 1. Parameter 15.28 will automatically reset when the preset is completed.

The diagram below illustrates the preset diameter function.

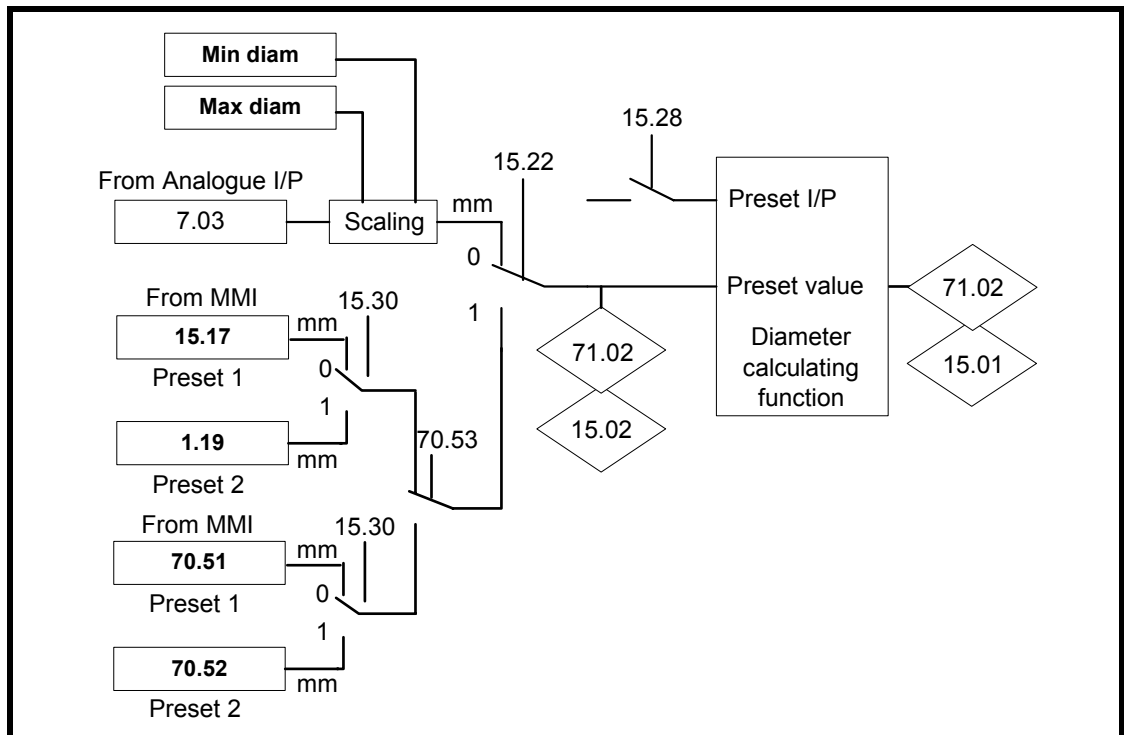

The preset action can only be performed when parameter 15.23 = 0, tension control not enabled.

Four preset diameter parameters are provided 15.17 and 1.19 accessed from the keypad or alternatively to provide a wider range, 70.51 and 70.52 selected when 70.53 = 1. All are calibrated in millimetres (tenths) the maximum value in 15.17 is 255 and the maximum value in 1.19 is 1000.

7.3.2 Diameter Slew Limiting

Variations in diameter due to misshaped rolls and noisy line speed reference signals can cause errors in the diameter calculation resulting in disturbances in torque and hence tension. This effect is reduced by imposing a limit on the rate at which the calculated result can change, the rate at which diameter will change depends upon the material gauge and the rotational speed of the winder.

The slew rate imposed by default is automatically calculated from this data, setting parameter 15.20.4 = 1 will select a user determined slew rate entered in parameter 16.13.

Additionally the direction in which the diameter calculator can move is polarised to match the duty.

During a forward pass

- Rewinds may only increase diameter

- Unwinds may only reduce diameter

During a reverse pass

- Rewinds may only reduce diameter

- Unwinds may only increase diameter

By applying these rules the software will prevent diameter errors due to run away under web break conditions.

7.3.3 Diameter Hold

At low speeds the result produced by the diameter calculator in ratio mode will become unpredictable. Levels may be set in parameter 15.11 in winder speed (r/min) and in parameter 70.36 in slew rate. Which determine the minimum acceptable levels below which the calculated diameter will be frozen.

The minimum slew rate is set on initial use to a default of 200.

An additional overriding user Hold function is also provided by setting parameter 16.33 = 1. The diameter calculator is also inhibited if a slack web is detected.

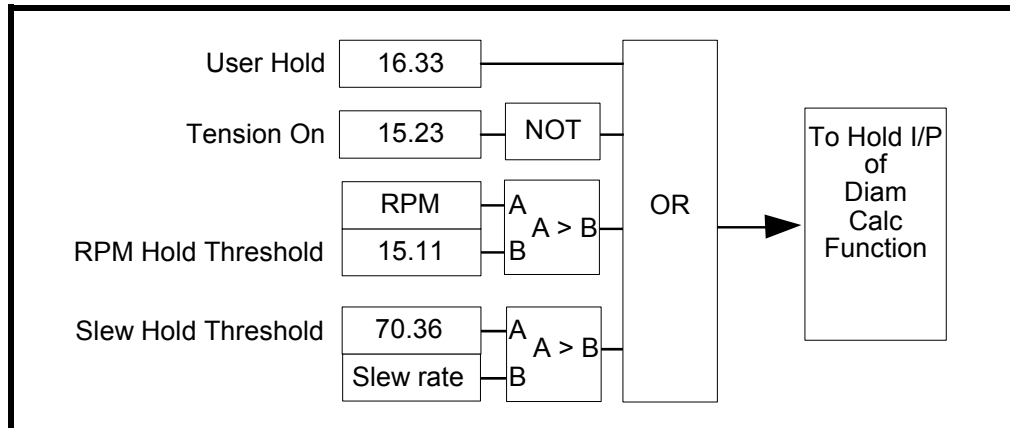

7.3.6 Coupling

The coupling function allows the winder to be rotated at constant speed referenced in RPM instead for MPM, whilst the coupling splines align ready for engagement. The speed reference is entered in 70.40 and the function is enabled when 15.37 is set on. Coupling is handled by the sequencer in a similar manner to the jog function, 15.37 should therefore be maintained on for the period during which rotation is required.

During coupling the drive current limit is reduced to allow stalling when the coupling engages, the coupling current limit level is entered in 70.41. Coupling speed may be set over the range of ± 10 r/min referred to the winder shaft.

7.3.7 Non Volatile Diameter Storage

No non volatile diameter storage is available in the Mentor.

7.3.8 Web Break Detection

Web breaks will cause a mismatch between winder peripheral speed and line speed this mismatch causes a sudden change in the calculated diameter and is detected by the software. Two levels of error are detected.

When using the winder in Speed mode the slack web detection flag is also used to detect a web break.

Parameter 15.35 is set if a small diameter error occurs.

To avoid trips due to transient conditions the error condition must exist for 500 milliseconds before the flag is set

This will indicate incorrect set up of the preset diameter or in lap count mode possibly an incorrect gauge setting.

Parameter 15.36 is set if a mismatch between calculated winder peripheral speed and line speed is detected.

A delay of 100 milliseconds is provided to filter out any transient errors.

This indicates a web break and will operate in both ratio and lap count diameter calculating modes.

When operating in torque mode the increase in winder peripheral speed is limited to the value set as coiler offset, the web break mismatch threshold is set at 50% of this value. In speed control mode the increase in speed will be limited by the clamp applied to the output of the PID speed trim, to overcome difficulties in detecting speed errors when the clamp is set to a low value, the PID in limit flag is monitored as a second factor in the web break detection function.

The web break flag is latched within the winder software until the drive is disabled. The tracking error flag is not latched. Neither of these flags generates any action within the winder software and they should therefore be monitored externally. Operation of either of these flags does not have any effect on the operation of the winder software.

When analog diameter measurement is selected the diameter tracking error flag 15.35 will be set if the analog signal falls below 50% of the minimum anticipated value set in 70.57

The tracking error and the web break trips, are inhibited by the Hold diameter and minimum slew rate thresholds. To prevent spurious trips occurring around zero speed, if increased sensitivity is required these thresholds may be reduced below the default settings.

7.3.9 Loss of Analog Diameter feedback

When the analog input is selected as the source of diameter measurement, the level of the signal received from the diameter measuring device is continually monitored if it falls below 50% of the anticipated minimum level the Diameter Tracking error flag 15.35 is set.

7.4 Taper Tension

Some materials wind more satisfactorily when the tension is reduced as the diameter increases.

The amount of Taper or tension reduction is set as a percentage achieved at maximum diameter. Reduction is performed linearly or hyperbolically and can either start from the mandrel diameter or a point part way through the diameter range.

Taper set point adjustment is made available in both analog and digital format. The diagram below illustrates the options for set up and control.

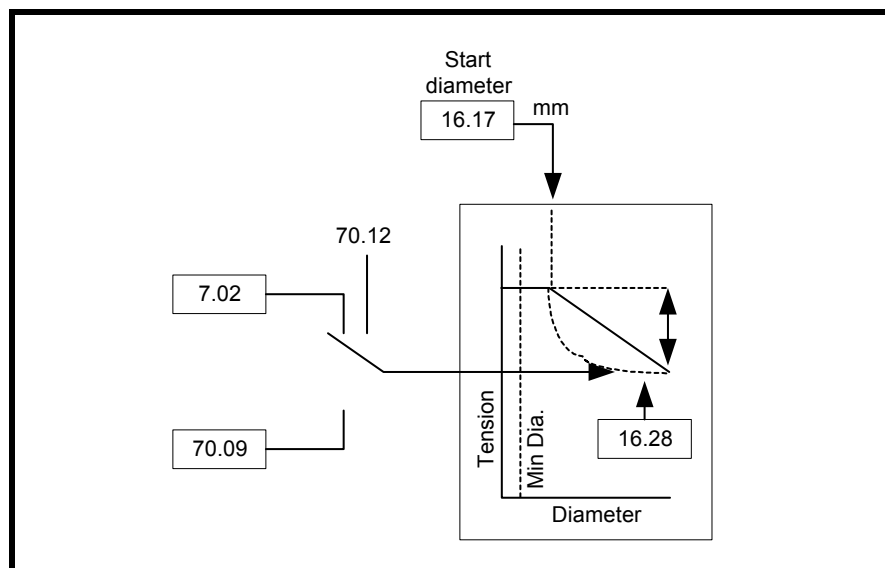

Normally Taper tension will not be available when operating a winder in Speed Mode as the control strategy is to maintain dancer position against a fixed restraint e.g. a spring. The tension is therefore determined by the spring rate.

If Taper Tension is required then the dancer mechanism must be arranged to accept a load reference from the drive, usually this is achieved using an E/P transducer controlled from an analog output and a pneumatically loaded dancer mechanism. In which case the system must be provided with Tension and Taper set point data as would be provided for a Torque winder. If a load cell is used when operating in speed mode then because a full tension control loop is in operation normal taper tension facilities will be available is provided in torque control mode.

7.5 Torque Compensation functions

Feed forward torque references are produced to compensate for winder frictional losses and inertia. These functions are not normally required when operating in Speed Mode, but systems requiring rapid acceleration may benefit from the use of inertia compensation.

Torque controlled winders operate by predicting the required torque to achieve tension, if the loss or acceleration torques are significant compared to the tension component then it will be very difficult to obtain satisfactory tension control.

Acceleration torque can be accurately predicted providing the correct dimensional data is provided at set up. However predicting the frictional losses of the winder is more difficult as losses tend to change with temperature and time. Where the losses amount to more than about 10% of the tension load then it is recommended to employ closed loop tension control using some form of direct tension measurement.

When operating in Speed Mode the compensation values are inputted to the drive via the torque offset parameter 04.09, therefore to enable compensation, parameter 04.11 must be set to 1. When operating in Torque Mode once "Tension On" is selected the Tension and Compensation torque values are summed and used to set the symmetrical current limit, bit parameter 04.11 is still used to select compensation torque whilst using 04.04 to set the torque level. When tension and compensation torques are input via the symmetrical current limit the torque offset 04.09 is continually written to zero.

In torque mode until Tension On is energised the losses are written to 4.09 to facilitate loss calibration while operating the drive under speed control. 4.11 is used to select loss compensation under all conditions.

NOTE

Winders should be designed to operate with the minimum friction load; worm reduction gearing should be avoided where possible. The best results will be obtained when the motor is directly coupled to the winder shaft. For small reductions in speed toothed belts provide a more efficient speed reducer than a gearbox.

7.5.1 Loss Compensation

Loss compensation can be split into two components losses due to static friction and losses due to viscous friction. The polarity of the loss compensation signal is dependant upon winding direction. When rewinding the losses have the effect of reducing the effective tension and the compensation torque must be added to the tension torque component. When unwinding the opposite condition exists and the loss torque must be subtracted from the tension torque. This polarity selection is performed automatically within the software by checking the polarity of the line speed reference signal. The loss compensation torque function is illustrated below.

The result is indicated by Compensation Current display parameter 16.02 which displays the sum of the loss and inertia compensation currents.

Two options are provided for programming the loss compensation. For simple set up two parameters, which set the percentage of static and viscous compensation are provided. This produces a simple linear compensation function. More complex functions may be achieved using a profile generator, which is programmed with values of percentage torque against motor RPM.

The profiler is selected when 15.21 = 1.

Compensation torques are calculated internally in Nms and not in drive units, the effect of flux compensation must therefore be taken into account when estimating the required values by reading drive torque demand in drive units (related to armature current). To overcome this difficulty a percentage torque demand value is displayed in 70.54, this value is the torque demand in drive units corrected for the effect of flux compensation and can be used as a guide when setting up either 16.16 or the torque demand values used to programme the profiler.

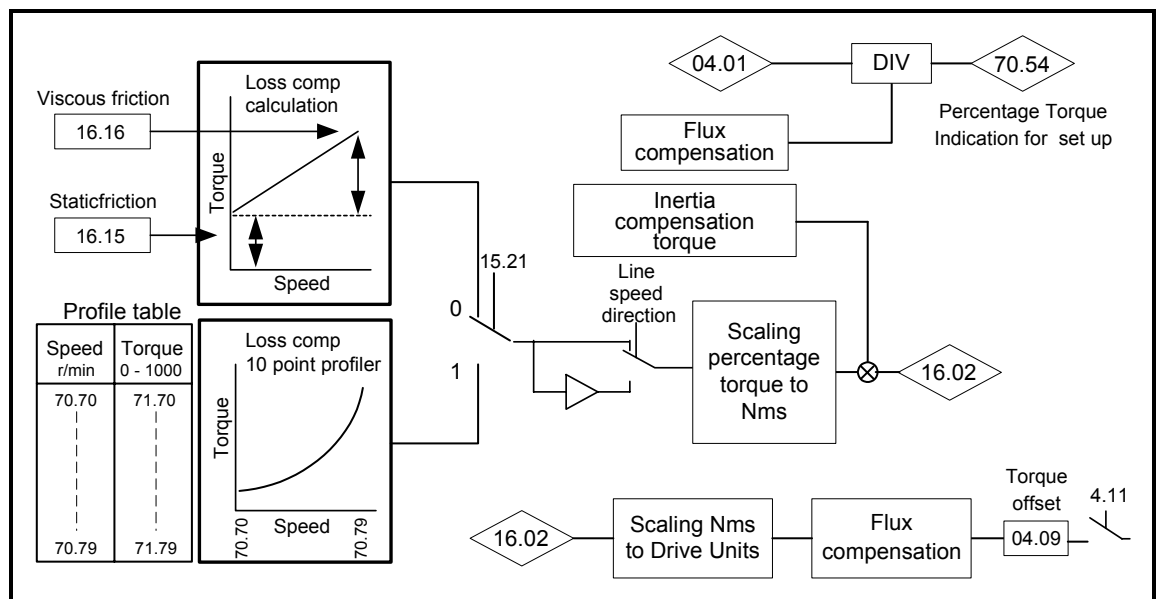

Simple Loss Compensation (15.21 = 0)

Loss compensation is split into two components losses due to static friction and losses due to viscous friction.

Profile Compensation (15.21 = 1)

Using the profiler the losses can be more closely matched to the load. The profile allows the losses to be entered at different speeds within the controllable range, up to 10 points maximum. The speed values are stored in parameter 70.71 to 70.79 and the corresponding percentage loss torque values are stored in parameters 71.70 to 71.79. The profiler uses linear interpolation between each point as the winder speed increases or decreases. The speed can be entered as positive or negative values, and therefore losses can be profiled for uni-directional or bi-direction winders.

See the following examples:

Uni-polar speed direction example

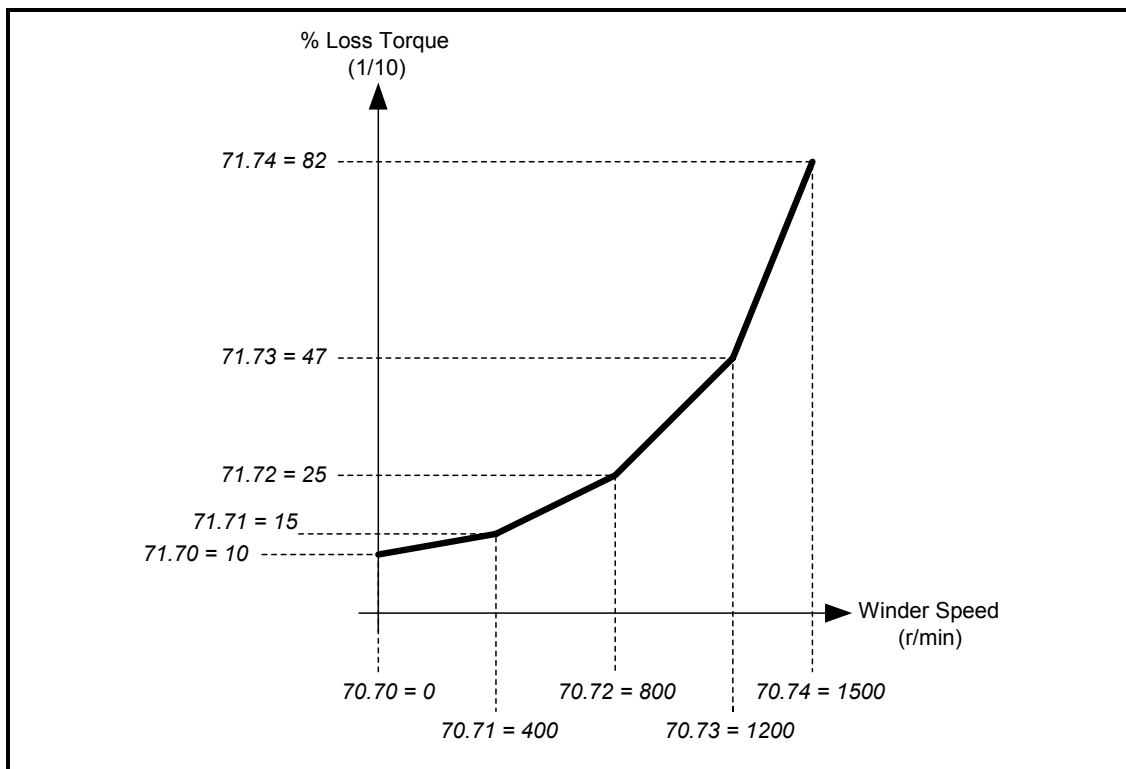

Bipolar speed direction example (Reversing Mill)

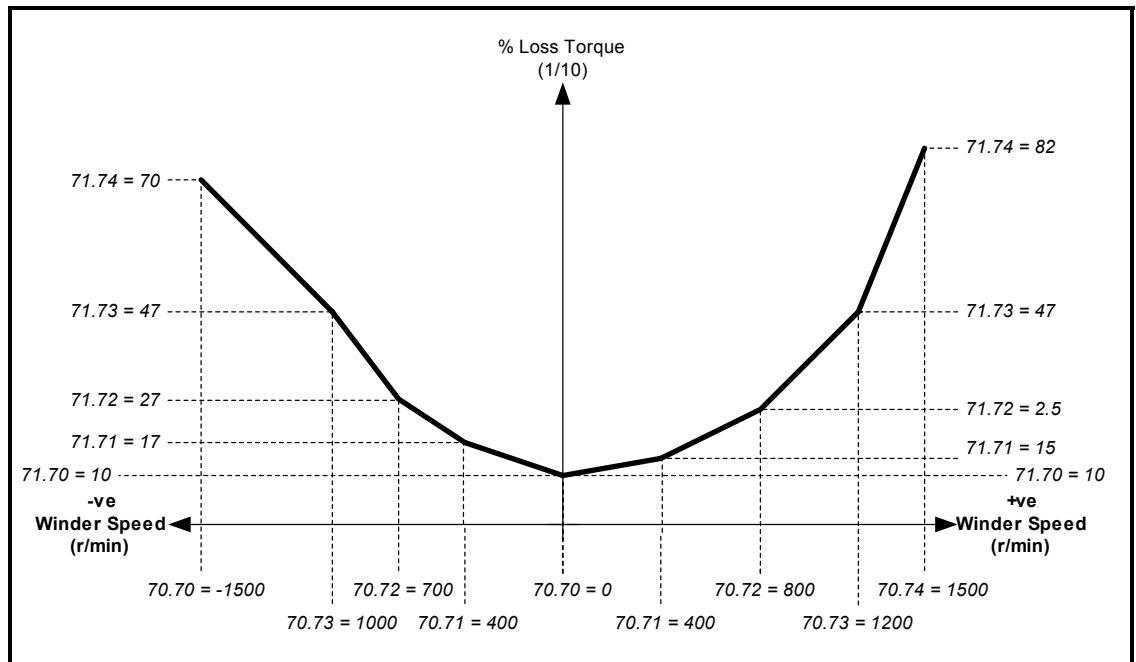

To measure the percentage loss torque for given speed values, the winder will have to run in speed mode without any material. The following procedure could be used:

1. Disable the Winder program.
2. Set 14.06 = 0
3. Set 14.16 = 1 This will save any MD29 registers already programmed and stop the Winder programme.
The drive will be set to follow 1.18 as it's speed reference.
4. Operate the necessary sequencing to enable the drive and using 1.18 to set the speed note the motor RPM displayed in 71.05 and the percentage torque demand displayed in 70.54, 0 – 1000 represents 0 – 100% torque demand.
5. Using the measured values of motor RPM and percentage torque demand set up the profiler table.
6. Re-enable the winder program
14.06 = 1
14.16 = 1 This will save the MD29 registers recently programmed and restart the Winder programme.

7.5.2 Inertia Compensation

The total inertia of a winder system is considered as two parts, the fixed inertia component which includes the inertia of the motor and the winder machinery and a variable component provided by the material being wound. In this system the fixed components are entered and stored in parameters and the variable component is continuously calculated from the dimensional data held in the software. It is therefore important that fairly accurate values are entered during set up and if varying widths of material are to be wound the width parameter should be updated to match the product. The inertia compensation function is illustrated below.

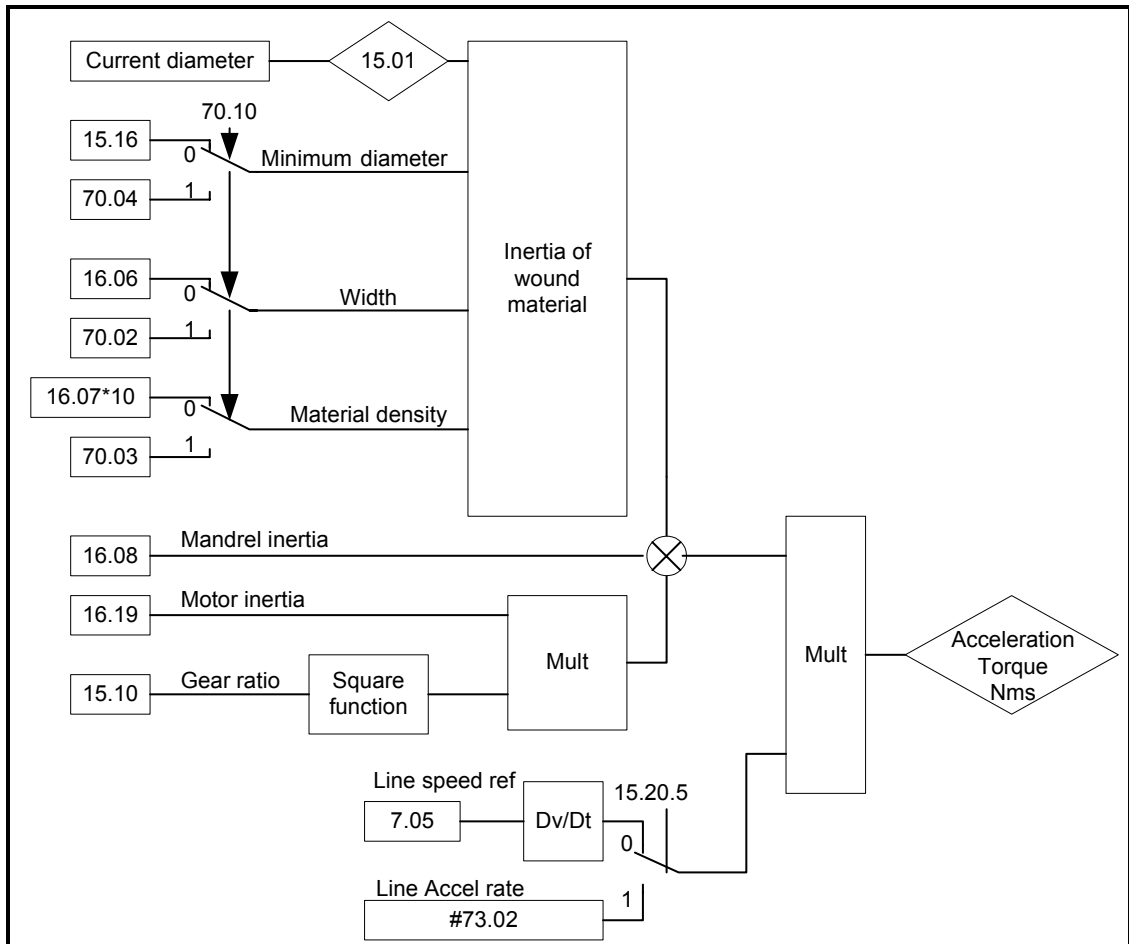

Alternative sources of acceleration rate are available; default selection 15.20.5 = 0, selects the output from a differentiator, which monitors rate of change of the line analog speed reference. Setting parameter 15.20.5 = 1 reads a value from parameter 73.02 which can be updated from an external source such as the suitably scaled currentDX output from an S Ramp function block generator in the master drive.

Scaling of this input signal should be arranged as follows:

$$\text{Parameter 73.02} = \frac{\text{Actual m/min/second} \times 16000}{\text{Maximum m/min}}$$

When a CTNet system is used then a cyclic data link may be set up to pass this signal to the winder from the master drive.

The externally sourced signal is preferred, as the output from the differentiator is invariably noisier. Adjusting its scan time using parameter 70.23 may optimise the output from the differentiator.

The acceleration rate is displayed in parameter 16.05 in metres per minute per second.

7.5.3 Flux Compensation

When field weakening is applied to a DC motor, the torque produced per amp of armature current is reduced in relation to the percentage reduction of flux. The winder application produces demands for torque which are in turn converted to demands for armature current, if the correct torque is to be produced under field weakened conditions then the armature current must be increased to compensate for the reduction in torque per amp.

This increase is provided by the flux compensation routine, if the speed is increased by a factor of 2 above base speed then to achieve the same final torque the armature current must be doubled. The flux compensation function generates a multiplier, which increases the armature current demand when the motor exceeds base speed. The multiplier is limited to a maximum value of 5, which is equivalent to the maximum field weakening range considered practical on a DC motor.

When operating in Back EMF mode the motor armature voltage used by the flux compensation routine is obtained from 1.05, in standard mode this value will be read directly from the value used to set up the field controller in 6.07

The flux compensation factor is generated using the expression

Flux compensation = $\text{MAX}((\text{Motor speed} / \text{Base Speed}), 1)$.

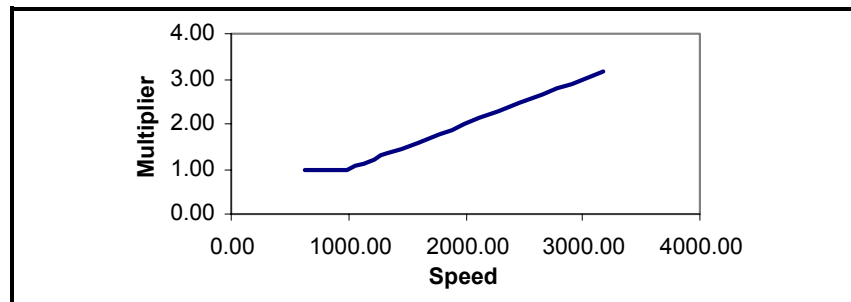

The diagram above shows the output from the flux compensation function for a motor with a base speed of 1000 RPM and a maximum speed of 3000 RPM.

7.6 Using the Field Current Profiler in Back EMF Mode.

(Selected when 15.20.7 = 1)

The field current profiling function should only be used when the application is to be operated in Back EMF mode. The user should be fully acquainted with this mode of operation,

When the application is used in Back EMF mode the operation of the field current regulator is changed from field weakening by armature voltage spill over to straightforward field current control. The reference for the field current is provided by a profiler which must be programmed by the user to generate the required field current / diameter relationship.

When operating in armature voltage spill over three parameters determine the maximum and minimum field current and the armature voltage at which field weakening will occur.

These are:

Armature voltage limit	06.07
Maximum field current	06.08
Minimum field current	06.10

When using the standard mode of operation these parameters should be set up in the normal manner.

Selecting the Back EMF mode of operation requires that these parameters be set up differently. Spill over must be inhibited by setting 6.07 to 1000 and 6.08 is used as the field current reference. Minimum field current 6.10 should be set to the lowest demand programmed into the profiler. This is performed by the application.

The diagram below indicates the manual set up of 6.07, 6.08 and 6.10 in standard mode and auto set up in Back EMF mode. Parameter 1.05 is used to set the motor base voltage to be used by the flux compensation function described above when Back EMF mode is selected.

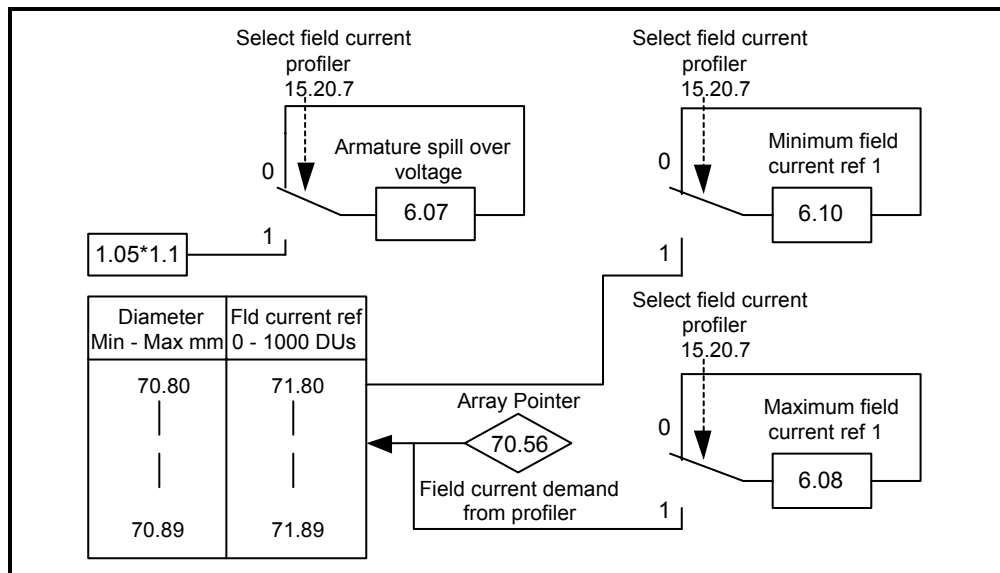

The field current profiler should be programmed to match the relationship between diameter and field current. Due to magnetic saturation effects in the motor this relationship is unlikely to be linear. Modern motors are designed to operate at relatively high flux densities and a range of 3:1 in flux may require a up to 10:1 variation in field current.

The curve below indicates the relationship between diameter and flux where field weakening is used to cover the first 100 to 300 mm of diameter and armature torque profiling at constant flux covers the larger diameters.

The continuous curve indicates the increased level of field current required to overcome saturation.

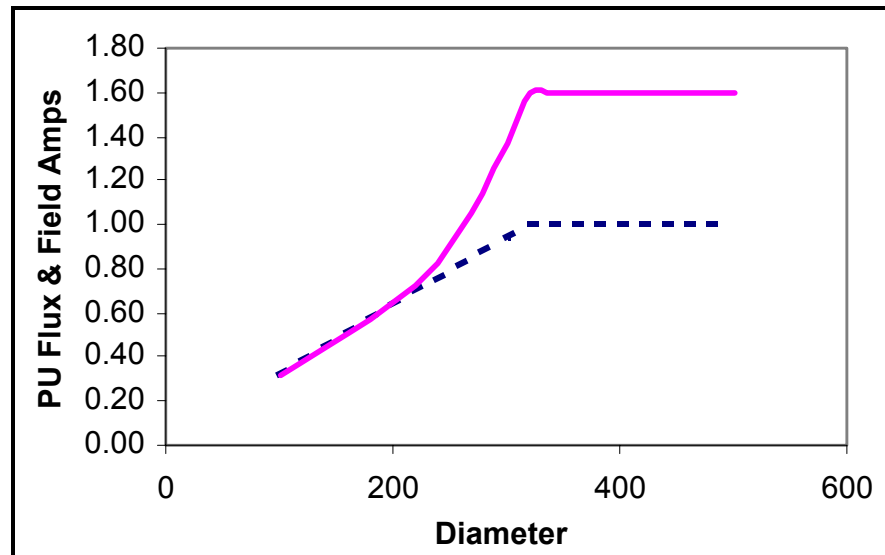

The second curve indicates the situation where field weakening is used over the whole of the diameter build up range. Where the field current forcing margin is greatly increased due to magnetic saturation.

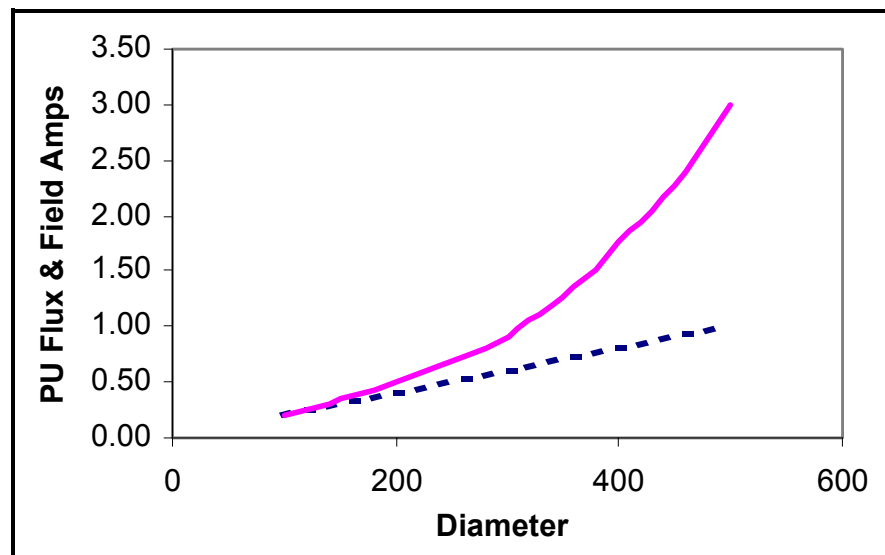

The field current profiler should be programmed to provide a function similar to the shape of the continuous lines in the diagrams above. 70.80 through to 70.89 store the values of diameter in millimetres with the corresponding field current demand values stored in 71.80 through to 71.89 where a range of 0 – 1000 should be used.

The field regulator should have previously been calibrated for the maximum field current required as described in the Mentor Manual.

To obtain the values required for the field current reference, data relating speed to field current is required. On request, the motor manufacturer may provide a set of test results plotting field current against speed at maximum voltage, as shown below.

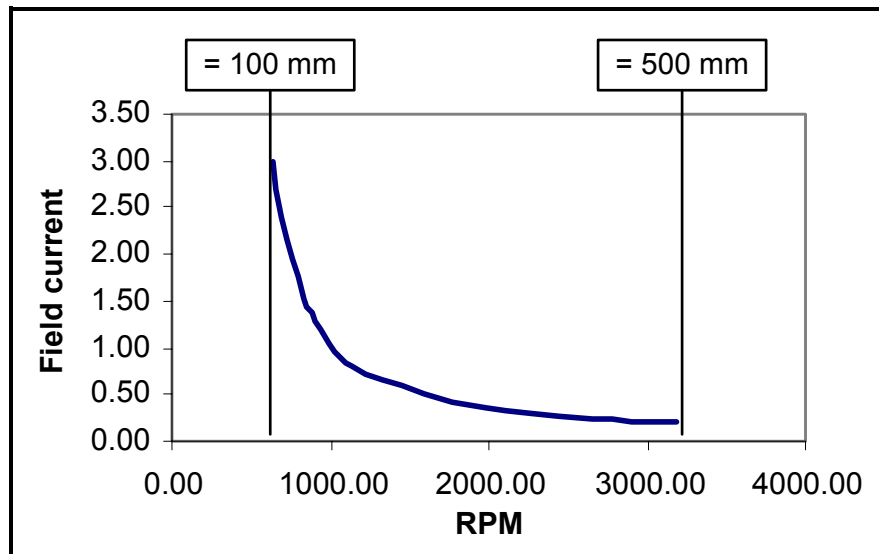

If this information is not available then the user must conduct a test to provide a similar set of results.

The simplest procedure is as follows:

Disable the application

Temporarily set the Mentor up to run under armature voltage feed back

Set 6.07 = 1000 to ensure that armature spill over cannot occur

Operate the external sequencing circuit to enable the drive

Increase the motor speed until the armature voltage reaches base voltage.

Adjust the field current until the motor is running at the speed equivalent to maximum line speed and maximum diameter. This will give the maximum field current value:

$$\text{RPM} = \frac{\text{Maximum line speed} * 1000 * \text{Gear ratio}}{\text{Pi} * \text{Maximum diameter (millimetres)}}$$

Gradually increase the motor speed by reducing the field current with regular spot checks on speed and field current. Note the values and ensure that the armature voltage does not change.

Continue until the speed for minimum diameter is reached, the speed calculated above multiplied by the diameter build up range. This will be the minimum field current.

Convert the speed readings to their equivalent diameter values and proceed to set up 70.80 - 70.89 and 71.80 - 71.89.

Save the table settings using #14.16 = 1

Reset the temporary set up and restart the application.

The resulting profile set up may look similar to the diagram below.

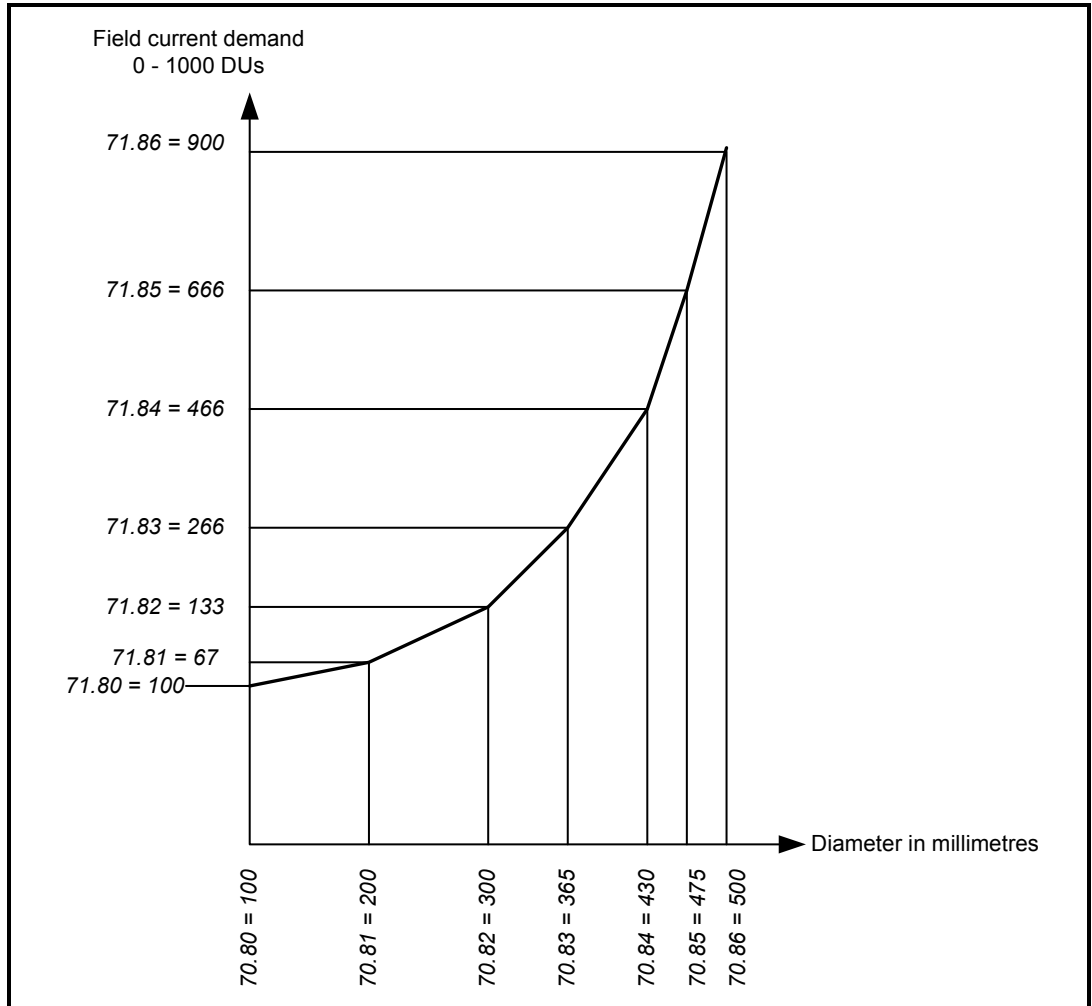

7.7 Speed Control functions

Several auxiliary functions associated with controlling the speed of the drive are necessary to ensure satisfactory operation as a winder. The software uses the value of line speed (MPM) and current diameter (mm) to predict the desired winder speed. This speed is then used as the reference speed for the drive, if a gearbox is fitted then the speed is modified to account for gear ratio (15.10).

In speed controlled applications this final motor speed is trimmed by the PID in relation to the position feedback signal obtained from the dancer or the tension feedback obtained from a load cell. In torque controlled applications this speed is used together with a speed offset value to provide the speed limit used by the drive when operating in torque mode.

Initial positioning of the dancer during start up in speed control mode is performed by a centring routine. This ensures that the dancer is correctly positioned before the PID control is enabled, reducing the possibility of large transients in dancer position during web take up on starting.

7.7.1 Speed Offset for Torque Control

In Torque control mode the Mentor remains in speed control but its speed reference is increased to cause it to try to over-speed, forcing it into current limit. To achieve this the Mentor requires a speed reference, which is marginally higher than the anticipated speed of the winder, where the speed reference is too low the drive will come out of current limit and revert to speed control. It is essential that the speed offset is set high enough to maintain the speed controller in saturation at all times during winding.

Tension and compensation torques are summed and used to determine the level of current limit thereby setting the current at the desired level.

An offset speed function generator combines the offset value (15.12 or Alternative 70.35) with the line speed reference to ensure that the final speed reference applied under torque control modes is correct under all conditions of winding and unwinding, see below. The speed offset is enabled when the Tension On bit parameter 15.23 is set to 1. The polarity of the speed offset is matched to the selection of wind or unwind and the torque demand as illustrated below.

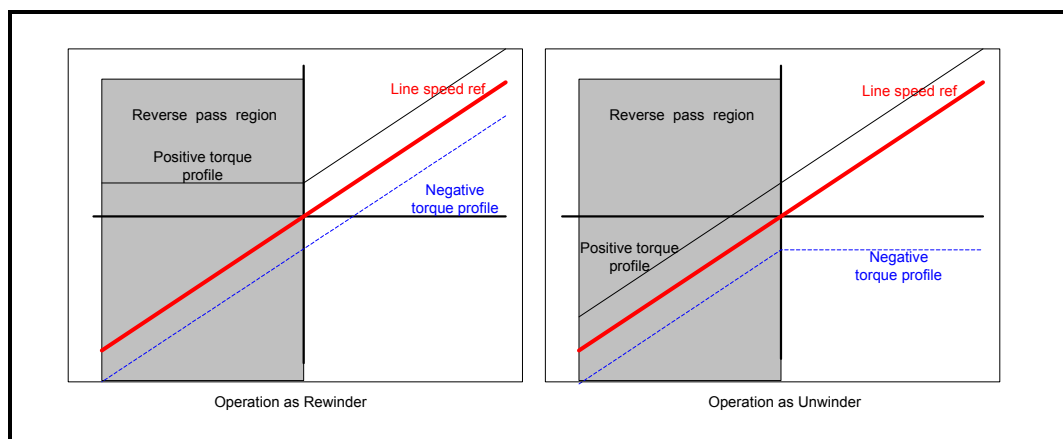

7.7.2 Dancer centring Routine

The dancer centring routine is a one shot operation, which occurs when the winder is selected to Tension On with the PID enable bit set, it is only active when operating the winder in Speed control mode. It's function is to ensure that the dancer is located within controllable limits before the PID controller becomes active. The PID action is inhibited internally until the centred flag has been set, at which point the centring routine is cancelled and the PID takes control. Further action by the centring routine is prevented until the centring flag has been reset which occurs when the Tension On bit is reset.

The centring routine provides a speed reference, which causes the winder to take up or pay out material and move the dancer into a predefined target area.

It is suggested that the PID enable should be set at all times when operating in this mode.

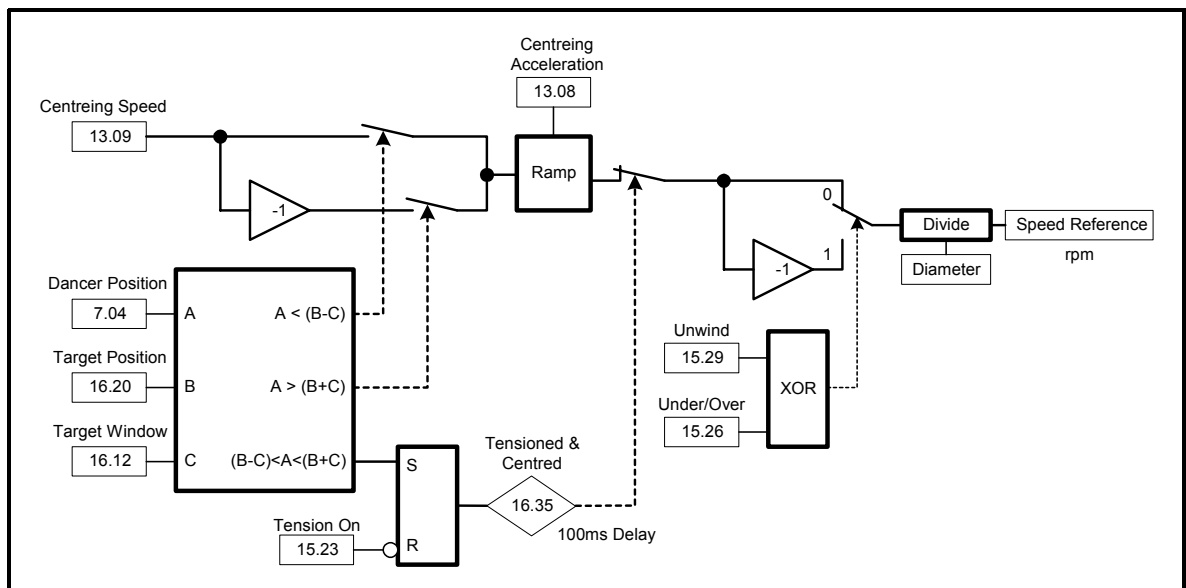

7.8 PID Control

PID controllers are provided for both Torque and Speed modes of operation. In torque mode, a load cell will normally provide the feedback signal, although in certain instances a dancer could be used. In speed mode the tension feedback may be provided from a dancer or a load cell. In both instances the output of the PID provides a trim to the final reference signal before it is passed to the drive. This trim will normally be very small as the actual required speed or torque references; will be accurately calculated by the software.

It is essential that the feedback signals are of the correct polarity and when used as a direct measurement of tension they must be correctly calibrated. The signals should be positive and arranged to increase in a positive direction with increasing tension/position. In the case of load cells they must be selected for the correct range of tension to be controlled and correctly calibrated with test loads applied at the correct entry and exit angles. Where dancer control is used if a potentiometer is to provide the measure of dancer position then this potentiometer should be of the plastic tracked variety and suitably mechanically robust. Mechanical end stops should be provided to prevent overrun of the potentiometer.

Differences in the effect of the PID between Rewind and Unwind installations are taken care of within the software.

In speed mode a low value of feedback to the PID, (negative error) results in an increase in speed of a drive operating as a rewind and a reduction in speed of a drive when operating as an unwind.

In torque mode a low tension feedback, (negative error) will result in an increase in re-winder torque (motoring) and a decrease in un-winder torque (braking).

7.8.1 Load Cell Calibration

Load cells may be used to provide direct measurement of material tension various configurations are used. The most common being two load cells located at each end of the tension measuring roll, their outputs being summed in the associated amplifier to produce a signal proportional to total tension. Other arrangements use split rolls with more load cells distributed along the length of the roll again their outputs being summed in the amplifier. Simple systems may have only one load cell mounted at one end of the roll, the other end being mounted in a flexible support operating as a hinge.

Whatever the mechanical arrangement load cells are always provided with a signal conditioning and summing amplifier which converts the millivolt signal from the cell to a usable voltage range usually 0 –10 Volts. An output calibration potentiometer is normally provided to adjust this output voltage to suit the installation. When using load cells ensure that they are specified for the range of material tension to be measured, various ranges are available from tens of Newtons up to thousands of Newtons. If the load cell range is too great compared with the tension it is to measure then the tension signal will have very poor resolution.

Where the load cell output range is less than 10 volts, parameter 7.19 may be used to scale the feed back to the required level.

To calibrate the load cell apply test weights equal to the anticipated maximum tension supported by ropes or webbing which has been threaded through the machine following the material path. The total weight applied should be equal to the maximum tension. The output calibration can then be set to provide a tension feedback signal monitored in parameter 71.06 is equal to maximum tension in Newtons.

1 kg = 9.81 Newtons 1 lb = 4.45 Newtons

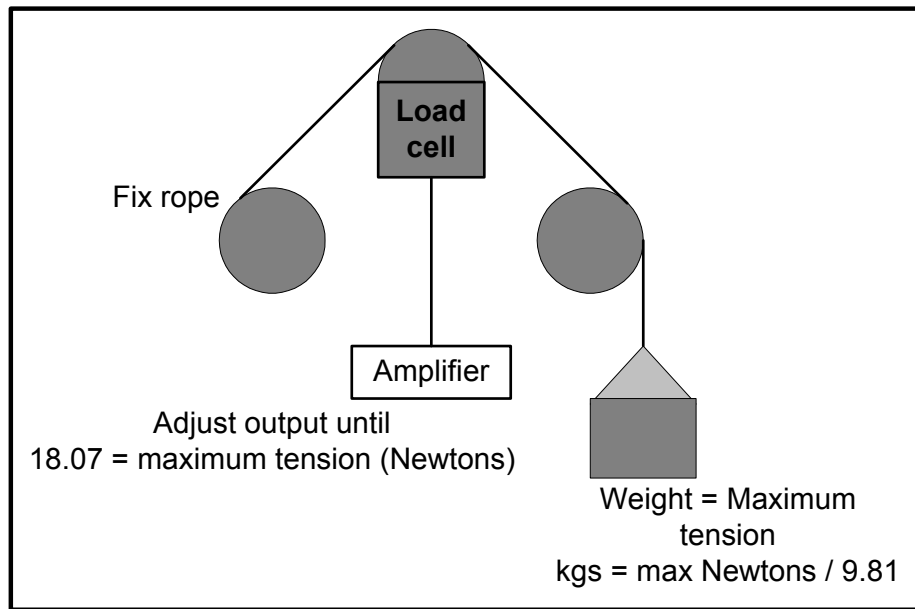

NOTE If the line speed is derived from serial communications (15.20.0=1) then the tension feedback is derived from terminal 3. This provides 12bit resolution instead of 10bit (terminal 7) and also a current signal 0/4-20ma signal to be selected if required. When using this input the line encoder reference must be deselected (70.27=0)
If the line speed is provided as an analog reference input via terminal 3 (15.20.0=0) then the tension feedback is derived from terminal 7.

7.8.2 Dancer calibration

The Dancer feedback signal should be directly proportional to dancer position, it should be arranged to produce 0 – 10 Volts to represent the full range of dancer travel.

Increasing voltage should correspond to increasing tension. The target position for the dancer can be set in parameter 16.20 which is multiplied internally by 4 giving an effective range of 0 - 1000. A 0 - 10 at 7.04 volt input span will also result in an internal range of 0 - 1000, setting 16.20 = 125 will therefore aim the dancer at mid position.

If the dancer mechanism has only limited voltage output range then the minimum and maximum extremes should be established and the target position set mid way between the minimum and maximum values.

The software has no provision for a negative excursion of the dancer feedback signal; any movement producing a negative signal will therefore be treated as zero.

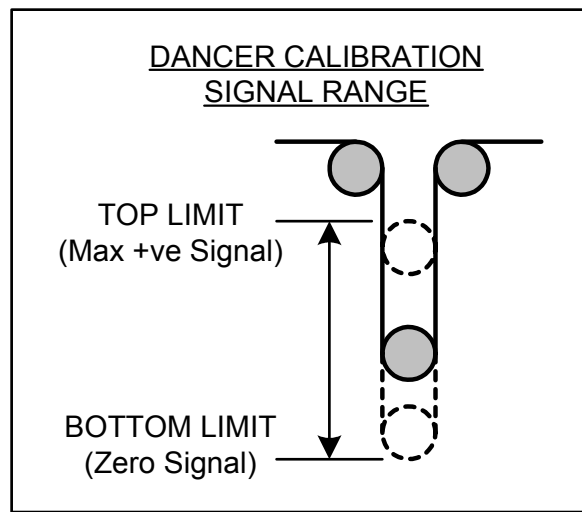

NOTE If the line speed is derived from serial communications (15.20.0=1) then the dancer position feedback is derived from terminal 3. This provides 12bit resolution instead of 10bit and also a current signal 0/4-20ma signal to be selected if required. When using this input the line encoder reference must be deselected (70.27=0).

7.8.3 PID Description

The PID (Proportional Integral Derivative) provides closed loop regulation to maintain process consistency and compensate for external disturbances. In winder applications it can be used to correct any non-linearity in the drive / motor torque generation function and reduce the tension errors caused by mechanical losses.

The PID gains etc are allocated to keypad accessible parameters, however if the available range of these parameters proves to be too restricted an alternative set based upon Menu 70 registers may be selected by setting 70.13 = 1.

70.13 is a group selector if set then all adjustments must be made using the menu 70 registers.

Configuration of the PID control is shown below.

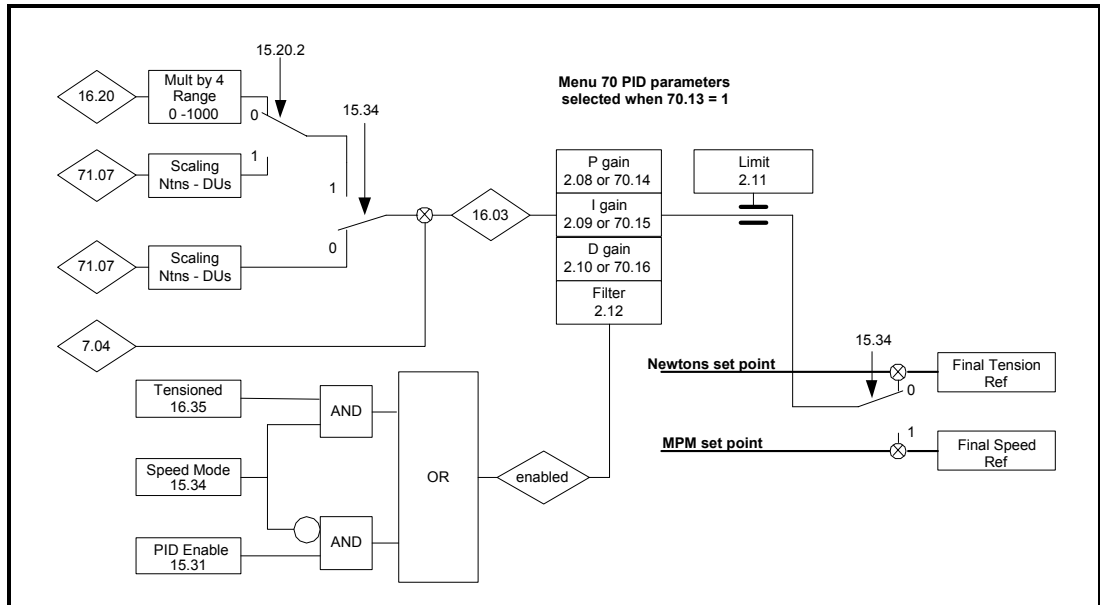

7.8.4 PID Operation (Torque Mode 15.34 = 0)

The Tension set point (71.07) derived from either the analog (7.01) or digital tension (70.08) reference combined with any taper tension effect. Represents the demanded value to be reached, and the Tension feedback (7.04) is the current, actual value being read from the tension transducer. The set point and the feedback are compared and the difference between these values represents the tension error (16.03). The tension error is used to perform a percentage trim on the final tension demand before it is converted to a torque demand for the motor to force the Tension feedback to equal the Tension set point. The response & the regulation accuracy of the process is dependant on the PID gain setting.

7.8.5 PID Operation (Speed Mode 15.34 = 1)

Using dancer feedback 15.20.2 = 0

The Dancer target (16.20*4) represents the position at which the dancer is to be maintained, and the Dancer feedback (7.04) is the current, actual position of the dancer. The set point and the feedback are compared and the difference between these values represents the dancer position error (16.03), which in turn is proportional to the tension error as determined by the dancer spring rate. The position error is used to perform a percentage trim on the final linear speed demand before it is converted to an angular speed demand (r/min) for the motor to force the Dancer feedback to equal the Dancer set point. The response & the regulation accuracy of the process is dependant on the PID gain setting.

Using Load cell feedback 15.20.2 = 1

Under this mode of operation the set point for the PID is derived from the tension set point and the feed back from a load cell, the PID is therefore providing a speed trim signal to control the tension directly. The tension error is used to perform a percentage trim on the final linear speed demand before it is converted to an angular speed demand (r/min) for the motor in order to maintain the load cell feedback signal equal to the tension set point. This arrangement an adjustable tension set point and also allows Taper tension to be included. The response & the regulation accuracy of the process is dependant on the PID gain setting.

7.8.6 PID Output Profiling

Often it is beneficial to provide allow increased corrective action from the PID at higher line speeds. This is due to the increased length of material on which the control system is having to control tension as the line speed increases. However if the range of correction is reduced in direct proportion to the line speed then inadequate correction may be available at reduced speed. Parameter 70.37 sets the percentage of maximum line speed below which the PID action will be held constant.

If 70.37 is set to 100 then the action available from the PID will be constant throughout the speed range.

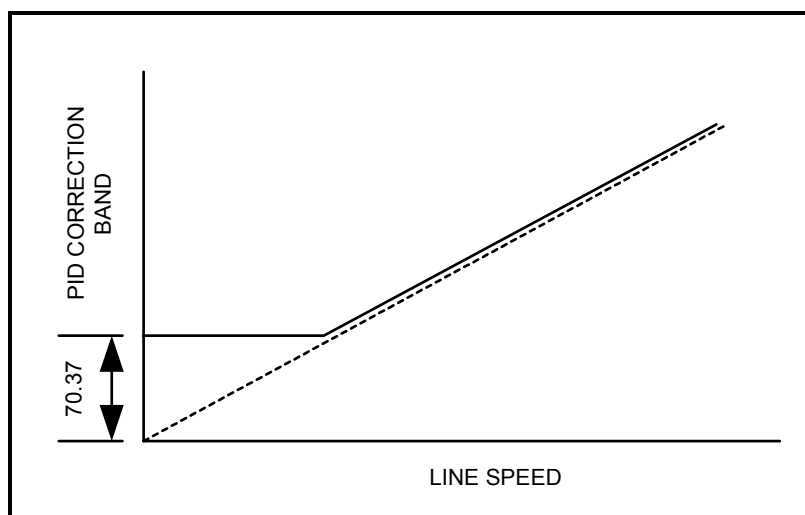

7.8.7 Proportional Gain Kp (2.08 or 70.14)

The Proportional gain is the instantaneous amplification factor that is applied to the process error.

$$P_{out} = K_p \cdot \varepsilon$$

The Proportional term must have an error to produce an output. The magnitude of the output is dependant on the magnitude of the error and the amount of proportional gain. For an error of 1, and a Proportional gain of 1000, the output of the P term will be 1. The Gain is set as a fixed-point integer.

7.8.8 Integral Gain Ki (2.09 or 70.15)

The integral gain is amplification factor of the error over time.

$$I_{out} = (K_i \cdot \int \varepsilon \cdot dt) / 10$$

The integral term accumulates any error over time to help reduce any offset or long-term errors such as frictional losses or discontinuities drive torque linearity. Ki is a multiplication co-efficient of the integrated value.

For a constant error of 1, and an Integral gain of 10, the output of the I term will reach 1 after 1 second. The Gain is set as a fixed-point integer.

7.8.9 Differential Gain Kd (2.10 or 70.16)

The derivative gain is amplification factor of the rate of change of error.

$$D_{out} = (K_d \cdot \delta\varepsilon/\delta t) / 10$$

The Differential term is the rate of change of the error multiplied by the Kp co-efficient. This is responsive during transient conditions; therefore it is zero during steady state condition. It is useful to reduce the overshoot during large disturbances. The differential gain is rarely used in most applications as it will amplify any unwanted noise to the system and can cause instability.

For a constant rate of change of error of 1 count per second and a differential gain of 10, the output of the D term will be 1. The Gain is set as a fixed-point integer.

PID Output

The PID output is the summation of all the terms above as follows:

$$PID_{output} = \left[\begin{array}{c} \text{Max Limit} \\ \left(\frac{K_p \cdot \text{error}}{1000} \right) + \left(\frac{K_i}{10} \cdot \int \text{error} \cdot dt \right) + \left(\frac{K_d}{10} \cdot \frac{d\text{error}}{dt} \right) \\ \text{Min Limit} \end{array} \right]$$

The PID output is clamped between symmetrical limits, which are the Min and Max trim ranges by which the torque or speed can be adjusted set 2.11. These limits define a working area within the PID. If the output crosses one of the limits, the PID output will be clamped until the output returns within these limits. The limits will also stop the integrator accumulating until the integrated error is back in the working range.

7.9 Reversing Mill Applications

Reversing Mill applications require the winder drives to alternately operate as un-coilers and coilers, setting up this software to operate in this manner is simple.

The Coiling and Uncoiling system torque polarities must conform to the following truth table.

Line Forward (+ve speed reference)

Mode	Tension	Losses	Inertia Comp
Coiler	+ve	+ve	+ve/-ve
Un-coiler	-ve	+ve	+ve/-ve

Line Reverse (-ve speed reference)

Mode	Tension	Losses	Inertia Comp
Coiler	+ve	-ve	-ve/+ve
Un-coiler	-ve	-ve	-ve/+ve

When applying this package to reversing applications remember that the tension polarity does not change when the line direction reverses. Coiler and Un-coiler direction will be determined by the material being wound the software will automatically determine the correct polarity for the loss and inertia compensation signals from the polarity of the line speed and acceleration rate signals received from the master drive.

Example – Setting up a reversing mill configuration

When configuring a reversing system with Unwind and Rewind, define line forward as the direction from De-Coiler to Re-Coiler and set Unwind mode (15.29 = 1) for the De-Coiler only. To run the system, simply set the forward run command Term on both drives. A Forward pass is defined as running from De-Coiler to Coiler with a positive, line speed reference signal. When the line runs in the opposite direction a negative line speed reference signal must be provided.

The system will automatically take care of all internal torque polarity selections. Tension polarities will be set to pull away from the central nip. Inertia compensation and loss compensation torque polarities will be determined by the polarity of the line speed reference signal.

7.10 Turret Winder Features

Several features are provided which are specific to the requirements of Turret Winders and Flying Splice applications. Most turret winders are designed to the same basic set of principles. The turret rotates to allow either of two rolls of material to be processed, winding or unwinding. A mechanism is provided to allow the material from an incoming roll to be spliced onto the end of the material from an expiring roll at the unwind or conversely from a full roll to an empty mandrel at the rewind. This ensures that the machine can run continuously at normal production speeds, with no necessity to stop and start for roll changes. Splicing can be achieved satisfactorily on machines running up to approximately 2000 metres per minute.

Each spindle on the turret assembly is equipped with a winder motor and drive control system, it is not possible to share spindle drives if the spindle drive is used to accelerate the incoming roll whilst the expiring roll is running.

Some systems provide a separate surface belt drive to accelerate the incoming roll, in which case the winder spindle motors may share a common drive controller with associated changeover contactors etc. This arrangement can often be found on News Press reelstands.

7.10.1 Torque Memory Function

Speed Mode

During a changeover, tension feed back from the load cell or dancer must be transferred from the expiring roll to the incoming roll, to avoid problems during this period the expiring roll drive can be switched from speed control with PID trim to torque control running at a level of torque measured just prior to the start of the changeover process. Using this feature avoids difficulties due to disturbances affecting the load cell being fed into the winder control system.

On completion of a changeover the drive will normally be returned to speed control and ramped to zero speed.

Torque Mode

Torque memory is also available when operating in torque mode, if problems occur during turret indexing or roll transfers then enabling torque memory will set the torque reference at the previously active value of its tension component and hold it until torque memory is disabled.

The torque boost functions described below are not affected and may be used with or without torque memory being enabled.

The torque memory mode is enabled by 16.21.

7.10.2 Index Torque Boost Function

Whilst a turret is being indexed the material tension may suffer a disturbance due to the change in attack angle of the material and the effective change in material length as the turret rotates. A facility is provided within the software to adjust the running torque to compensate for this effect.

The value is set as a percentage of actual torque (tension). This function operates on the tension set point when operating in torque mode or on the memorised torque value when using torque memory.

Index torque boost is enabled by 16.23 and the value is set by 70.24.

7.10.3 Speed Boost Function

Once the new roll is in position then it must be accelerated so that its peripheral speed matches the line speed, this is achieved by presetting the correct diameter into the drive and provided a line speed reference signal. The incoming diameter can be input by the operator using an MMI or similar device, or it can be read from an ultrasonic scanning device. Often in order to achieve 100% repeatable splicing on an unwind it can be advantageous to provide a slight over speed of the incoming material, a speed boost feature is provided to perform this function.

Speed boost is enabled by 16.24 and the value is set in 70.26. The value is calibrated on MPM and is limited to a maximum of 10% of maximum line speed.

7.10.4 At Line Speed Function

Splicing applications on turret winders require a signal to confirm that the winder peripheral speed has achieved to correct value to allow a splice or roll change to commence. The acceptance window for this signal is set in parameter 70.42 in 0.1 mpm or 0.1 fpm. The target line speed is taken as actual line speed plus speed boost, once the actual peripheral speed of the winder is within the window of this level the at line speed bit, bit 11 of the Status word will be enabled.

7.10.5 Lay On Roll Torque Boost Function

The final operation in the changeover sequence the web being deflected towards the surface of the new roll in readiness for the splice. A roll generally termed the Lay On roll performs this function. The Lay On roll is not driven and therefore presents an extra drag on the material possibly resulting in a tension disturbance.

Lay On roll torque (tension) boost is enabled by 16.28 and the value set in 70.25. The value is set as a percentage of maximum tension.

7.11 Communications Watchdog

The Watchdog is used to provide a mechanism to ensure the safe operation when movement is being controlled from a remote device. The watchdog checks that the remote device is online and capable of both sending and receiving data. This is done by sending a clock signal to the remote device, which responds by resending the same clock signal back, the returned signal is then monitored to make sure that the received data is of similar clock period to the sent data.

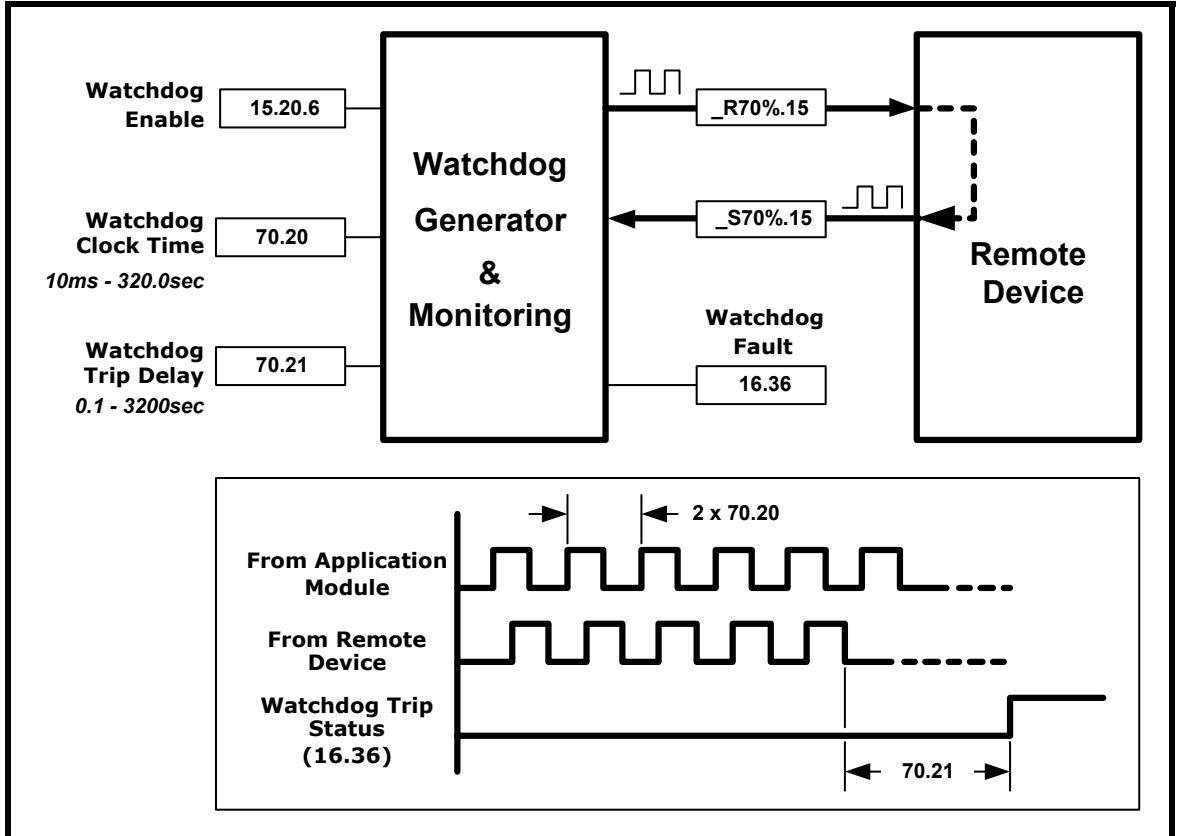

8 Parameter Descriptions

8.1 Mentor Standard Parameters

The following parameters can affect this application and should be set up or checked for valid data. A short description of the parameter is given, but for more information please refer to the Mentor manual.

NOTE Important - Due to the limited availability of parameters within the Mentor, certain standard parameters have been re-assigned to non standard functions. The re-assigned parameters are described in section 8.2.

Manual Description	CT Part Number
User Guide for Mentor II	0410 - 0009

8.1.1 Menu 1

01.01	Level of reference selected
Range:	±1000
Units:	DUs

Indication of the reference being used by the drive is given for system set up and fault finding.

01.06	Maximum Speed Clamp
Range:	0-1000
Units:	DUs

Defines drive absolute maximum speed reference suggested starting value 1000.

The Application software controls this parameter.

01.07	Minimum Forward Speed Clamp
Range:	0-1000
Units:	DUs
Default settings:	0

Defines drive absolute minimum speed reference. Disabled if bi-polar 1.10 = 1 is selected.

01.08	Minimum Reverse Speed Clamp
Range:	0-1000
Units:	DUs
Default settings:	0

Defines drive absolute minimum speed reference. Disabled if bi-polar 1.10 = 1 is selected.

The Application software controls this parameter, setting = 1.

01.20 Preset Speed reference 3	
Range:	±1000
Units:	DUs
Default settings:	0.0

This is the speed reference produced by the application software within the MD29. Selected when 1.14 = 0 and 1.15 = 1.

01.21 Preset Speed reference 4	
Range:	±1000
Units:	DUs
Default settings:	0.0

This is the speed reference produced by the application software within the MD29. Selected when 1.14 = 1 and 1.15 = 1.

8.1.2 Menu 2

02.01 Post ramp speed reference	
Range:	±1000.0
Units:	DUs

This is the speed reference after the ramps. The range of this parameter is restricted so that it cannot be larger than the range set by Pr 01.06 (maximum speed clamp) and Pr 01.07 (minimum speed clamp).

02.02 Ramp enable	
Range:	0-1

This parameter is controlled by the application.

The Application software controls this parameter, setting 1.

02.04 Forward Acceleration Rate	
Range:	0 - 1999
Units:	Tenths of seconds
Default	50

This sets the Acceleration rate for Post ramp reference to ramp up to Pre ramp reference, when Post ramp reference is less than Pre-ramp reference.

02.05 Forward Deceleration Rate	
Range:	0 - 1999
Units:	Tenths of seconds
Default	50

This sets the Deceleration rate for Post ramp reference to ramp down to Pre ramp reference, when Post ramp reference is greater than Pre-ramp reference.

02.06 Reverse Acceleration Rate	
Range:	0 - 1999
Units:	Tenths of seconds
Default	50

This sets the Acceleration rate for Post ramp reference to ramp up to Pre ramp reference, when Post ramp reference is less than Pre-ramp reference.

02.07 Reverse Deceleration Rate	
Range:	0 - 1999
Units:	Tenths of seconds
Default	50

This sets the Deceleration rate for Post ramp reference to ramp down to Pre ramp reference, when Post ramp reference is greater than Pre-ramp reference.

8.1.3 Menu 3

03.12	Select encoder or Tacho feed back
Range:	0 - 1

Set to 1 if an encoder is to be used for the speed feed back signal.

If a tacho is used then see 15.50 15.51 for speed calibration.

03.13	Select armature voltage feed back
Range:	0 - 1

Set to 0 armature voltage feed back should not be used.

03.15	Maximum armature voltage
Range:	0 - 1000
Units	Volts
Default	600

Set to a safe value above the maximum armature voltage, the voltage should only be limited by the effect of the field controller.

8.1.4 Menu 4

04.01 Motor current demand	
Range:	0 - 1000
Units:	DUs

This parameter indicates the percentage level of current from the drive.

04.04 Symmetrical Current Limit	
Range:	0 to 100%
Units:	DUs
Default settings:	1000

This sets the current as a percentage of drive burdened current.

The Application software controls this parameter.

04.05 Forward Current Limit	
Range:	0 to 100%
Units:	DUs
Default settings:	1000

This sets the forward current as a percentage of drive burdened current.

This parameter together with 4.06 should be used to set the operational current limit values, the symmetrical current limit 4.04 is controlled by the application. Forward and reverse current limit should be used to determine the emergency stop braking current applied when terminal 21 is disabled.

04.06 Reverse Current Limit	
Range:	0 to 100%
Units:	DUs
Default settings:	1000

This sets the reverse current as a percentage of drive burdened current.

This parameter together with 4.05 should be used to set the operational current limit values, the symmetrical current limit 4.04 is controlled by the application. Forward and reverse current limit should be used to determine the emergency stop braking current applied when terminal 21 is disabled.

04.11 Current Offset Selector	
Range:	0 - 1
Default settings:	0

Setting this parameter to 1 introduces the current offset from parameter 4.09.

Set to 1 if feed forward compensation torque is required, (Loss & Inertia compensation).

8.1.5 Menu 5

05.01 Motor Current	
Range:	0 - 1000
Units:	DUs

This is the indication of Motor current.

05.17 Inhibit firing	
Range:	0 – 1

Set to 1 during the initialisation stage of the application. Cleared to 0 after initialisation.
The Application software controls this parameter.

05.18 Stand still Logic	
Range:	0 - 1

When set to 1 disables motor torque at stand still.

The Application software controls this parameter, setting 0.

8.1.6 Menu 6

06.07 Field controller Armature voltage spill over set point	
Range:	0 - 1000
Default settings:	1000

Defines the armature voltage equivalent to base speed.

Application Recommended setting

Constant torque = 1000

Constant Power = Motor base volts as set in 01.05

06.08 Field Current No 1	
Coding	RW, Uni, P
Range:	0 - 4
Default settings:	4

This parameter is used as the field current reference when operating the application as a Back EMF winder.

The Application software controls this parameter.

8.1.7 Menus 7

These parameters indicate the status of the Analogue Inputs, the analogue inputs are read directly by the application and their functions are pre – defined. No attempt should therefore be made to assign these inputs.

07.01 Analogue Input 1	
Input terminal	4
Range	0 - 1000

Used by the Application as the analogue tension set point.

07.02 Analogue Input 2	
Input terminal	5
Range	0 - 1000
Default settings:	0

Used by the Application as the analogue input taper set point.

07.03 Analogue Input 3	
Input terminal	6
Range	0 - 1000

Used by the Application as the analogue input diameter set point.

07.04 Analogue Input 4	
Input terminal	5
Range	0 - 1000

Used by the Application as analogue input of dancer / load cell.

07.05 Analogue Input 5	
Input terminal	3
Range	0 - 1000

Used by the Application as:

15.20.0 =1: Analogue input for line speed

15.20.0 =1: Analogue input for Tension/Dancer feedback

07.19 Analogue Input 4 Scaler	
Range	0 – 1999
Default settings:	1000

Provides a means of scaling the load cell feed back

$$\text{Scaling factor} = \frac{07.19}{1000}$$

Used by the Application to scale the tension feed back.

07.20	Analogue Input 5 Scaler
Range	0 - 1999
Default settings:	1000

Provides a means of scaling the speed reference.

$$\text{Scaling factor} = \frac{07.20}{1000}$$

Used by the Application as a draught compensation factor.

NOTE Analogue inputs are assigned within the application. The analogue input pointer parameters 07.11 through 07.15 are set to zero by the application and should not be used.

8.1.8 Menu 8

The following parameters may be used to monitor and configure the digital control functions. The standard Mentor movement function inputs 08.02 to 08.05 remain dedicated to their original functions. The programmable inputs may be assigned by the user to fulfil the requirements of the particular installation.

08.01	Digital I/O channel F1 State indicator
Terminal	21
Range	0 - 1
Function	Run permit

Used by the Application to provide the digital input run permit.

08.02	Digital I/O channel F2 State indicator
Terminal	22
Range	0 - 1
Function	Inch reverse

Used by the Application to provide the digital input inch reverse.

08.03	Digital I/O channel F3 State indicator
Terminal	23
Range	0 - 1
Function	Inch forward

Used by the Application to provide the digital input inch forward.

08.04	Digital I/O channel F4 State indicator
Terminal	24
Range	0 - 1
Function	Run reverse

This parameter may be assigned by the user.

08.05 Digital I/O channel F5 State indicator	
Terminal	25
Range	0 - 1
Function	Run forward

Used by the Application to provide the digital input line run.

08.06 Digital I/O channel F6 State indicator	
Terminal	26
Range	0 - 1
Function	Programmable

This parameter may be assigned by the user.

08.07 Digital I/O channel F7 State indicator	
Terminal	27
Range	0 - 1
Function	Programmable

This parameter may be assigned by the user.

08.08 Digital I/O channel F8 State indicator	
Terminal	28
Range	0 - 1
Function	Programmable

This parameter may be assigned by the user.

08.09 Digital I/O channel F9 State indicator	
Terminal	29
Range	0 - 1
Function	Programmable

This parameter may be assigned by the user.

08.10 Digital I/O channel F10 State indicator	
Terminal	30
Range	0 - 1
Function	Programmable

This parameter may be assigned by the user.

08.16	Digital I/O channel F6 Destination parameter
Range	0 - 1999
Function	Assigns the destination address of terminal 26

This parameter may be assigned by the user.

08.17	Digital I/O channel F7 Destination parameter
Range	0 - 1999
Function	Assigns the destination address of terminal 27

This parameter may be assigned by the user.

08.18	Digital I/O channel F8 Destination parameter
Range	0 - 1999
Function	Assigns the destination address of terminal 28

This parameter may be assigned by the user.

08.19	Digital I/O channel F9 Destination parameter
Range	0 - 1999
Function	Assigns the destination address of terminal 29

This parameter may be assigned by the user.

08.20	Digital I/O channel F10 Destination parameter
Range	0 - 1999
Function	Assigns the destination address of terminal 30

This parameter may be assigned by the user.

8.1.9 Menu 11

11.11 Drive module Serial comms. address	
Range:	0 - 99
Default settings:	001

Used in ANSI comms to define the unique address for the drive. Any number in the permitted range 0 to 99. Defines the unique address of the drive when several are connected to a common serial bus.

11.12 Drive module Serial comms. Baud Rate	
Range:	0 - 1
Default settings:	0

Determines the baud rate:

- 0 4800 Baud
- 1 9600 Baud

11.13 Drive module Serial comms. mode	
Range:	1 - 4
Default settings:	001

Defines the mode of operation of the serial port:

- ANSI 1
- Out put variable defined by 11.19 2
- Input to variable defined by 11.19 3
- Wide integer driver 4

11.14 Country code	
Range:	0 - 255
Default settings:	44

Used by optional display.

11.15 Drive Processor Software version	
Range:	0 - 255
Default settings:	0

11.16 MD29 Processor Software version	
Range:	0 - 255
Default settings:	0

11.19	Serial programmable source
Range:	0 - 1999
Default settings:	0

Defines the input or output parameter when serial comms mode 2 or 3 is selected, see 11.13.

8.1.10 Menu 13

13.10	Position Loop Enable
Range:	0 - 1
Default settings:	0

Enables the internal position loop, inhibited by the application to allow use of Menu 13 parameters by the application.

Set to zero by the Application to inhibit position loop.

13.12	Field Bus Contactor Enable
Range:	0 - 1
Default settings:	0

13.12 echoes the state of control word 2 bit 10 (73.70.10) this allows the drive contactor or some other device to be switched using a digital drive output under direct control of a PLC. The user must select and programme a digital output to this parameter.

Controlled by the Application.

8.1.11 Menu 14

MD29 set up parameters refer to the MD29 user manual for relevant parameter information.

Manual Description	CT Part Number
User Guide MD29	0400 - 0027

8.2 Mentor Non-Standard Parameters

Parameters listed in this section have been re-assigned in this application to perform functions which differ from the descriptions provided in the manual.

01.05 Motor Base Voltage	
Normal assignment	Inch speed
Units	Volts
Range:	0 - 1000
Default settings:	050

Should be set to the motor nameplate voltage at base speed, for a constant torque motor this will be maximum speed, for a constant power motor this will be the voltage at which field weakening should commence.

01.17 Maximum Diameter	
Coding	RW
Range:	Min Diameter [15.16] – 1000
Units:	Millimetres 0.1inches

Sets the maximum limit of the diameter range and should be set equal to the maximum diameter to be handled.

An alternative wide range maximum diameter parameter 70.05 is selected when 70.10 = 1.

01.19 Preset diameter value 2	
Coding	RW,
Range:	Min and Max diameter [15.16-1.17]
Units:	Millimetres 0.1inches

The new diameter to which the diameter calculator will be set on operation of parameter 15.28 is entered into this parameter. This parameter is selected as the preset value source when parameter 15.22 = 1 and 15.30 = 1. If parameter 15.22= 0, the preset value is obtained via parameter 7.03 (Terminal 6) analogue input. The resulting value is displayed in parameters 15.02 / 71.02.

02.08 PID P Gain	
Normal assignment	Group 2 ramp accel time
Coding	RW
Range:	0 - 1999
Units:	0.001Kp

Sets the gain of the P term when using the PID to provide closed loop tension control. A value of 1000 gives unity gain.

An alternative full range P term parameter 70.14 is selected when 70.13 = 1

02.09 PID Integral Gain	
Normal assignment	Group 2 ramp decel time
Coding	RW
Range:	0 - 1999
Units:	0.1Ki.sec

Sets the gain of the I term when using the PID to provide closed loop tension control. An alternative full range I term parameter 70.15 is selected when 70.13 = 1.

02.10 PID D gain	
Normal assignment	Group 2 ramp accel time
Units	PU
Range:	0 - 1999
Units:	0.1Ki.sec

Sets the D term gain value for the PID controller, an alternative wider range parameter 70.16 is selected if 70.13 = 1.

02.11 PID Output Limit		
Normal assignment	Group 2 ramp decel time	
Coding	RW	
Range:	0 - 1999	
Units:	Speed Mode: cm/min Torque Mode: 0.1%	Speed Mode: 0.01ft/min Torque Mode: 0.1%

Sets the maximum effective trim available from the PID in closed loop mode.

02.12 PID Filter term	
Normal assignment	Inch Ramp rate
Units	PU
Range:	0 - 1999
Default settings:	100

Sets the P term gain value for the PID controller, an alternative wider

04.11 Select compensation	
Coding	RW, Bit

Selects the Inertia and Friction compensation torque as a Torque offset added to the final torque demand when set. This can be used in Speed and torque modes.

07.01 Tension Set Point (Analogue)	
Coding	RO
Range:	0 - 1000
Units:	Per Unit
Terminal	4

This parameter provides the tension set point when using an analogue input; it is scaled internally by the maximum tension value to produce an internal value in Newtons. For digital set point see parameter 70.08.

07.02 Taper Set Point (Analogue)	
Coding	RO
Range:	0 - 1000
Units:	Per Unit
Terminal	5

This parameter provides the taper set point when using an analogue input. The value is internally scaled to 0 – 100%. For digital set point see parameter 70.09.

07.03 Preset Diameter (Analogue)	
Coding	RO
Range:	1 - 1000
Units:	Per Unit
Terminal	6

This parameter provides the preset diameter set point when using an analogue input. The value is internally scaled from the minimum and maximum diameter values such that 0 – 1000 represents minimum to maximum diameter. A diameter sensing device should be set to give zero at minimum diameter and 10 volts at maximum diameter.

Analogue diameter set point is selected when 15.22 = 0.

For digital Preset set point and internal derived diameter calculation see parameters 15.22 & 15.30.

07.04 Load Cell / Dancer Feed Back (Analogue)	
Coding	RO
Range:	0 – 1000
Units:	Per Unit
Terminal	7

The tension feedback signal must always be connected to terminal 7.

07.05 Line Speed Reference (Analogue)	
Coding	RO
Range:	0 – 1000
Units:	Per Unit
Terminal	3

This parameter provides the line speed set point when using an analogue input. When using an analogue line speed reference signal, the software will determine acceleration rates. See parameters 15.20.5 and 70.23.

07.20 Slip Factor	
Coding	RW
Range:	100 – 2000
Units:	0.001%

The line speed reference signal is multiplied by this parameter and divided by 1000. Allowing a slip factor to be introduced to compensate for differences between nip speed and material speed at the master drive.

08.02 Inch Reverse Command Bit	
Coding	RO, Bit
Terminal	22

Setting this input will cause the drive to run at thread speed in reverse direction.

Inch is only active when not in tension mode (15.23=0) and any other command is inactive (08.03 = 0 or 08.05=0).

08.03 Inch Forward Command Bit	
Coding	RO, Bit
Terminal	23

Setting this input will cause the drive to run at thread speed in forward direction.

Inch is only active when not in tension mode (15.23=0) and any other command is inactive (08.02 = 0 or 08.05=0).

08.05 Run Command Bit	
Coding	RO, Bit
Terminal	25

Setting this input will cause the drive to run. Direction will be determined by the polarity of the line speed reference signal, normally positive.

Speed reference is derived from the Line speed.

Activating the run command when tension ON is not energised (15.23 = 0) will cause the winder to follow the line speed reference, if tension ON is activated (15.23 = 1) enabling run will transfer the tension reference value from stall to run value.

13.08 Centring acceleration rate	
Normal assignment	Posn loop gain
Units	Cms/min/sec ins/min/sec
Range:	0 - 255
Default settings:	0

This defines the acceleration rate used when centring the dancer. Ensure this value is not set too low as oscillations may occur if the centring window (16.12) is set too narrow.

13.09 Centring speed	
Normal assignment	Posn loop limit
Units	Metres per minute Feet per minute
Range:	0 - 255
Default settings:	0

This parameter sets the maximum speed at which the dancer will be centred. If the set value exceeds the line maximum speed then the lower value will be used.

13.12 Main Contactor Control Bit From Serial Comms	
Normal assignment	Reference Source
Units	Bit
Default settings:	0

This parameter can be used to control the main contactor from serial communications. One of the mentor's digital outputs can be assign to this parameter to operate the main contactor via a pilot relay. This parameter is controlled directly from Bit 10 of the Control word (Parameter 73.70)

13.14 Encoder PPR	
Normal assignment	Precision speed reference (16bit)
Units	PU
Range:	0 - 60000
Default settings:	0

When using an encoder feed back the PPR of the encoder should be entered into this parameter.

NOTE This is a 16 bit "wide" parameter, the drive display does not show the lowest significant digit, 10 key presses are required for a change in the right hand digit of the display (10s).

Example for 1024 PPR encoder

Using the keypad

Increment until 1024 is displayed, the value in 13.14 will be between 10240 and 10249 this is reduced to 1024 by the software.

When inputting via serial communications write 10240 to 13.14.

8.3 Application Parameters

8.3.1 Menu 15

15.01 Actual Radius		
Coding	RO (Limited to 1999)	
Range:	Min and Max diameter [15.16-01.17]	
Units:	Millimetres	0.1inches

Indicates the current diameter.

A full range display of diameter is available in 71.01

15.02 Preset Radius		
Coding	RO (Limited to 1999)	
Range:	Min and Max diameter [15.16-01.17]	
Units:	Millimetres	0.1inches

Displays the value of the diameter to be used as the preset value.

A full range display of preset diameter is available in 71.02

15.03 Percentage Final Tension Demand	
Coding	RO
Range:	0 - 1000
Units:	0 – 10 volts on analogue output

Indicates the required level of tension demanded by the system after taper tension has been applied as a per unit value. This value may be output via an analogue channel to set the loading of a dancer system, possibly in conjunction with an E/P converter.

15.04 Line Speed Indication for MMI		
Coding	RO (Limited to 1999)	
Range:	0 – Max m/min (16.09)	
Units:	m/min	ft/min

Displays the actual line speed in Engineering Units.

A full range display of line speed is available in 71.03

15.05 Winder Speed	
Coding	RO (Limited to 1999)
Range:	0 - 1999
Units:	r/min

Indicates the actual speed of the winder shaft.

15.06 Motor Base Speed	
Coding	RW
Range:	1 – 1999
Units:	r/min

Used to calibrate the winder software to the motor.

15.07 Motor Base Power	
Coding	RW
Range:	1 – 1999
Units:	kWatts hp

Used to calibrate the winder software to the motor. Enter to the nearest kWatt, adjustments for mid kWatt values on low power systems may be made in the motor current 15.08.

15.08 Motor Current	
Coding	RW
Range:	1 – 1999
Units:	Amps

Used to calibrate the winder software to the motor. Enter the motor current to produce base kWatts at base speed.

15.09 Drive current	
Coding	RW
Range:	1 – 1999
Units:	Amps

Used to calibrate the winder software to the drive. Enter the current produced for a demand of 1000 Dus. Select the burden resistor to match the winder current requirements. When using torque mode ignore the requirement for 1.5 overload.

15.10 Gear Ratio	
Coding	RW
Range:	100 – 1999 (16.29 = 0) 10 – 1999 (16.29 = 1)
Units:	0.01 (16.29 = 0) : 0.1 (16.29 = 1)

Enter the total speed reduction ratio between the motor and the winder shaft.

The resolution/range can be changed by parameter 16.29.

16.29 = 0

Allows gear ratios between 1:1 and 1:19.99

16.29 = 1

Allows gear ratios between 1:1 and 1:199.9

15.11 Diameter Hold Threshold	
Coding	RW
Range:	1 - 255
Units:	r/min

This parameter determines the speed of the winder shaft below which the diameter calculator is frozen. This parameter is only applicable when calculating the diameter from line speed (m/min) / winder speed (r/min), (15.20.1=0).

15.12 Speed Offset	
Coding	RW
Range:	0 – 255
Units:	m/min ft/min

Sets the offset speed used when the Mentor operates in Torque modes (15.34=0). An alternative width parameter 70.35 is selected when 70.10 = 1.

15.13 Stall Tension Set Point	
Coding	RW
Range:	0 –100
Units:	Percentage

Determines the level of tension demanded under stall tension. Can be set as a percentage of the Tension Set Point or Maximum Tension. See parameter 15.20.3.

15.14 Manual Slew Rate Multiplier	
Coding	RW
Range:	1 –255
Units:	Multiplier

The manual slew rate is multiplied by the value of 15.14, this allows increased manual slew rates to be set. Maximum manual slew will be 255 * 255 microns per second.

15.16 Minimum Diameter	
Coding	RW
Range:	1 - 255
Units:	Millimetres 0.1inches

Sets the low limit of the diameter range should be set equal to the mandrel diameter. Where several mandrel sizes are used, set this parameter to the smallest diameter. This is only applicable when the diameter is determined from line speed (m/min) / winder speed (r/min), (15.20.1=0). If lap counting is used (15.20.1=1) then the start diameter must be set accurately for each mandrel size.

An alternative wide range minimum diameter parameter 70.04 is selected when 70.10 = 1.

15.17 Preset diameter value 1		
Coding	RW, U	
Range:	Min and Max diameter [15.16-1.17]	
Units:	Millimetres	0.1inches

The new diameter to which the diameter calculator will be set on operation of parameter 15.28 is entered into this parameter. This parameter is selected as the preset value source when parameter 15.22 = 1 and 15.30 = 0. If parameter 15.22= 0, the preset value is obtained via parameter 7.03 (Terminal 6) analogue input. The resulting value is displayed in parameters 15.02 / 71.02.

15.18 Material Gauge Low part		
Coding	RW	
Range:	1 – 255	
Units:	Microns	0.001inches

Used to calibrate the diameter calculator when operating in lap count mode (15.20.1=1). The gauge is also be used to dynamically calculate the diameter-slewing rate when the diameter is determined from line speed (m/min) / winder speed (r/min), (15.20.1=0).

15.19 Material Gauge High part		
Coding	RW	
Range:	1 – 255	
Units:	0.1 Millimetres	0.1inches

Used to calibrate the diameter calculator when operating in lap count mode (15.20.1=1). The gauge is also be used to dynamically calculate the diameter-slewing rate when the diameter is determined from line speed (m/min) / winder speed (r/min), (15.20.1=0).

The material gauge is calculated as:

$$\text{High part} * 100 + \text{Low part}$$

A Gauge of 1234 microns may be input as:

$$\#15.18 = 34 \#15.19 = 12$$

An alternative single wide range maximum diameter parameter 70.07 is selected when 70.10 = 1.

15.20	Software configuration parameter
Coding	RW
Range:	1 – 255
Units:	Binary weighted

In order to conserve parameter usage this parameter is used to select certain functions of the application, which once set are not normally changed. Each bit of the parameter is allocated to a particular function. Functions are assigned by adding the relevant binary weighted decimal value for the required bit to 15.20. The value displayed in 15.20 will be the total of the weighted values of the bits which have been set.

Bit weightings

Bit	Weighting
0	1
1	2
2	4
3	8
4	16
5	32
6	64
7	128
Total	255

Example

Select CTNet speed reference bit 0 = 1 weighting	1
Enable Watch Dog bit 6 = 1 weighting	64
Total value	65

The assignment of the various bits 0 – 7 are listed below.

15.20.0 Select Digital Line Speed Input	
Coding	RW, Bit

This parameter when set causes the software to obtain the line speed and acceleration references from registers 73.01 and 73.02. These parameters values are intended to be set via fieldbus serial communication and have been purposely define to these registers so the values can be easy derived with CTNet using the cyclic channels. The speed and acceleration data should be presented as follows: -

73.01 = Speed reference (0 – 16000 equivalent to 0 – Max Speed)

73.02 = Acceleration rate (16000 equivalent to 0 – Max Speed in 1 Second)

NOTE Dancer or Load cell analogue feedback connected to terminal 7, (0 – 10V signal, 10bit resolution)

When this parameter is not set then the line speed reference will be obtained either from the analogue source parameter 7.05 or from the line encoder via 90.01 and the acceleration rate will be obtained from the differential of this value.

NOTE Dancer or Load cell analogue feedback connected to terminal 3 for higher resolution feedback, (0 – 10V or 0/4-20mA signals can be used, 12bit resolution).

The Line encoder parameter must be deselected 70.27 = 0.

15.20.1 Diameter Calculation Mode	
Coding	RW, Bit Weighting 2

Selects the software to calculate diameter either by dividing Line speed(m/min) by Winder speed (r/min) or by counting rotations of the winder shaft and multiplying by gauge.

0 = Diameter by (m/min) / (r/min)

1 = Diameter by Count * 2 * Gauge

15.20.1 signifies bit 1 of parameter 15.20 to set it add 2 to the value in 15.20.

15.20.2 Select Dancer or Load cell operation	
Coding	RW

In speed mode the tension feedback to the PID control may be from a Dancer or Load cell. Depending upon the selection the set points must be selected to suit.

Dancer control requires a position set point 15.20.2 = 0

Load cell control requires a tension set point 15.20.2 = 1

15.20.2 signifies bit 2 of parameter 15.20. It may be set by adding 4 to the value in 15.20.

15.20.3 Stall Mode	
Coding	RW, Bit

Determines the tension setting to be used under stall conditions.

- 0 = Stall Tension set to a fixed percentage of Tension set point
- 1 = Stall Tension set to a fixed percentage of Maximum Tension

15.20.3 signifies bit 3 of parameter 15.20 it may be set on by adding 8 to the value in 15.20.

15.20.4 Select Fixed Diameter Slew Limit	
Coding	RW, Bit

This parameter when set causes the software to use the slew rate set in parameter 16.13, when not set the slew rate will be calculated from gauge and revolutions per second. Giving a limit value, which is automatically adjusted for line speed and diameter.

This parameter is only applicable when calculating the diameter from line speed (m/min) / winder speed (r/min), (15.20.1=0).

Activated by adding 16 to the value in 15.20.

15.20.5 Acceleration signal selection	
Coding	RW, Bit

Allows a choice between an internally generated an externally provided value of acceleration rate for use by the Inertia compensation routine. When parameter 15.20.5 = 0 the inertia compensation calculation is performed, using a signal produced by differentiating the line speed reference. The differential sample time can be adjusted by parameter 70.23.

When parameter 15.20.5 = 1, the acceleration signal is read from a register, which is derived via serial communications from an external source via 73.02.

Activated by adding 32 to the value in 15.20.

15.20.6 Watch dog enable	
Coding	RW, Bit

Enables the watchdog monitor, which checks for continuity of the serial communication with an external controller or MMI.

Activated by adding 64 to the value in 15.20.

15.20.7 Select Back EMF mode	
Coding	RW, Bit

When 15.20.7 = 1 the operation of the field current controller is changed from it's normal armature voltage limiting function to a straight forward current regulator which sets the field current in relation to diameter.

Activated by adding 128 to the value in 15.20.

The profile of field current against diameter is stored in a look up table. This table must be programmed by the user, locations 70.80 – 70.89 contain values of diameter (millimetres) and locations 71.80 – 71.89 hold the equivalent values of required field current (0 – 1000 DUs). The field current controller must first be calibrated to give the required maximum current.

15.21 Loss profiler enable	
Coding	RW, Bit

Selects a linear interpolating profiler to provide a complex loss compensation function instead of the simple fixed friction and linear viscous compensation obtained using 16.16 and 16.17.

- 0 = Simple loss comp (see 16.16 & 16.17)
- 1 = Complex loss comp (see 70.70-70.79)

15.22 Select Diameter Set Point from Digital Source	
Coding	RW, Bit

Setting this bit will cause the software to obtain the tension set point from several parameters.

- 15.30 = 0 & 70.53 = 0 Source 15.17
- 15.30 = 1 & 70.53 = 0 Source 1.19
- 15.30 = 0 & 70.53 = 1 Source 70.51
- 15.30 = 1 & 70.53 = 1 Source 70.52

Data should be passed to these preset source parameters in Millimetres or tenths from a suitable digital source, MMI or PLC using serial communications access. This value will then be used during the diameter preset routine instead of parameter 7.03.

When set to 0, the Diameter set point is derived from an analogue source to parameter 7.03.

15.23 Tension On	
Coding	RW, Bit

Enables the tension control functions within the software.

In Speed Mode the Centreing routine will operate before full tension control is enabled.

Tension On is normally enabled once the winder has been threaded with material.

15.24	Enable Acquire (Speed mode only)
Coding	RW, Bit

When set to 1 the software will multiply the diameter slew rate by the value in 70.33 for the duration of the controlling signal up to a limit of 10 seconds at which point it will be removed by an internal timer.

15.25	Direct Diameter Measurement
Coding	RW, Bit

Sets the software to read an analogue input as diameter allowing use of the winder software with a diameter transducer.

The analogue input of diameter can only be routed via terminal 6.

15.26	Over / Under Wind
Coding	RW, Bit LOCKED WHILE THE DRIVE IS ENABLED

Selects the direction of rotation of the winder.

15.27	Enable Slack Web detection (Speed mode only)
Coding	RW, Bit

When set to 1 the software will attempt to detect a slack web by monitoring the Dancer or Lad cell feed back signal level compared with 70.32

15.28	Preset Diameter
Coding	RW, Bit

Sets the calculated diameter to the preset value displayed in parameter 15.02 / 71.02, see 15.30 for details of preset source selection. The preset function is only active when Tension On (15.23) is not enabled.

15.29	Unwind Mode
Coding	RW, Bit LOCKED WHILE THE DRIVE IS ENABLED

Selects the software to control the winder as an Unwind.

15.30	Select second preset diameter
Coding	RW, Bit

Selects 1.19 or 70.52 as the value used to preset diameter when 15.28 is activated.

15.31	PID Enable
Coding	RW, Bit

Enables PID action for closed loop tension control, in Speed Mode this signal is ANDed with a flag from the Centreing Routine preventing PID action being invoked until the dancer has been positioned.

15.32	PID Hold
Coding	RW, Bit

Holds the integral term of the PID controller.

15.33	PID Integral Reset
Coding	RW, Bit

Zeros the integral term of the PID controller.

15.34	Speed Mode
Coding	RW, Bit

Selects the software to operate in either Torque or Speed Mode.

0 = Torque Mode

1 = Speed Mode

15.35	Diameter Calculation Error Flag
Coding	RW, Bit

Indicates that there is a transient error in the result produced by the (m/min) / (r/min) calculation.

15.36	Web Break Flag
Coding	RO, Bit

Indicates that a large mis-match in the speed of the line and the speed of the winder has occurred indicating a material breakage. This flag will stay set on detection until the winder is stopped, e.g. when the reference on parameter 1.11=0 then this flag will be reset.

15.37	Enable Coupling
--------------	------------------------

When set on the drive will rotate at fixed RPM independent of diameter to allow alignment of the coupling splines. RPM speed reference is set in 70.40 and reduced current limit level in 70.41.

15.38	Indication of Torque demand	
Coding	RO	
Range	0 - 1000	
Units	PU	

Indicates the level of current demand adjusted for flux compensation, making the value proportional to actual torque. Intended for use when measuring loss torque to calibrate the loss profiler.

15.39	PID Output	
Coding	RO	
Range:	0 – 255	
Units:	Speed Mode: cm/min Torque Mode: 0.1%	Speed Mode: 0.01ft/min Torque Mode: 0.1%

Indicates the output level of the PID controller.

15.40	Diameter Hold Flag	
Coding	RO,Bit	

Indicates when the diameter hold function is activated.

15.50	Maximum Motor Speed (High part)	
Coding	RO	
Range	0 - 255	
Units	RPM	

Indicates thousands and hundreds of maximum motor speed.
Use in conjunction with 15.51 to calibrate the tacho feed back.

15.51	Maximum Motor Speed (Low part)	
Coding	RO	
Range	0 - 255	
Units	RPM	

Indicates tens and units of maximum motor speed.
Use in conjunction with 15.50 to calibrate the tacho feed back.

8.3.2 Menu 16

16.01 Tension Current	
Coding	RO
Range:	0 - 1999
Units:	Amps

Indicates the value of current output deemed to be proportional to tension.

16.02 Compensation Current	
Coding	RO
Range:	0 - 1999
Units:	Amps

Indicates the value of current output deemed to be proportional to inertia and frictional compensation.

16.03 PID Error		
Coding	RO	
Range:	0 - 1999	
Units:	Speed Mode: PU dancer position Torque Mode: 0.1% Newtons	Speed Mode: PU dancer position Torque Mode: 0.1% Newtons

Indicates the error seen by the PID controller.

16.04 Final Speed Reference		
Coding	RO	
Range:	0 – 1999	
Units:	m/min	ft/min

This parameter indicates:

Speed Mode - The demanded speed Reference.

Torque Mode - The Speed Override value.

An alternative full range final speed reference display is available in 71.04.

16.05 Acceleration rate		
Coding	RO	
Range:	0 – 1999	
Units:	m/min/s	ft/min/sec

Displays the actual acceleration rate used for inertia compensation in metres per minute per second.

16.06 Material Width		
Coding	RW	
Range:	1 - 1999	
Units:	Millimetres	0.1inches

Set to the width of material being wound, if width variations are small then set to the maximum. If large changes in width are to be accommodated then set for each product. This value is used in calculating the inertia of the wound roll.

An alternative width parameter 70.02 is selected when 70.10 = 1.

16.07 Material Density		
Coding	RW	
Range:	1 - 1999	
Units:	kg/m ³ /10	lb/ft ³ /10

This parameter is multiplied by 10 internally to provide a practical range

Set to the density of the material to be wound, Used in calculating the inertia of the wound roll. An alternative kg/m³ / lb/ft³ density parameter 70.03 is selected when 70.10 = 1.

Typical Metric values are:

Data in Para	70.03	16.07
Paper	1200	120
Aluminum	2800	280
Mild Steel	7860	786
Stainless Steel	7930	793
Brass	8500	850

Values for other materials should be checked with the machine supplier or user.

In some applications the actual density of the roll may be somewhat less than the density of the material due to the entrapment of air during the winding process. This can result in reductions in effective roll density of up to 25%.

To measure the density of a roll, take the weight in kg and divide by the volume in cubic metres.

The volume may be quickly estimated by measuring the width and multiplying by the cross sectional area.

$$\text{Volume} = \frac{\text{Pi} * (\text{OD}^2 - \text{ID}^2)}{4} * \text{Width}$$

All measurements are in metres.

$$\text{Density} = \frac{\text{Weight}}{\text{Volume}}$$

Remember to subtract the weight of the mandrel when assessing total material weight.

16.08 Mandrel Inertia		
Coding	RW	
Range:	0 - 1999	
Units:	kg.m ²	lb.ft ²

Used in calculating the total winder inertia.

The inertia of the winder mandrel and any other rotating parts, this value should be as referred to the winder shaft. Units are in kg.m².

This value may be estimated using.

$$\text{Inertia} = \frac{\text{PixDensity} \times \text{Width} \times (\text{OD}^4 - \text{ID}^4)}{32}$$

All dimensions are in metres.

Density in kgm³.

Density relates to the material of the mandrel; mild steel, for example.

16.09 Maximum Line Speed		
Coding	RW	
Range:	1 - 1999	
Units:	m/min	ft/min

Used to scale the winder software.

An alternative maximum line speed parameter 70.01 is selected when 70.10 = 1. This allows line speeds greater than 1999 to be handled.

16.10 Maximum Tension base		
Coding	RW	
Range:	1 – 1999	
Units:	Newtons	lbf

Used to scale the winder software.

Maximum tension is calculated as 16.10 * 16.11. An alternative maximum tension parameter 70.00 is selected when 70.10 = 1.

16.11 Maximum Tension multiplier		
Coding	RW	
Range:	1 – 1999	
Units:	Newtons	lbf

Used to scale the winder software.

Maximum tension is calculated as 16.10 * 16.11. An alternative maximum tension parameter 70.00 is selected when 70.10 = 1.

16.12 Centring Window	
Coding	RW
Range:	0 - 255 = 0 - 100% of max line speed
Units:	None

Sets the width of the window around the target position for the dancer centring routine. When operating with a dancer in speed mode enabling Tension On will result in the centring routine positioning the dancer at this position before the PID control is enabled. The width of the centring window is automatically scaled such that 255 always equates to maximum line speed, hence setting to 255 causes the centring routine to be effectively overridden, a requirement for some turret winder applications.

16.13 Diameter Slew Rate (Fixed)		
Coding	RW	
Range:	1 - 255	
Units:	Microns per second	0.001inches/sec

The result produced by the diameter calculator (m/min) / (r/min) when selected (15.20.1=0), can be noisy resulting in transient fluctuations of torque an effective method of reducing this noise is to limit the rate of change of this signal. Slewing rate limit can either be calculated dynamically by the software using the material gauge or set at a pre-determined value as selected by parameter 15.20.4.

This parameter sets the slew rate for the fixed option.

16.14 Threading Speed		
Coding	RW	
Range:	0 – 255	
Units:	m/min	ft/min

This parameter sets the speed at which the winder will run during inching. Values are entered in m/min and the system will produce a value of r/min corrected for diameter. It is essential therefore that the diameter is initialised to the correct value before the inch function is used. Setting Inch forward parameter 8.03, or Inch reverse parameter 8.02 enables inching when tension is off. Inch speed will be limited to maximum line speed if the value of 16.14 exceeds this value.

16.15 Friction Compensation (Static)	
Coding	RW
Range:	0 - 255
Units:	0.1%

This parameter sets the percentage of maximum motor torque to overcome static friction. Range 0 – 25.5% with a resolution of 0.1%.

Only applicable when the compensation is selected, (04.11 = 1) and 15.21 = 0 (Profiler not selected).

16.16 Friction Compensation (Viscous)	
Coding	RW
Range:	0 - 255
Units:	0.1%

This parameter sets the percentage of maximum motor torque produced at maximum speed to overcome viscous friction. Range 0-25.5 with a of 0.1%.

Only applicable when the compensation is selected, (04.11 = 1) and 15.21 = 0 (Profiler not selected).

16.17 Taper Start Diameter	
Coding	RW
Range:	Min diameter - 255
Units:	Millimetres 0.1inches

Determines the diameter reached before taper tension is applied, set to minimum diameter as default.

16.18 Tension Slew Time	
Coding	RW
Range:	1 - 255
Units:	0.1Seconds

This parameter sets the ramp time applied to the tension set point. Ramping the tension reference prevents shock transients being applied to the material when operator tension changes are made.

16.19 Motor Inertia	
Coding	RW
Range:	0 - 255
Units:	Kg.m ² lb.ft ²

Used in calculating the total inertia.

16.20 Dancer Position Set Point	
Coding	RW
Range:	0 - 255
Units:	Per Unit

This parameter sets the target position for the dancer when operating in Speed Mode. The value in 16.20 is multiplied by 4 and compared with the dancer feedback signal range 0 – 1000, setting to 122 will target the centre point is full range is available from the dancer.

Check the actual dancer feedback range in 7.04 before setting.

16.21	Select Torque Memory mode
--------------	----------------------------------

When activated causes the winder to change from speed control to a memorised average level of torque measured during the period just prior to activation. In torque mode holds the current value of tension torque. Allows the winder to continue operation without the intervention of the load cell or dancer during turret changeovers. Should be de-activated immediately the roll transfer has been completed.

16.22	Enable Lay On Roll tension boost
--------------	---

Coding	RW, Bit
--------	---------

When activated the tension set point is increased by the value in 70.25.

16.23	Enable Index Tension boost
--------------	-----------------------------------

Coding	RW, Bit
--------	---------

When activated the tension set point is increased by the value in 70.24.

16.24	Enable Speed Boost
--------------	---------------------------

Coding	RW, Bit
--------	---------

When activated the value in 70.26 is added to the line speed reference, can be used to modify the winder speed during turret changeovers.

16.25	Lap count reversal
--------------	---------------------------

Coding	RW, Bit
--------	---------

Reverses the direction of the diameter change when lap or traverse mode are selected. Provides compensation for differences between winder shaft and motor directions of rotation. Winder diameters should increment and Unwind diameters should decrement.

16.26	End of traverse limit switch input (Traverse mode)
--------------	---

Coding	RW, Bit
--------	---------

Signals a change in direction of the traverse mechanism calling for the diameter to be increased by another layer.

16.27	Select traverse mode
--------------	-----------------------------

Coding	RW, Bit
--------	---------

Modifies the lap counting function to operate in traverse mode incrementing diameter whenever a positive edge is detected on parameter 16.27.

16.28	Hyperbolic Taper select
--------------	--------------------------------

Coding	RW, Bit
--------	---------

This determines the type of profile to be used when taper tension is required:

- 0 – Linear taper
- 1 – Hyperbolic taper

16.34 Select Quantum

Configures the internal logic to suit Quantum digital I/O.

Jog Fwd = F2+F3+F4

Jog Rev = F2 + F3

Line Run = F2

16.35 Web tensioned flag

Coding	RO, Bit
--------	---------

Set when the dancer is within the target area after selection of tension on in speed mode. Indicates that the PID has control and the line can be started. This flag is set when load cell is used, and tension is on in speed mode.

16.36 Watch Dog trip

Coding	RO, Bit
--------	---------

Indicates a loss of serial communications with an external controller if the watchdog has been enabled and no response is received within the watchdog scan time.

16.38 Motor Speed (High part)

Coding	RO
Range	0 - 255
Units	RPM

Indicates thousands and hundreds of motor RPM.

16.39 Motor Speed (Low part)

Coding	RO
Range	0 - 255
Units	RPM

Indicates tens and units of motor RPM.

8.3.3 Menu 70

70.00 Maximum Line Tension (Alternative register)		
Coding	RW	
Range:	0 – 2 ³²	
Units:	Newtons	lbf

Allows direct input of the Maximum Line Tension scaler from a terminal or similar device in Engineering Units. Replaces 16.10 * 16.11 when 70.10 = 1.

Selected when 70.10 = 1.

70.01 Maximum Line Speed (Alternative register)		
Coding	RW	
Range:	0 – 2 ³²	
Units:	m/min	ft/min

Allows direct input of the Maximum Line Speed scaler from a terminal or similar device in Engineering Units. Replaces 16.09 when 70.10 = 1.

Selected when 70.10 = 1.

70.02 Material Width (Alternative register)		
Coding	RW	
Range:	1 - 2 ³²	
Units:	Millimetres	0.1inches

Set to the width of material being wound, if width variations are small then set to the maximum. If large changes in width are to be accommodated then set for each product. This value is used in calculating the inertia of the wound roll. Replaces 16.06 when 70.10 = 1.

Selected when 70.10 = 1.

70.03 Density (Alternative register)		
Coding	RW	
Range:	0 – 2 ³²	
Units:	kg/m ³	lb/ft ³

Allows direct input of the Material Density scaler from a terminal or similar device in Engineering Units. Selected when 70.10 = 1.

Set to the density of the material to be wound, Used in calculating the inertia of the wound roll. Replaces 16.07 when 70.10 = 1.

Typical Metric values are:

Data in Para	70.03
Paper	1200
Aluminum	2800
Mild Steel	7860
Stainless Steel	7930
Brass	8500

Values for other materials should be checked with the machine supplier or user.

In some applications the actual density of the roll may be somewhat less than the density of the material due to the entrapment of air during the winding process. This can result in reductions in effective roll density of up to 25%.

To measure the density of a roll, take the weight in kg and divide by the volume in cubic metres.

The volume may be quickly estimated by measuring the width and multiplying by the cross sectional area.

$$\text{Volume} = \frac{\text{Pi} * (\text{OD}^2 - \text{ID}^2)}{4} * \text{Width}$$

All measurements are in metres.

$$\text{Density} = \frac{\text{Weight}}{\text{Volume}}$$

Remember to subtract the weight of the mandrel when assessing total material weight.

70.04 Minimum Diameter (Alternative register)		
Coding	RW	
Range:	1 - 2 ³²	
Units:	Millimetres	0.1inches

Sets the low limit of the diameter range should be set equal to the mandrel diameter. Where several mandrel sizes are used, set this parameter to the smallest diameter. This is only applicable when the diameter is determined from line speed (m/min) / winder speed (r/min), (15.20.1=0). If lap counting is used (15.20.1=1) then the start diameter must be set accurately for each mandrel size. Replaces 15.16 when 70.10 = 1.

Selected when 70.10 = 1.

70.11	Select Tension Set Point from Digital Source
Coding	RW, Bit

Setting this bit will cause the software to obtain the tension set point from parameter 70.08. Data should be passed to parameter 70.08 in Newtons from a suitable digital source, MMI or PLC using serial communications access.

When set to 0, the tension set point is derived from an analogue input terminal 4.

70.12	Select Taper Set Point from Digital Source
Coding	RW, Bit

Setting this bit will cause the software to obtain the tension set point from parameter 70.09. Data should be passed to parameter 70.09 in per unit format from a suitable digital source, MMI or PLC using serial communications access. The percentage taper set will occur at maximum diameter.

When set to 0, the Taper set point is derived from an analogue input terminal 5.

70.13	Select Alternative PID gain registers
Coding	RW, Bit

Setting this bit will cause select an alternative set of PID gains from 70.14 –70.16, allowing a wider set up range than is available from the Key Pad parameters. See list below.

70.14	PID P Gain (Alternative register)
Coding	RW
Range:	0 – 2 ³²
Units:	0.001Kp

Sets the gain of the P term when using the PID to provide closed loop tension control. A value of 1000 gives unity gain.

Selected when 70.13 = 1

70.15	PID Integral Gain (Alternative register)
Coding	RW
Range:	0 – 2 ³²
Units:	0.1Ki.sec

Sets the gain of the I term when using the PID to provide closed loop tension control.

Selected when 70.13 = 1

70.23 Differentiator scan time	
Coding	RW
Range:	0 - 100
Units:	Multiples of 10 milliseconds

Sets the scan time for the differentiator, which provides a measure of acceleration rate for use by the inertia compensation function. The differentiator is not used if an external rate signal is selected by parameter 15.20.5.

70.24 Index tension boost value	
Coding	RW
Range:	+/-1000
Units:	Percentage of running tension 0.1%

Sets the increase in tension set point to compensate for errors during turret indexing.

70.25 Lay On tension boost value	
Coding	RW
Range:	+/-1000
Units:	Percentage of maximum tension 0.1%

Sets the increase in tension set point to compensate for the losses during contact with the lay on roll during roll changes.

70.26 Speed boost value	
Coding	RW
Range:	+/-10% of Maximum line speed
Units:	% of MPM : % of ft/min

Sets the increase in line speed set point can be used to increase the incoming roll speed during splicing. This is limited to 10% of maximum line speed.

70.27 Select line speed reference from encoder	
Coding	RW, Bit

When set the winder will derive the line speed reference from an encoder signal. The second encoder should be connected to PL4 of the MDA2.

70.29 Time base for line encoder speed measurement	
Coding	RW
Range:	10 - 10000
Units:	milliseconds

In order to provide the diameter calculation block with a smooth and accurate measurement of line speed when using an incremental encoder reference. The encoder count is accumulated over an extended time base. The default is set to 100

milliseconds, increasing this time will slow the rate at which the line speed reference is updated but reduce any signal flicker, reducing the time will increase the update rate but may result in increased signal noise levels.

70.30 Line encoder RPM at maximum line speed	
Coding	RW
Range:	0-2 ³²
Units:	r/min

This value calibrates the internal frequency measurement to match the required line speed reference signal. The speed should be that attained by the line encoder when the machine is running at the maximum line speed as input in 16.09 or 70.01.

70.32 Slack Web detection threshold	
Coding	RW
Range:	0 - 1000
Units:	0.1 percent

If the Dancer or Load Cell feed back level falls below this value the software will assume that the web is out of control.

70.33 Diameter acquire multiplier factor	
Coding	RW
Range:	1 - 1000
Units:	Per Unit

The factor by which the diameter slew rate will be multiplied when the acquire function is activated.

70.34 Enable Acquire on start up (Speed mode only)	
Coding	RW, Bit

When set to 1 the software will multiply the diameter slewing rate by the value in 70.33. for 10 seconds after every start up from a tension off condition.

70.35 Coiler Offset Speed (Alternative register)		
Coding	RW	
Range:	0 – 2 ³²	
Units:	m/min	ft/min

Sets the offset speed used when the Mentor operates in Torque modes (15.34=0).

Replaces 15.12 when 70.10 = 1.

Selected when 70.10 = 1.

70.36 Slewing lower threshold to activate hold diameter	
Coding	RW
Range:	0 - 2 ³²
Units:	μm/s (0.001ins/s)

The result produced by the diameter calculator in ratio mode will be inconsistent at low speeds. To avoid problems the diameter result is held at low speeds and low slew rates. 70.36 sets the lower limit on slew rate below which the diameter hold function will be activated. Default value is 200.

70.37 Start speed for PID gain profiler	
Coding	RW
Range:	0 - 100
Units:	Percent of maximum speed

When operating in Speed Mode the gain of the PID is profiled against line speed. 70.37 allows the lower limit of this profiler to be adjusted, hence limiting the reduction in gain at lower speeds ensuring adequate control margin from the PID is available. Default is set at 10% gain range of 10:1 over the line speed range.

70.38 Preset length count	
Coding	RW, Bit

Resets the material length count in 70.19 to zero.

70.40 Coupling Speed Reference		
Coding	RW, U	
Range:	0 – 10	
Units:	r/min	r/min

Speed reference used to run the drive when coupling is enabled (15.37 = 1). Allows the winder to rotate at a fixed rotational speed independent of diameter whilst the splines are aligned.

70.41 Coupling Current Limit Value		
Coding	RW, U	
Range:	0 – 1000	
Units:	%	%

Sets a reduced current limit whilst the coupling function is enabled.

70.42 At Line Speed acceptance window Value		
Coding	RW, U	
Range:	0 – Max MPM / FPM	
Units:	0.1 mpm	0.1 fpm

Sets the acceptance band of the check on peripheral speed equal to line speed for splicing applications. When speed match condition is satisfied bit 11 of the Status Word will be set.

70.43 CTNET Output Data Select		
Coding	RW, B	
Range:	-1 to 255	

Set -1 to broadcast data to all CTNet nodes on the network.

Set >0 to specific node address for the CTNet to transmitted to.

Set to 0 disables this function.

Winder Parameter	Description	Target Node Receiving registers
72.70	Statusword 1	73.70
72.71	Statusword 2	73.71
71.06	Actual Tension/Dancer Feedback	73.72
71.01	Actual Diameter	73.73
71.07	Tension Feed-forward	73.74

70.49 Application Software Version		
Coding	R0, U	

This indicates the current duty assist application software version used within the application module.

The parameter version is displayed as an integer value for example, 10208 denotes V01.02.08.

70.51	Alternate Preset diameter value 1	
Coding	RW, U	
Range:	Min and Max diameter	
Units:	Millimetres	0.1inches

The new diameter to which the diameter calculator will be set on operation of parameter 15.28 is entered into this parameter. This parameter is selected as the preset value source when parameter 15.22 = 1 and 15.30 = 0. If parameter 15.22= 0, the preset value is obtained via parameter 7.03 (Terminal 6) analogue input. The resulting value is displayed in parameters 15.02 / 71.02.

This is selected when 70.53 = 1

70.52	Alternate Preset diameter value 2	
Coding	RW,	
Range:	Min and Max diameter	
Units:	Millimetres	0.1inches

The new diameter to which the diameter calculator will be set on operation of parameter 15.28 is entered into this parameter. This parameter is selected as the preset value source when parameter 15.22 = 1 and 15.30 = 1. If parameter 15.22= 0, the preset value is obtained via parameter 7.03 (Terminal 6) analogue input. The resulting value is displayed in parameters 15.02 / 71.02.

This is selected when 70.53 = 1

70.53	Select Alternate Preset Diameters	
Coding	RW, Bit	

When set selects 70.51 and 70.52 as the preset parameters.

70.54	Torque demand	
Coding	R0, Uni	
Range:	0 - 1000	
Units:	0.1%	

This indicates the actual percent torque demanded corrected for flux compensation. Used for setting up of the loss profiler.

70.55	Loss Profiler Pointer	
Coding	RO, U	
Range:	0 – 10	

This indicates the position within the loss table, which is currently being used.

70.61 CTNet In Mapping Parameter 2 (from _S03% (73.03))	
Coding	RW, U
Range:	100 - 9999
Units:	-

This parameter details the destination parameter for the data within parameter _S03% (73.03). This is intended for CTNet networks, where additional cyclic data maybe required to be mapped into the winder software.

The required destination parameter number is entered in the following format 1911, (=19.11). 0 or a multiple of 100 will disable the mapping.

NOTE This parameter mapping is updated every 10 milliseconds for where real-time data is required to be source from another CTNet node. Care must be taken when mapping to low priority parameters, as it is important to ensure the source data remains within the range of the destination parameter.

70.62 CTNet In Mapping Parameter 3 (from _S00% (73.04))	
Coding	RW, U
Range:	100 - 9999
Units:	-

This parameter details the destination parameter for the data within parameter _S04% (73.04). This is intended for CTNet networks, where additional cyclic data maybe required to be mapped into the winder software.

The required destination parameter number is entered in the following format 1911, (=19.11). 0 or a multiple of 100 will disable the mapping.

NOTE This parameter mapping is updated every 10 milliseconds for where real-time data is required to be source from another CTNet node. Care must be taken when mapping to low priority parameters, as it is important to ensure the source data remains within the range of the destination parameter.

70.63 CTNet In Mapping Parameter 4 (from _S05% (73.05))		
Coding	RW, U	
Range:	100 - 9999	
Units:	-	

This parameter details the destination parameter for the data within parameter _S05% (73.05). This is intended for CTNet networks, where additional cyclic data maybe required to be mapped into the winder software.

The required destination parameter number is entered in the following format 1911, (=19.11). 0 or a multiple of 100 will disable the mapping.

NOTE This parameter mapping is updated every 10 milliseconds for where real-time data is required to be source from another CTNet node. Care must be taken when mapping to low priority parameters, as it is important to ensure the source data remains within the range of the destination parameter.

70.67 CTNet output destination start register		
Coding	RW, U	
Range:	0 - 75	
Default:	70	

This set the CTNet destination start register of the receiving drive for the winder CTNet output data.

70.70 Loss profiling table, Motor speed values		
70.79		
Coding	RW	
Range:	0 – Max Motor RPM [71.08]	
Units:	RPM	N/A

These locations allow the user to enter the speed values associated with the loss compensation torque values stored in 71.70 – 71.79. Values should always be entered as motor r/min.

70.80	Field profiling table, Diameter values	
70.89		
Coding	RW	
Range:	Min and Max diameter	
Units:	Millimetres	N/A

These locations allow the user to enter the diameter values associated with the field current reference values stored in 71.80 – 71.89. Values should always be entered in millimetres. During operation Parameter 70.56 indicates the active point in the profiler while 70.99 provides an indication of actual diameter in millimetres, this information may be used if it is necessary to trim the profile while the winder is operating.

70.99	Non Volatile store for Actual Diameter	
Coding	RW	
Range:	0 – 2 ³²	
Units:	Millimetres	N/A

Used as the diameter preset value on power up. This feature is not supported on the Mentor.

8.3.4 Menu 71

Due to the limited range of data displayed in the Mentor parameters several important values are displayed at full resolution in Menu 71. This allows the user to inspect the full value without the limitation of a 1999 maximum limit and also provides a location for access to this data for display on an MMI.

71.01	Actual diameter	
Coding	RO	
Range:	Minimum diameter – Maximum diameter	
Units:	Millimetres	Tenths

Indicates the current diameter.

Equivalent to the actual radius value displayed in 15.01

71.02	Preset diameter	
Coding	RO	
Range:	Minimum diameter – Maximum diameter	
Units:	Millimetres	Tenths

Indicates the current preset diameter.

Equivalent to the preset radius value displayed in 15.02.

71.03 Line Speed Reference		
Coding	RO	
Range:	0 –Maximum line speed	
Units:	M/min	Ft/min

Indicates the line speed reference.

Equivalent to the value displayed in 15.04.

71.04 Final Target Speed		
Coding	RO	
Range:	0 –Maximum line speed	
Units:	M/min	Ft/min

Indicates the final linear speed reference after that effects of Speed Offsets, Speed boost and PID trim.

Equivalent to the preset radius value displayed in 16.04

71.05 Motor Speed		
Coding	RO	
Range:	0 – Maximum motor speed	
Units:	RPM	

Indicates the current motor speed.

This value may be used to implement line speed limitation in the master drive to prevent winder over speed at reduced diameters.

71.06 Tension Feedback in EGUs		
Coding	RO	
Range:	0 – Max winder tension (16.10*16.11) or 70.00 if 70.10 = 1	
Units:	Newtons	lbf

Displays the actual Tension as measured by a load cell in Engineering Units.

71.07 Actual Tension Set Point post ramp		
Coding	RO	
Range:	0 – Max winder tension (16.10*16.11) or 70.00 if 70.10 = 1	
Units:	Newtons	lbf

Indicates the value of the final tension reference after taper has been applied. The data is taken from the output of the tension reference ramp and relates directly to the tension to be produced by the winder. This signal is intended for use when tension feed forward torque compensation is required in the speed controlled master drive a technique used on high performance high-speed winders. The value is provided in Newtons.

71.08	Maximum motor speed	
Coding	RO, U	
Range:	0 – 2 ³²	
Units:	r/min	

Displays the maximum required motor speed to allow calibration of the tacho feedback when no encoder is used.

71.09	Final Tension reference	
Coding	RO, U	
Range:	0 – 2 ³²	
Units:	Newtons	lbf

Provides a means of checking the tension reference value after the selection between Stall and Run values. Reads negative if Unwind bit is set.

71.10	Final Tension reference - pre-ramp	
Coding	RO, U	
Range:	0 – 2 ³²	
Units:	Newtons	lbf

Monitors the tension reference value at the input to the tension ramp generator. Provides a means of checking the tension reference value after the effect of taper tension.

71.11	Actual Slew rate limit applied to diameter calculation	
Coding	RO, U	
Range:	0 – 2 ³²	
Units:	microns/second	microns/second

Monitors the slew limit value applied to the result of the ratio diameter calculation. Will be seen to increase with winder rotational speed.

71.12	Calculated diameter before slew limiting	
Coding	RO, U	
Range:	0 – 2 ³²	
Units:	mm	tenths

Allows a check on the result of the calculation Line speed / Winder r/min before the slew limiter.

71.70 - 71.79	Loss profiling table, Percentage compensation torque	
Coding	RW	
Range:	0 – 1000	
Units:	0.1 percent	N/A

These locations allow the user to enter the required compensation values associated with the speeds stored in 70.70 – 70.79. An indication of actual torque demand may be obtained from 70.54.

71.80 - 71.89	Field profiling table, Field current reference values	
Coding	RW	
Range:	0 – 1000	
Units:	0.1 Percent	N/A

These locations allow the user to enter the required field current reference values associated with the diameters stored in 70.80 – 70.89. Initial values should be estimated from knowledge of the motor field / speed characteristic at constant armature voltage. Final trimming may be made from observation of any deviations in armature voltage at constant line speed as the roll diameter builds. Parameter 70.56 indicates the active location within the profiling table whilst 70.99 indicates the actual diameter in millimetres.

8.3.5 Menu 72

CTNet access is located in Menu 72

72.70	Status Word 1
Coding	RW, Bipolar
Range:	0 – 65535

Serial Communication, remote status word 1. Refer to section 9.1 Control Word for more details

72.71	Status Word 2
Coding	RW, Bipolar
Range:	0 – 65535

Serial communication, remote status word 1. Refer to section 9.1 Control Word for more details

72.71	Reserved
Coding	RW, Bipolar
Range:	0 – 65535

72.71	Reserved
Coding	RW, Bipolar
Range:	0 – 65535

72.71	Reserved
Coding	RW, Bipolar
Range:	0 – 65535

8.3.6 Menu 73

CTNet access is located in Menu 73

73.01 Line Speed Reference	
Coding	RW, Bipolar
Range:	0 – 16000
Units:	Line Speed PU

The line speed reference in standardised format to maintain optimum resolution.

0 –16000 represents 0 – Maximum Line Speed (m/min)

Internal scaling is performed to convert this to m/min based upon the value of parameter 16.09 (70.01) Maximum Line Speed.

73.02 Acceleration Reference	
Coding	RW, Bipolar
Range:	0 – 16000
Units:	Line acceleration PU

The line speed reference in standardised format to maintain optimum resolution.

16000 represents Maximum Line Speed (m/min) attained in 1 second

An acceleration time of 10 seconds would result in an acceleration signal of 1600.

Internal scaling is performed to convert this to m/min per second based upon the value of parameter 16.09 Maximum Line Speed.

73.70 Control Word 1	
Coding	RW, Bipolar
Range:	0 – 65535

Serial Communication, remote control word 1. Refer to section 9.1.1 Control Word for more details

73.71 Control Word 2	
Coding	RW, Bipolar
Range:	0 – 65535

Serial communication, remote control word 1. Refer to section 9.1.1 Control Word for more details.

9 Advanced Features

9.1 Serial Communications

9.1.1 Control Word

Introduction

The fieldbus control word is an efficient way of remotely controlling the motion of a Drive. Due to the restriction of most fieldbus word length the control word length will be no more than 16bits, UD70/MD29 PLC register `_S70%` & `_S71%`, will be used to ensure full resolution is maintained (e.g. drive parameter limited to 32000 or 1000).

Standard `_S70%` (parameter 73.70)

Each bit in the fieldbus control word has a particular function, and provides a method of controlling the output functions of the Drive (RUN, JOG, TRIP, etc.) with a single data word, (16Bits).

b15	b14	b13	b12	b11	b10	b9	b8
WDin	HOLD PID	ENABL PID	PRSET DIAM	RESET PID	#13.12 IPCON	TENS ON	SAVE

b7	b6	b5	b4	b3	b2	b1	b0
TRIP	RESET		MASK	JOG REV	JOG FWD	RUN FWD	

To use the fieldbus control word motion control bits (shaded), the ENABLE terminal on the drive must be closed and the MASK bit (b4) must be set.

Motion bits are defined as:

- Jog Forward Bit 2
- Jog Reverse Bit 3
- Run Forward Bit 1
- Tension On Bit 9

Other functions may be operated at any time in parallel with their bit parameter equivalents.

When the MASK bit (b4) is reset to 0, motion control will be returned to the relevant bit parameters.

Overview of Control Word assignments

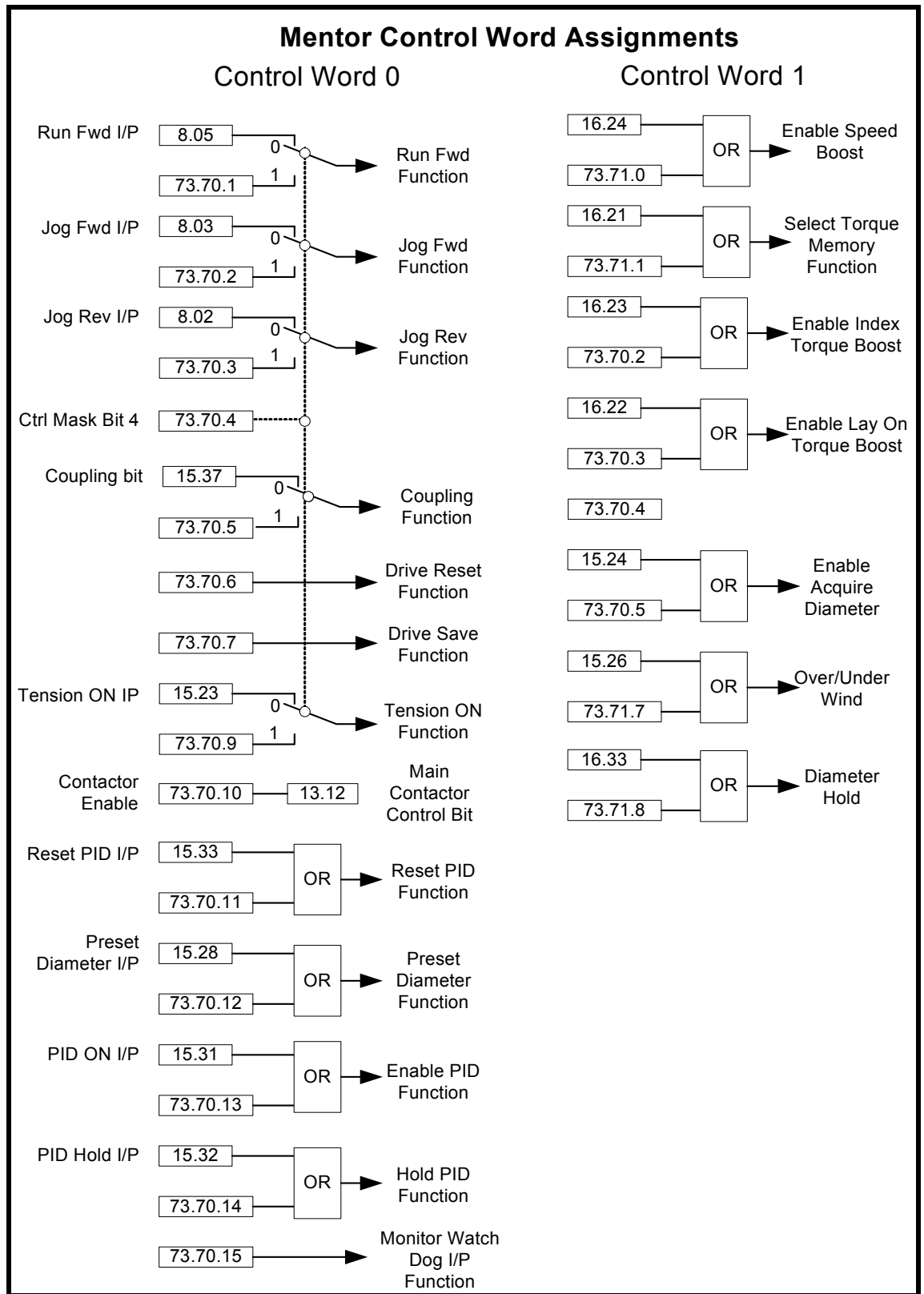

Application _S71% (parameter 73.71)

Some additional functions are provide through a second control word.

b15	b14	b13	b12	b11	b10	b9	b8
							Dia Hold

b7	b6	b5	b4	b3	b2	b1	b0
OVER UND	Acquire diam			Torque mem	Lay On boost	Index boost	Speed boost

These bits are used in exactly the same manner as those described above, the second control word mask bit must be set to 1 when a bit is to be set.

Control Word _S70% (Parameter 73.70)

Bit	Function	Description
0		The drive Enable / Disable function is not configured in the Mentor Version of this software. Use the Hardware enable terminal 31.
1	RUN FWD	Set to 1 (with ENABLE set to 1) to run the motor in the forward Line direction. When reset to 0, the winder will decelerate the motor to a controlled stop before the outputs disabled. This can also be used to control the tension set point, (stall and run tension refer to parameter 16.32.
2	JOG FWD	Set to 1 (with ENABLE set to 1) to jog/inch the winder motor in the forward line direction. When reset to 0, the Winder will decelerate the motor to a controlled stop before the outputs disabled
3	JOG REV	Set to 1 (with ENABLE set to 1) to jog/inch the winder motor in the reverse line direction. When reset to 0, the Winder will decelerate the motor to a controlled stop before the outputs disabled
4	MASK	0 = The winder is digital control is derived from the allocated bit parameters, (terminal configurable) 1 = The winder is digital control is derived from the control word. (Motion bits only)
5	COUPLING	Set to 1 (with ENABLE set to 1) to set the coupling speed function for the winder motor in the forward/reverse rotational direction. When reset to 0, the Winder will decelerate the motor to a controlled stop before the outputs disabled
6	RESET	A 0-1 transition will reset the winder from any trip condition. If the cause of the trip has not been cleared, the Drive will trip again immediately.
7	TRIP	A 0-1 transition will force a "tr99" trip on the Winder. If the RESET and TRIP bits change from 0 to 1 on the same cycle, the TRIP bit will take priority.
8	SAVE	Setting to 1 will cause the current parameter settings to be saved next time the drive is disabled. The bit will then be reset automatically.
9	TENSION ON	Set to 1 to put the drive into tension control. In torque mode this will produce stall tension, in speed mode this will enable the dancer centring routine. Once the dancer has reached target the PID tension controller will be enabled. When reset to 0, the motor will revert to speed control following the speed reference.
10	MAIN CONT.	This bit writes directly to bit parameter #13.12 and is intend to be as the remote digital signal to control the Drive power contactor. This bit can be source to a digital output on the drive. NOTE This not to be used with digital lock. This function should be disabled when using the winder solution software
11	RESET I TERM	Set to 1 to zero the value of the PID integral term
12	PRESET DIAM	Set to 1 to preset the diameter (with TENSION ON set to 0)
13	ENABLE PID	Set to 1 to enable the action of the PID controller

14	HOLD I TERM	Set to 1 to hold the value of the PID integral term
15	WDin	Watchdog In Comms clock from remote device. Reset PID

Control Word _S71% (Parameter 73.71)

Bit	Function	Description
0	SPEED BOOST	Setting to enables the Speed Boost to increase or reduce the line speed reference
1	INDEX BOOST	Setting to 1 enables the Index Torque boost
2	LAY ON BOOST	Setting to 1 enables the Lay On Torque boost
3	ENABLE TORQUE MEM	Setting to 1 puts the winder into Torque Memory mode. Only applicable when operating as a speed winder
4		The mask bit is not configured on this control word
5	Spare	
6	ENABLE ACQUIRE	Setting to 1 enables the diameter acquire function.
7	OVER/UND	Setting this to 1 will select under wind.
8	Dia. Hold	Setting this to 1, will hold the diameter calculator value

When a Drive trip occurs, the Drive automatically sets the Drive control word to 0. This ensures that, for safety reasons, the Drive does not start up immediately when it is reset. The recommended control method for the PLC program is to reset the fieldbus control word to a safe state, e.g. drive disabled, when a fault is detected in either the Application software, (The Drive control word is reset to 0 automatically when the Drive trips.) When the Serial Communication link is healthy again, the appropriate fieldbus control word can be set, a change of fieldbus control is detected, the Drive control word will be updated and the Drive will restart. Some example fieldbus control word values to control the Drive are given in the table below.

Wdin is the communication watchdog bit transmitted from remote intelligent device, (keypad or CTIU, etc).

Control Word (Hex)	Control Word (Dec)	Action
0x0000	0	Control word disabled, Drive will operate under terminal control
0x0010	16	Drive disabled
0x0011	17	Drive enabled and stopped
0x0013	19	Drive enabled and run forwards
0x0015	21	Drive enabled and Jog forwards
0x0080	128	Trip Drive
0x0040	64	Reset Drive

9.1.2 Status Word

The status word returns the status of multiple functions with the Winder system, e.g. at speed, zero speed, Drive healthy, etc., and provides a quick method of checking the current status remotely with serial communication.

Status Word1 _R70% (Parameter 72.70)

b15	b14	b13	b12	b11	b10	b9	b8
WDout	16.36			At line speed	Slack Web	Dia Hold	Max Dia

b7	b6	b5	b4	b3	b2	b1	b0
Min Dia	15.34	16.35	15.36	15.35	10.09	1.11	10.12

Bit	Parameter	Description
0	10.12	Drive healthy
1	01.11	Drive running
2	10.09	Zero speed
3	15.35	Tracking error
4	15.36	Web break
5	16.35	Tensioned
6	15.34	Speed mode selected
7		At minimum diameter
8		At maximum diameter
9		Diameter hold applied
10		Slack web detected
11		At line speed
12		
13		
14	16.36	Watchdog Error Flag
15	WDout	Watchdog out Comms. Clock

WDout is the communication watchdog bit transmitted from the UD70/MD29 to a remote intelligent device, (keypad or CTIU, etc).

Status Word2_R71% (Parameter 72.71)

Winder Status Confirmation Bits

The Winder drive can be controlled locally via the drive terminals or remotely via serial communications using the control word. This status word bits provides common acknowledgment of the commanded status of the winder drive.

b15	b14	b13	b12	b11	b10	b9	b8
			PID HOLD	PID ON	PID RST	STALL TENS	TENS ON

b7	b6	b5	b4	b3	b2	b1	b0
		COUPL	MASK	JOG REV	JOG FWD	RUN FWD	Inhibit

Bit	Parameter	Description
0	Inhibit	Drive is Inhibited
1	RUN FWD	Drive Run Forward Commanded
2	JOG FWD	Drive Jog Forward Commanded
3	JOG REV	Drive Jog Reverse Commanded
4	MASK	Mask Bit set for remote control
5	COUPL	Drive Coupling Commanded
6		
7		
8	TENS ON	Tension On Commanded
9	STALL TENS	Winder in Stall Tension
10	PID RST	PID reset commanded
11	PID ON	PID on commanded
12	PID HOLD	PID hold commanded
13		
14		
15		

9.1.3 CTNet Configurable Input Cyclic Data

To enable some of the winder parameters to be easily written to when using CTNet, four addition user configurable mapping parameter have been provided. This enables an efficient way of sending a block parameter data using one or more CTNet cyclic link.

CTNet Receiving Parameter	Allocation	Destination Parameter
73.00 (_S00%)	CTNet In Mapping Parameter 1	70.60
73.01 (_S01%)	Line Speed	-
73.02 (_S02%)	Line Acceleration	-
73.03 (_S03%)	CTNet In Mapping Parameter 2	70.61
73.04 (_S04%)	CTNet In Mapping Parameter 3	70.62
73.05 (_S05%)	CTNet In Mapping Parameter 5	70.63

9.1.4 CTNet Output Data

To enable common system parameters to be easily read when using CTNet a function is available to send this group of data, (listed below), to a specific CTNet Node or to broadcast to all CTNet node on the network, that can accept cyclic fast data.

Setting Parameter 70.43 to:

- 0 (or if an MD29AN) will disable this function
- 1 Broadcast to all nodes
- >1 Data sent to a specific node address

The CTNet destination registers can be determined by setting the destination start register number in parameter 70.67.

e.g. if parameter 70.67 = 11 then the CTNet destination registers would start at 73.11 and finish at 73.15.

70.67 = n

Data

Winder Parameter	Description	Target Node Receiving registers
72.70	Statusword 1	73.70.n
72.71	Statusword 2	73.71.n+1
71.06	Actual Tension/Dancer Feedback	73.72.n+2
71.01	Actual Diameter	73.73.n+3
71.07	Tension Feed-forward	73.74.n+4

CTNet Output Data Destination Mapping Overview

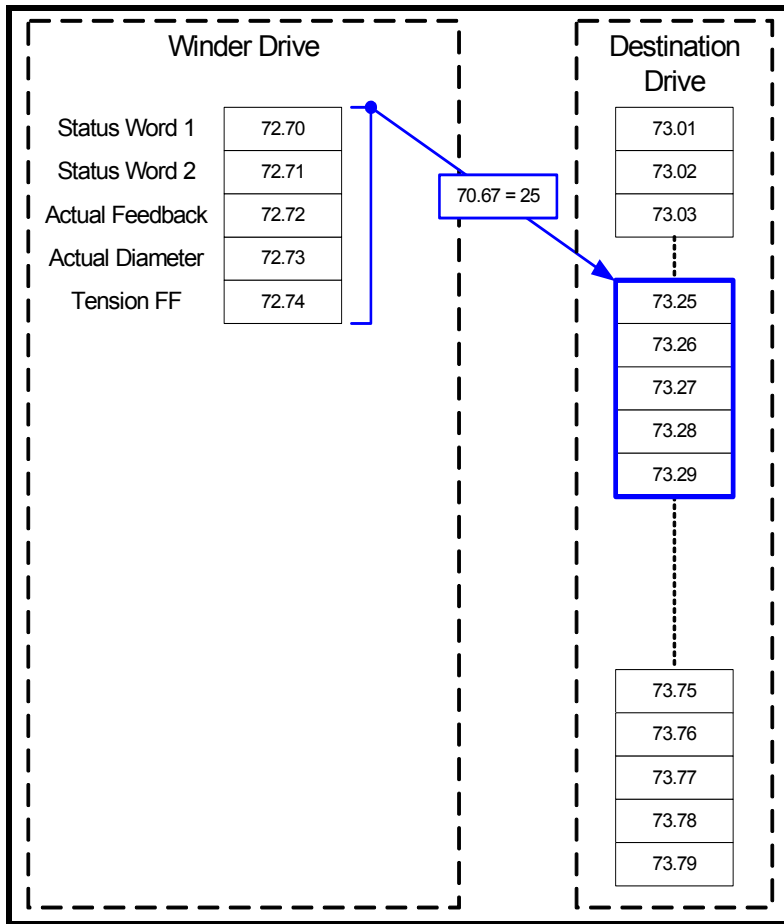

10 Parameter Set-up Tools

There are two parameter tools available on the CD that assists with the drive and application parameter management from the P.C.

- Mentorsoft
- CTNet Browser

10.1 Mentorsoft

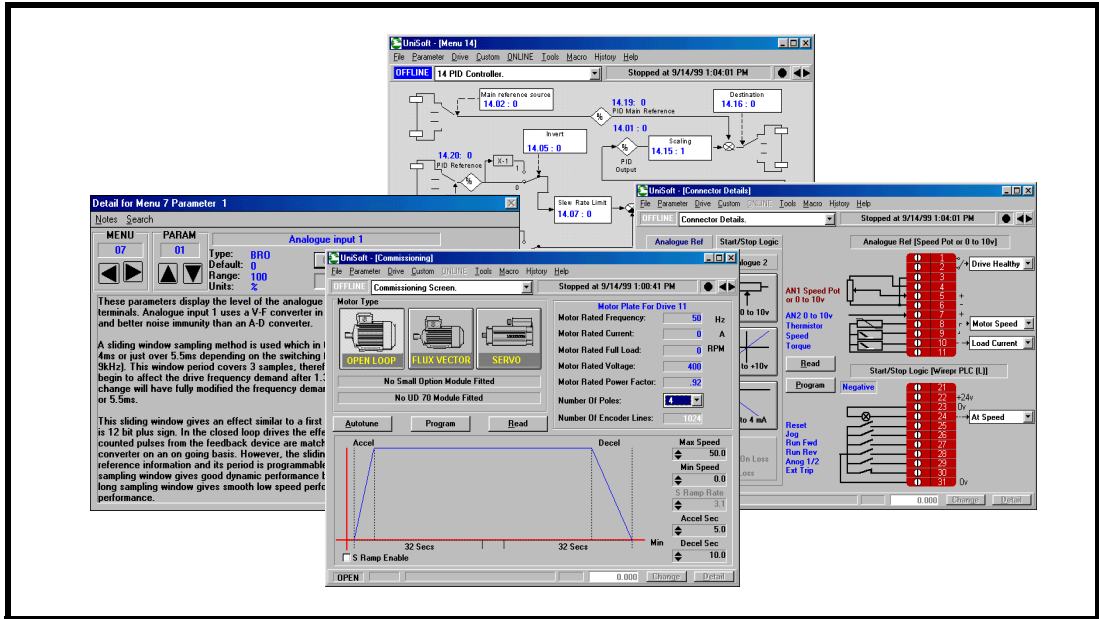

The Mentorsoft programme communicates to the drive via the Application module's RS485 port and has the following features:

- Parameter Upload Download
- Parameter configurations save to file
- Compare
- Custom & Parameter listings
- Graphical representation of the drive menu parameters

10.2 Browser

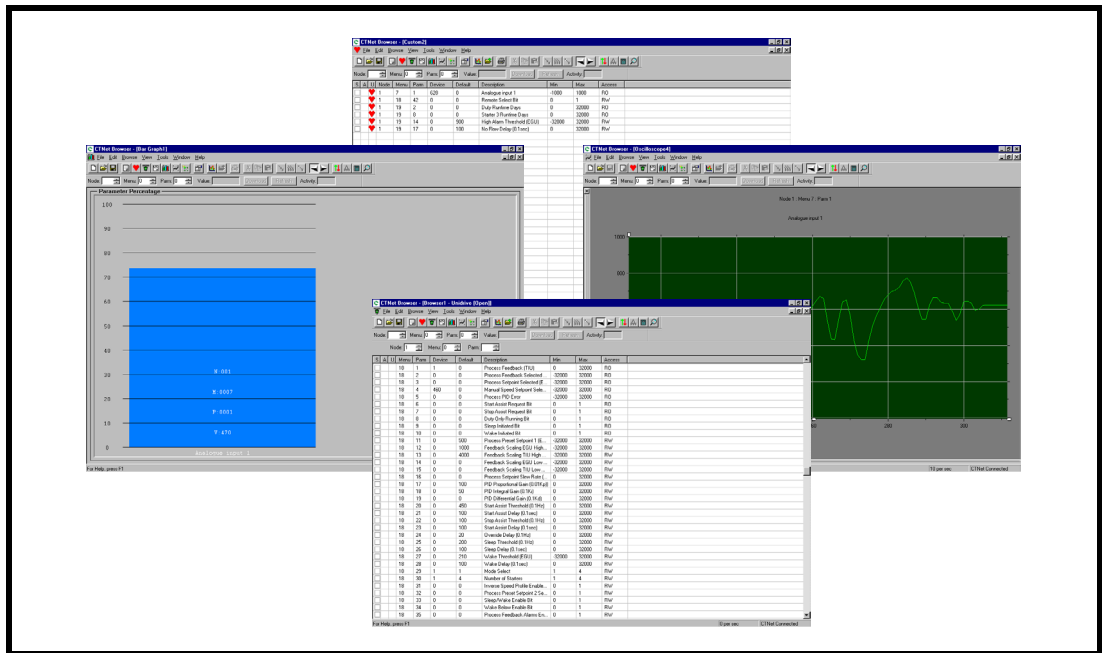

The Browser programme can communicate to the drive via the Application module's RS485 port, or RS232 port or CTNet interface, and has the following features:

- Parameter Upload Download
- Parameter configurations save to file
- Compare
- Custom & Parameter listings
- Network Parameter Management
- Scope and logging

11 CTIU – Operator Panel

11.1 Introduction

The CTIU operator interface enables the user to monitor, set-up and control the winder application remotely reducing the need to use the manual or Mentor parameter numbers. All parameters are displayed in text rather than using it's Mentor or MD29 parameter number. Textual descriptions are also given for trips/alarms, Boolean statuses/settings and selection parameters. On line Help descriptions are available for certain configuration parameters where there function is not clear. The illustrations in this chapter show screen shots from the programming tool and will show characters such as xxx or ### where a numeric or text variable would be expected.

Front View of CTIU110

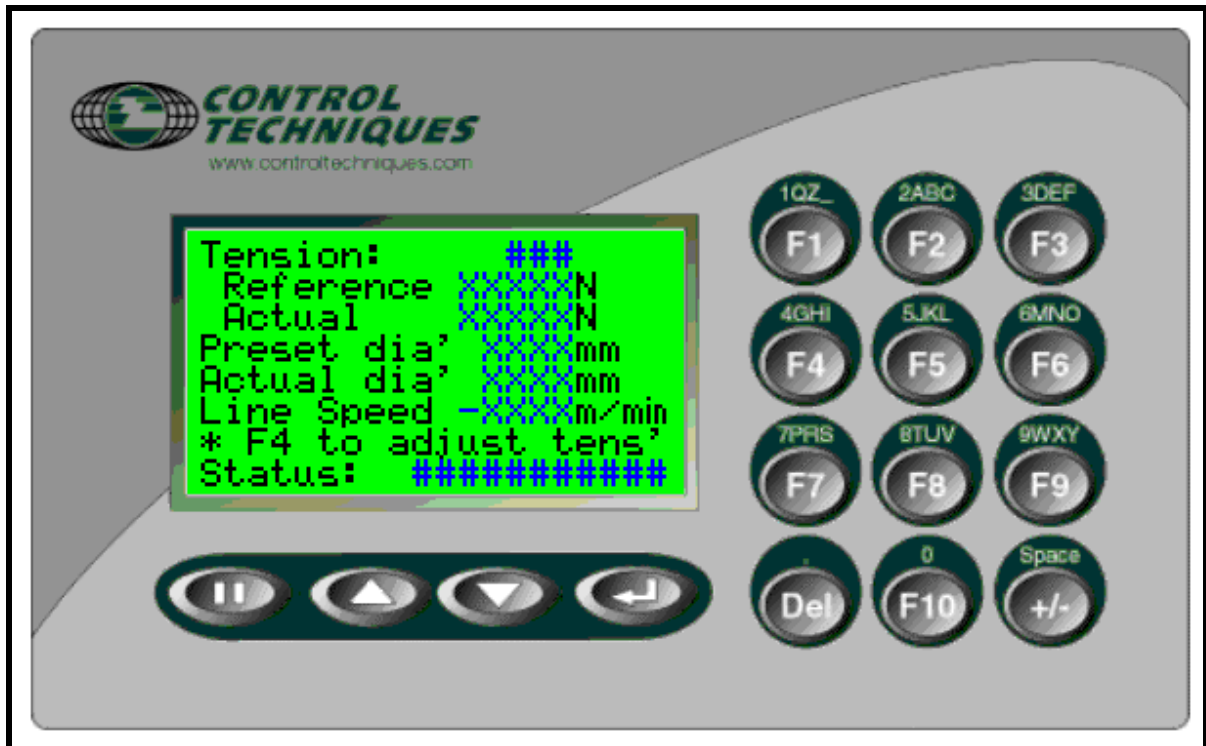

11.2 Software Version

CTIU Software Version – V01.00.00 or greater, this will be displayed on the CTIU second splash screen or can be found under the 'Drive Diagnostics' menu

11.2.1 Configuration file version

There are two configuration files, one for winders operating in metric units, the other for winders operating in imperial units. The appropriate file will be selected by Winflasher 3 if you are using this tool. If you have to download the CTIU configuration files manually then you should choose AC Winder metric.cmc for metric machines of AC Winder Imperial.cmc for imperial machines. If you try to run the metric configuration on an winder control set for imperial or vice versa the CTIU will not operate and will display a warning and recovery message as shown below.

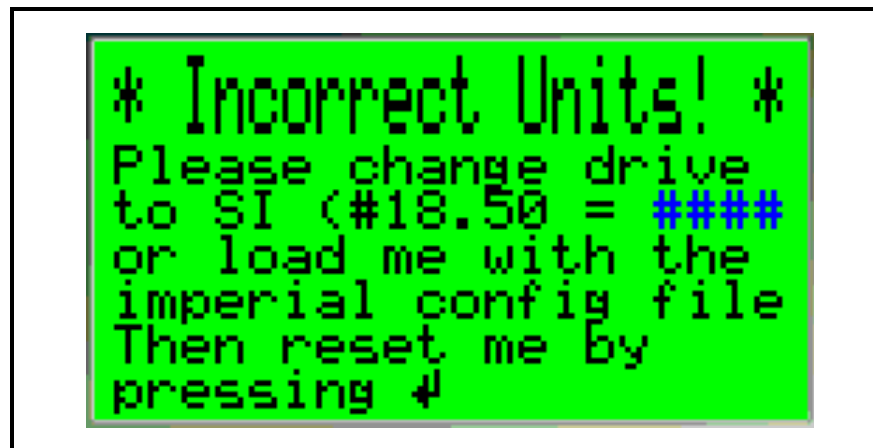

11.3 Mechanical Installation

11.3.1 Panel Cut-out Detail

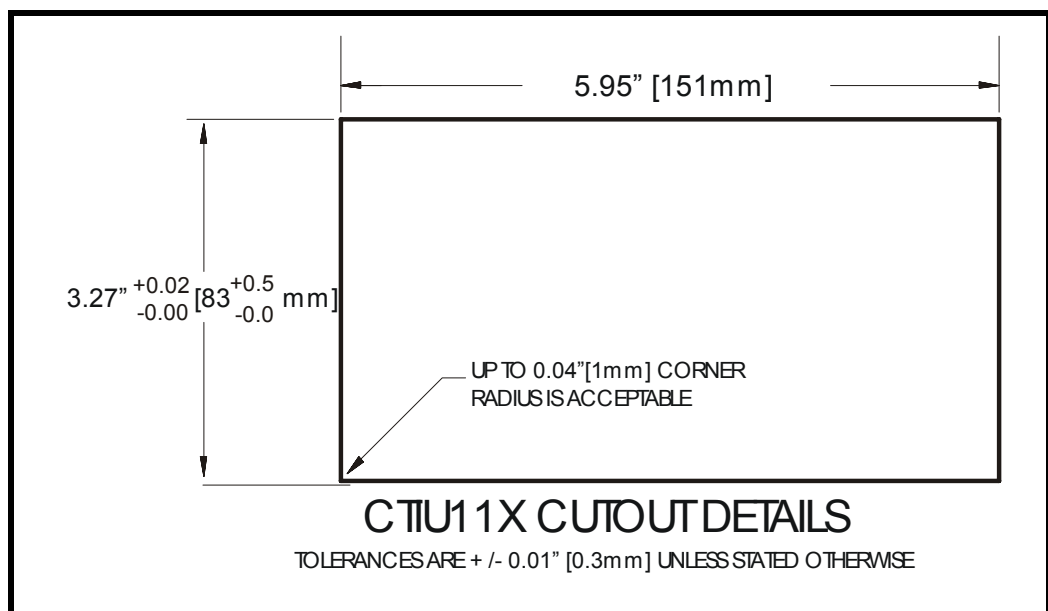

11.4 Electrical Installation

11.4.1 CTIU110 Rear View

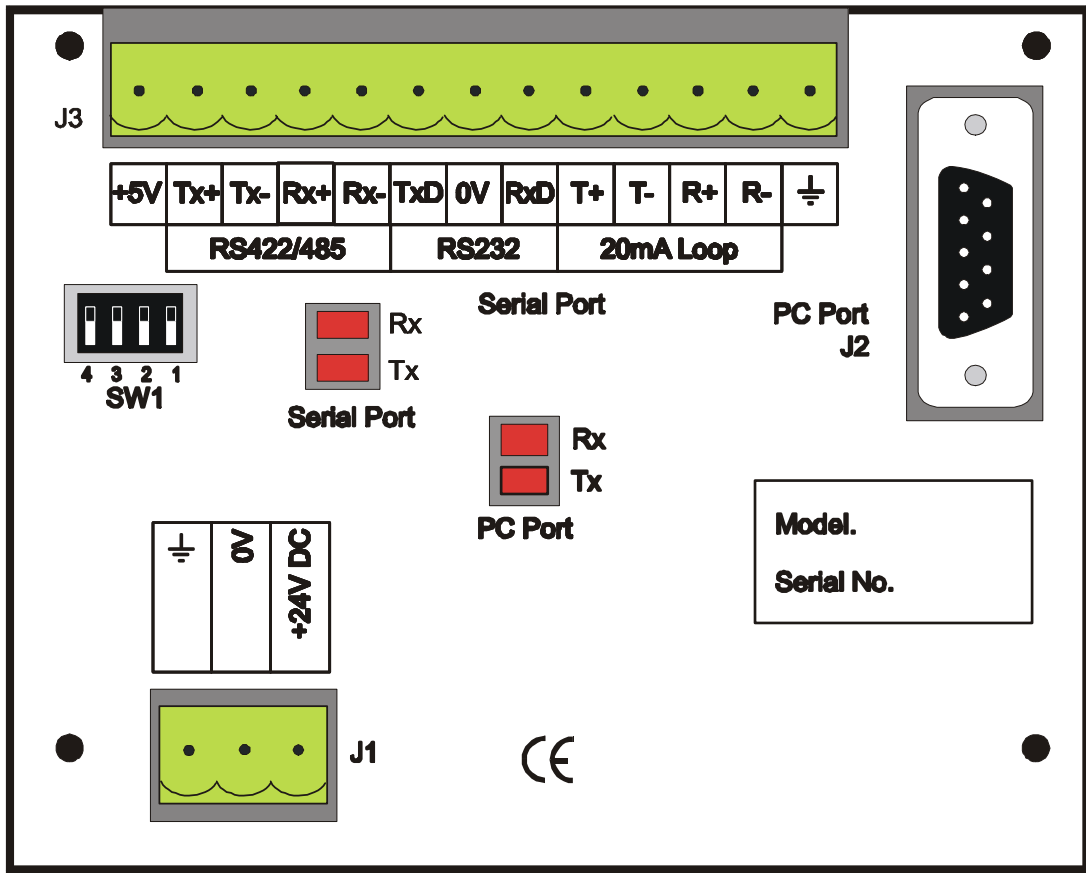

24Vdc Power Supply Requirements (J1)

Peak Inrush – 240mA

Continuous – 100mA

11.4.2 Serial Communications Cable Connections

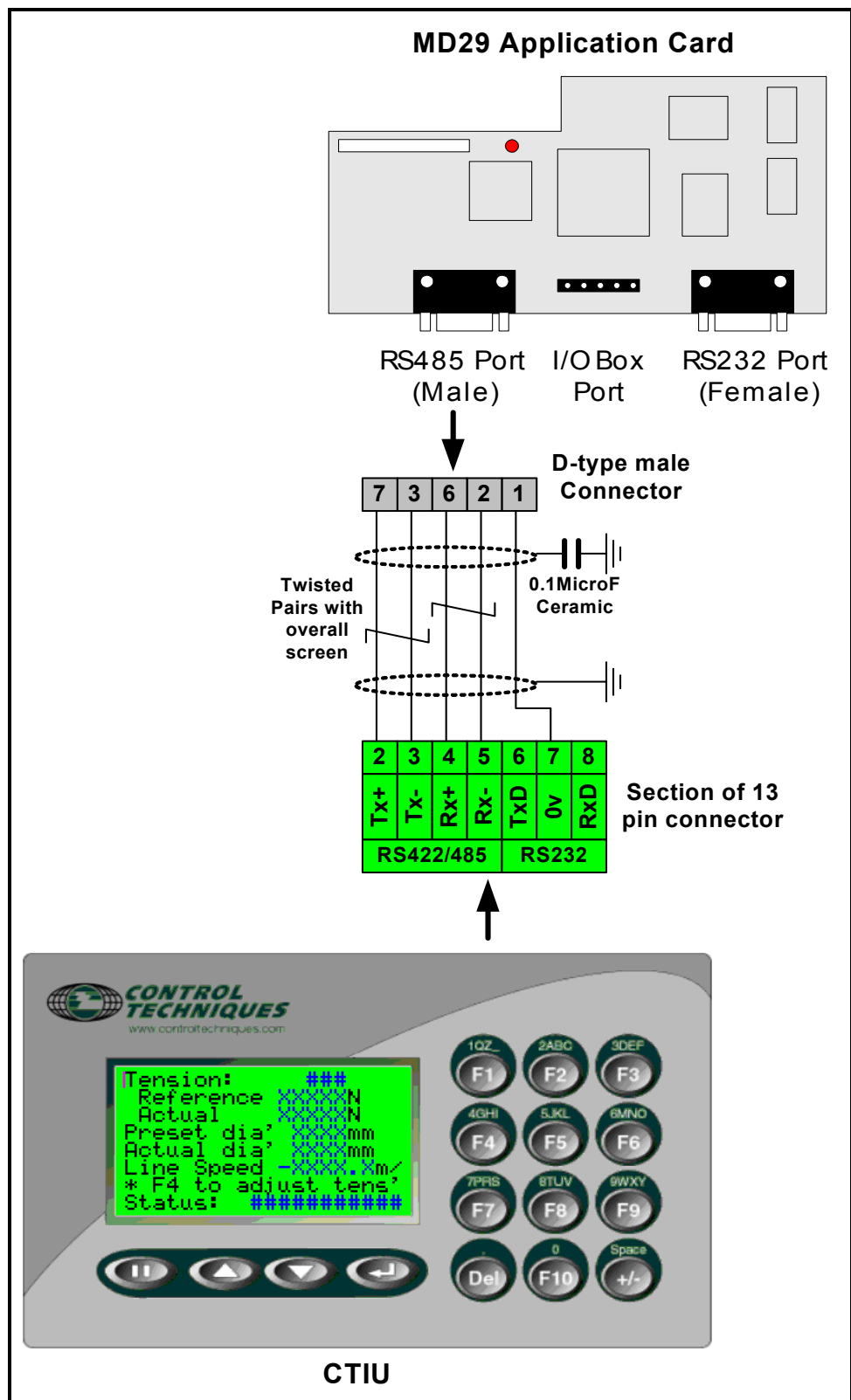

Recommended Cables

Belden No. 8105, 9807 or 9832 – General Purpose

Belden No. 8165 – Heavy Noise Environment

11.5 Mentor set-up

The protocol used between the CTIU110 and the Mentor application module is Modbus RTU. To establish communications the Mentor Address, Baud rate and Protocol is required to be set, the following table details the required parameters to be set:

Parameter	Setting	Description
14.01	11	Drive address
14.02	13	RS458 Modbus-RTU protocol mode
14.03	9600	Baud rate

NOTE Perform a Drive save to save these setting during power down.
e.g. XX.00 = 001 followed by reset.

11.5.1 CTIU110 Configuration of the RS-485 Port

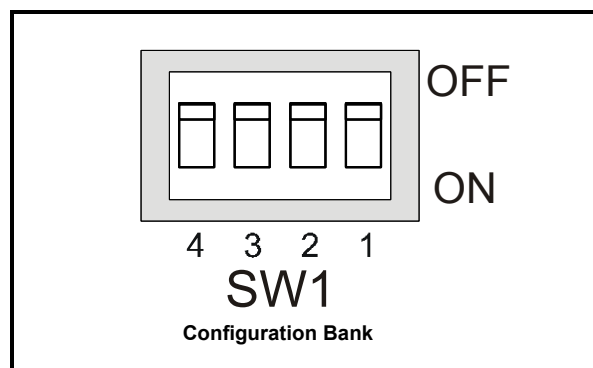

The configuration bank sets the parameters of the RS-485 port as described in Table 4.1.

Configuration Bank Description	
Switch 1	ON: Pull-up (must be used together with switch 3) OFF: no Pull-up
Switch 2	ON: 120Ω termination OFF: no termination
Switch 3	ON: Pull-down (must be used together with switch 1) OFF: no Pull-down
Switch 4	Reserved for future use
NOTE	Switch 1 and 3 must be used together. Either both pull-up and pull-down are used or neither is used.

Pull-up and **Pull-down** switches are used to increase the signal level on the RS-485 bus. This is useful if there is a long bus and a significant amount of attenuation is anticipated.

Termination resistance of 120Ω must be placed across each end of the RS-485 bus. With switch 2 ON, a 120Ω resistance is placed across the bus. This should only be used if the CTIU050/100/110 is the last device at either end of the bus.

11.6 Operation Button Selection Actions

PAUSE key selects data for editing OR exits from data editing.

PAUSE & DOWN keys pressed together, enters sub menu pages.

PAUSE & UP keys pressed together, exits sub menus to the parent menu pages.

UP key selects the previous menu page, sub menu page, alarms, and increments data

DOWN key selects the next menu page, sub menu page, alarms and also decrements data.

ENTER key sends data to the automation equipment, accepts alarms, and displays accepted alarms.

ALPHANUMERIC KEYPAD and **PROGRAMMABLE KEYS** can be used to enter data or can be used to preform some pre-programmed action.

Contrast Adjustment

On menu page 1 (after the start-up screen), hold the **ENTER** key and press the **UP** or **DOWN** key to adjust the contrast. The contrast setting is stored and not lost after removing power.

11.7 Navigation

The winder screens are split into 2 sections:

- Operator section
- Configuration section

The winder parameters are grouped into relevant application menus to aid efficient navigation to each parameter. Each menu has two parts:

- A parent menu page, this is the menu header and displays the menu description.
- Sub-menu page/s containing all the relevant parameters for the selected menu.

For example - Parent Menu Page: I/O Diagnostics

Sub-menu Pages contain relevant parameter for the Parent Menu:

All status of the Digital Inputs and Outputs Terminals: 1&2 and 24-30.

The current values on all Analogue input terminal: 05-08.

Using on-screen graphical icons the following sections describe how to navigate between Parent and sub-menu screens.

11.7.1 Parent Menu Pages Navigation

Parent Menu Page UP
This signifies the parent menu navigation direction. When this symbol is shown, pressing the 'Up' key will display the next parent menu page up from the current.

Parent Menu Page Down
This signifies the parent menu navigation direction. When this symbol is shown, pressing the 'Down' key will display the next parent menu page down from the current.

Sub-menu Access
This indicates the two keys that need to be pressed to access the Parent sub-menu.
e.g. to access the Process Diagnostic sub-menu pages, press the Pause and Down keys together.

11.7.2 Sub Menu Pages Navigation

Parent Menu Access
Press the Pause and the Up keys together to go back to the Parent menu page. This will be indicated on the last page on each sub-menu

Sub-menu Page UP
This signifies the sub-menu navigation direction. When this symbol is shown, pressing the 'Up' key will display the next sub-menu page up from the current.

Sub-menu Page Down
This signifies the sub-menu navigation direction. When this symbol is shown, pressing the 'Down' key will display the next sub-menu page down from the current.

Help
Many of the configuration sub-menu pages are provided with a brief help description for each parameter. Pressing the F10 key will display the help information for the parameters displayed on the current sub-menu page .

11.8 Operators Screens Description

The operator screens consist of:

- Top-level main page which provides an overview of all the important parameters of the winder on one screen
- Diagnostic information for drive and the application
- Process set points.

These screens are detailed in the Operators navigation diagram shown below.

11.8.1 Top Level Screen and Functionality

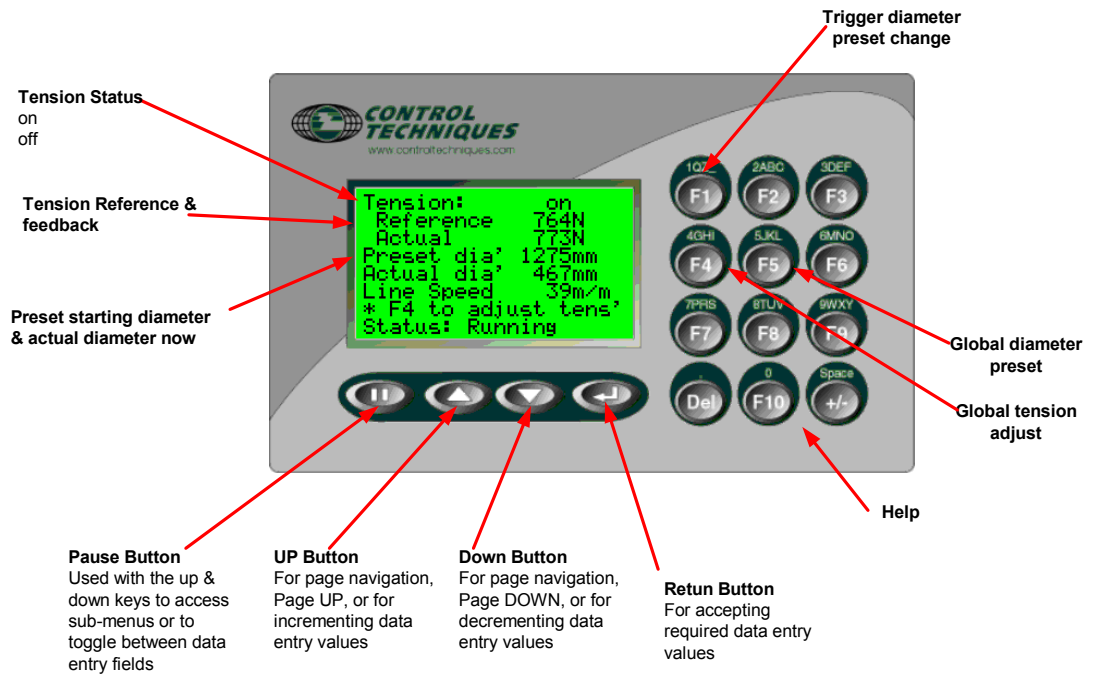

The top-level screen indicates the major process variables for the winder. The Top-level screen is always the first menu Page to be displayed. A Menu Timeout, safety feature is used to force the CTIU display focus back to the first (main) menu page if no activity (key presses) occur for 30 seconds.

11.8.2 Diagnostic Screens

The following diagnostic screens are available:

Winder Diagnostics - Displays parameters directly related to the winder control such as settings, feedbacks, errors.



Drive Diagnostics - Displays parameters directly related to the drive, Power, Speed, DC Bus Volts, Current, Overload accumulator, etc; Fault log; Software versions.



I/O Diagnostics - Displays parameters directly related to the drive inputs & outputs, Unidrive standard and option digital status's and analogue current values, reference flow is also shown.



11.9 Splash Screens

There are two splash screens displayed in sequence during initial power up. These detail the application and software version information.

11.9.1 Application Page (1st Page)



11.9.2 Software Version Page (2nd Page)

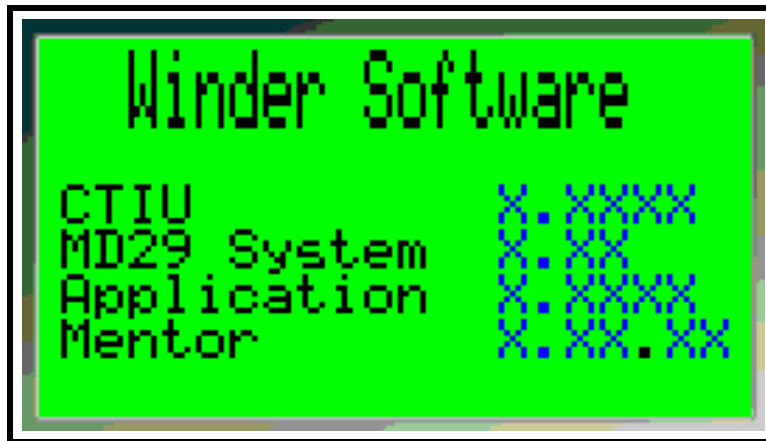

11.10 Parameter Save

When any of the editable data fields has been changed within the configuration menus and the Top-level menu page (1) is display (due to timeout, or forced by the user), a parameter save will be prompted to the operator.

11.10.1 Parameter Save Main Screen

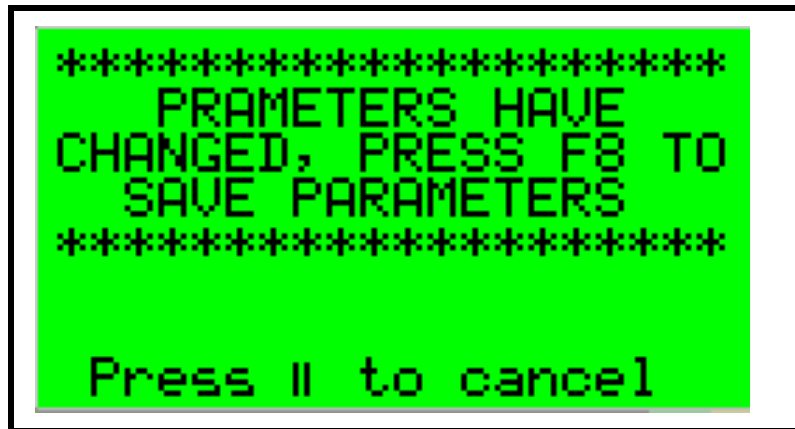

This is the first screen to be displayed, where it indicates to the user to save parameters by pressing Function key F5. To save the parameters the Unidrive must be in stopped state, a flashing message will advise if a save can be performed.

For example: Flashing Message

Drive Running – Stopped OK to Save

Drive Stopped – Running cannot save

If a parameter save is not required the pause (||) key can be press to quit back to the Top-level menu page (1).

11.10.2 Parameter Save Acknowledgement Screen



When function key F5 is press with the Drive stopped the above screen will appear acknowledging a parameter save is being performed. After approximately 5 seconds the top level menu page (1) will re-appear, confirming the save has completed. Two other screens will warn if the save action fails.

11.11 Trip & Alarm indication

There are 4 Alarm pages:

- Drive Trip – Indication the winder drive has tripped and needs a reset to resume operation. (Unless the result of the trip has caused permanent damage) The trip reason will be decoded and displayed on the screen. The user is offered the facility to reset the drive
- Diameter calculation error – The software has detected an anomaly in the diameter calculation, non-resettable.
- Web Break Detected – The software has detected a web break, non-resettable.
- Watchdog - The Winder Control Software watchdog has tripped, probably due to a communications failure, non-resettable.

All pages have to be acknowledged by the pressing of the 'Return' key. This will remove the Alarm page from the display only; this will not reset any trips or alarms on the drive. A drive trip can be reset from the CTIU (F3 key), or from another source (Pushbutton, Drive control panel, line controller etc). When an alarm is acknowledged but not reset, the Alarm page will be removed from the display of the CTIU.

The non-resettable conditions will require intervention for maintenance staff.

11.11.1 Alarm Pages



Drive tripped
Fault:

Press:
F3 to reset drive
↓ to acknowledge

Trip Description
Text table with reference to Unidrive parameter #10.20

Reset Drive

Acknowledge
Press Return Key. This will not reset fault.

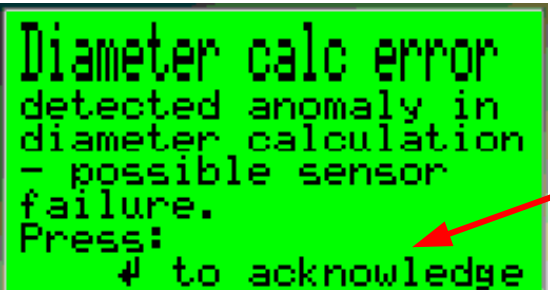

Diameter calc error
detected anomaly in
diameter calculation
- possible sensor
failure.
Press:
↓ to acknowledge

Acknowledge
Press Return Key. This will not reset fault.



Web break detected

Press:
↓ to acknowledge

Acknowledge
Press Return Key. This will not reset fault.



Control watchdog

Press:
↓ to acknowledge

Acknowledge
Press Return Key. This will not reset fault.

11.12 CTIU Function Keys Allocation

11.12.1 Global Control Function Keys

The following Function keys are always available on any screen. These functions allow the winder tension and preset diameter to be quickly accessed and adjusted.

F4 – Tension Adjust. displays a page providing fast & immediate spin button adjustment of tension, using the up & down keys.

F5 – Diameter adjust, displays a page providing fast & immediate spin button adjustment of diameter, using the up & down keys. F1 must be pressed to load the new diameter

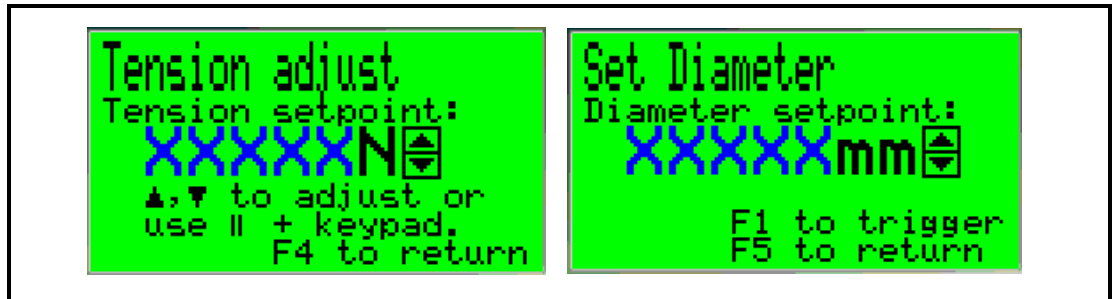

11.12.2 Local Function Keys

The following are defined as local function keys as they only apply to one or range of pages.

- F1 – Trigger diameter preset change.
- F3 – Drive reset available on I/O setup pages and the drive trip alarm page.
- F8 – Parameter save offered automatically when drive parameters have been changed.
- F10 – Help a few pages have descriptive helps aimed at clarifying obscure parameter use.

12 Quick Reference

12.1 Mentor

12.1.1 Relevant Parameter

01.01	Speed Reference value
01.05	Motor Base Volts
01.06	Maximum Forward Speed Clamp
01.07	Minimum Forward Speed Clamp
01.08	Maximum Reverse Speed Clamp
01.09	Minimum Reverse Speed Clamp
01.10	Bipolar reference select
01.11	Reference enabled indicator
01.14	Preset selector
01.15	Preset selector
01.17	Maximum Diameter
01.19	Preset diameter 2
02.01	Post ramp speed reference
02.02	Ramp Enable
02.04	Forward Acceleration Time
02.05	Forward Deceleration Time
02.06	Reverse Acceleration Time
02.07	Reverse Deceleration Time
02.08	PID - P gain
02.09	PID - I gain
02.10	PID - D gain
02.11	PID - Limit
02.12	PID - Filter
03.04	Armature voltage
03.12	Select Encoder Feed back
03.14	Encoder scaler
04.01	Motor current reference
04.02	Motor current final reference
04.04	Symmetrical Current Limit
04.11	Select Torque feed forward (Loss & Inertia compensation)
04.12	Drive mode bit 1
04.13	Drive mode bit 2
05.01	Armature current
05.17	Drive firing inhibit
05.18	Standstill logic enable
05.23	Current loop hysteresis
06.07	Field controller spill over voltage set point in standard mode
06.08	Field controller current reference in Back EMF mode
10.09	Drive Zero Speed
10.12	Drive healthy
10.35	Drive User Reset
13.08	Centring Acceleration rate
13.09	Centring Speed
13.10	Position controller enable
13.12	Bit 10 of Control word 1 (73.70.10) use for remote switching
13.14	Encoder lines per rev
11.11	Serial comms. address
11.12	Serial comms. baud rate selector
11.13	Serial comms. mode selector

12.1.2 I/O Parameters

Standard Mentor I/O

No.	Description	Term.
07.01	Analogue Tension reference Indication	4
07.02	Analogue Taper reference Indication	5
07.03	Analogue Diameter reference Indication	6
07.04	Analogue Load cell or Dancer Indication	7
07.05	Analogue Line Speed reference Indication	3
07.11	Analogue input 1 destination	
07.12	Analogue input 2 destination	
07.13	Analogue input 3 destination	
07.14	Analogue input 4 destination	
07.15	Analogue input 5 destination	
07.20	Draught or Slip factor for line speed reference	
08.01	Digital input / Run permit	21
08.02	Digital input / Inch reverse	22
08.03	Digital input / Inch forward	23
08.04	Digital input F4 state indicator	24
08.05	Digital input Line run	25
08.06	Digital input F6 state indicator	26
08.07	Digital input F7 state indicator	27
08.08	Digital input F8 state indicator	28
08.09	Digital input F9 state indicator	29
08.10	Digital input F10 state indicator	30
08.11	Digital input Drive Enable	31
08.21	Disable normal logic	
13.12	Echoes bit 10 of Control Word 1 (use for remote contactor control)	

12.2 Application

12.2.1 Mentor Parameters Used as Application Parameters

No.	Description	Type	Units	Range	Default	Setting
01.05	Motor Base voltage	RW	Volts	0 - 1000	0	
01.17	Maximum diameter	RW	mm <i>0.1"</i>	15.16- 1000	1	
01.19	Preset2 diameter value	RW	mm <i>0.1"</i>	0 - 1000	1	
02.08	PID control P gain	RW	0.001Kp	0-1999	0	
02.09	PID control I gain	RW	0.1Ki	0-1999	0	
02.10	PID D Gain	RW	0.1Kd	0- 1999	0	
02.11	Limit on PID output	RW	Tension-% Speed-cm/min <i>0.01in/min</i>	0-100.0 0-1999	0	
02.12	PID Filter	RW	-	0-32000	0	
04.11	Select compensation torque	RW	Bit	0-1	0	
07.01	Tension reference Analogue format	RW	PU	0-1000	0	
07.02	Taper reference Analogue format	RW	PU	0-1000	0	
07.03	Preset Diameter Analogue format	RW	PU	1-1000	1	
07.04	Load cell / Dancer feedback	RW	PU	0-1000	0	
07.05	Line Speed reference Analogue format	RW	PU	0-1000	0	
07.20	Line Speed Slip factor	RW	0.1%	100-2000	1000	
08.02	Inch reverse command bit	RW	Bit	0-1	0	
08.03	Inch Forward command bit	RW	Bit	0-1	0	
08.05	Run forward command bit	RW	Bit	0-1	0	
13.08	Centring Acceleration	RW	CM/M/S <i>ins/min/s</i>	0-255	0	
13.09	Centring Speed	RW	m/min <i>ft/min</i>	0-255	0	
13.12	Contactora control bit	RO	Bit	Repeats 73.70.10	0	
13.10	Locks out position controller	RO	Bit	0	0	

12.2.2 Menu 15

No.	Description	Type	Units	Range	Default	Setting
15.01	Current Radius display	RO	mm <i>0.1"</i>	Min – Max radius	-	
15.02	Preset Radius value	RO	mm <i>0.1"</i>	Min–Max radius	-	
15.03	Required tension as per unit value use for E/P output	RO	PU	0-1000	-	
15.04	Line Speed	RO	m/min <i>ft/min</i>	0–Max line speed	-	
15.05	Winder Speed	RO	r/min	0-1999	-	
15.06	Motor base Speed	RW	r/min	1-32000	1	
15.07	Motor base Power	RW	0.1kW <i>0.1hp</i>	1-32000	1	
15.08	Motor base current	RW	Amps	0-1999	0	
15.09	Drive maximum current	RW	Amps	0-1999	0	
15.10	Gear ratio	RW	0.01 (16.29=0) 0.1 (16.29=1)	100-1999 10 -1999	100	
15.11	Diameter Hold function speed threshold	RW	r/min	1-255	0	
15.12	Offset speed	RW	m/min <i>ft/min</i>	0–255	0	
15.13	Percentage of Tension applied as Stall Tension	RW	%	0-100	0	
15.14	Manual slew rate multiplier	RW	Multiplier	0-255	1	
15.16	Minimum diameter	RW	mm <i>0.1"</i>	1-255	1	
15.17	Preset1 diameter value	RW	mm <i>0.1"</i>	0-255	1	
15.18	Material gauge Hi	RW	Microns*100 <i>0.001" *100</i>	1-255	1	
15.19	Material gauge Lo	RW	Microns <i>0.001"</i>	0-255	1	
15.20	Application Config see below	RW		0-255	0	
15.20.0	Select serial input for Line Speed reference	RW	Bit	0-1	0	
15.20.1	Diameter Calculation Mode	RW	Bit	0-1	0	
15.20.2	Select Dancer or Load cell feedback	RW	Bit	0-1	0	
15.20.3	Set stall tension as percentage of Maximum tension	RW	Bit	0-1	0	
15.20.4	Select fixed diameter slew limit	RW	Bit	0-1	0	
15.20.5	Select acceleration signal	RW	Bit	0-1	0	
15.20.6	Watch dog enable	RW	Bit	0-1	0	
15.20.7	Enable Back EMF winder mode	RW	Bit	0-1	0	

15.22	Select Diameter Set Point from MMI via 15.17 or 11.19	RW	Bit	0-1	0	
15.24	Enable Acquire	RW	Bit	0-1	0	
15.25	Select direct measurement of diameter via analogue input	RW	Bit	0-1	0	
15.26	Select Over or Under winding direction	RW	Bit	0-1	0	
15.27	Enable Slack Web detection	RW	Bit	0-1	0	
15.28	Preset diameter command bit	RW	Bit	0-1	0	
15.29	Select to operate as an Unwind	RW	Bit	0-1	0	
15.30	Select second preset diameter 1.19 or 70.52	RW	Bit	0-1	0	
15.31	PID Enable	RW	Bit	0-1	0	
15.32	PID Hold integral	RW	Bit	0-1	0	
15.33	PID Reset integral	RW	Bit	0-1	0	
15.34	Select Speed Mode of operation	RW	Bit	0-1	0	
15.35	Diameter calculation error flag	RO	Bit	0-1	0	
15.36	Web break error flag	RO	Bit	0-1	-	
15.37	Enable coupling function	RW	Bit	0-1	0	
15.39	PID Output	RO	cm/min <i>0.1ft/min</i>	0-255		
15.40	Diameter Hold Flag	RO	Bit	0-1	-	
15.50	Maximum motor speed HI	RO	RPM * 100	0-255		
15.51	Maximum motor speed LO	RO	RPM	0-255		

12.2.3 Menu 16

No.	Description	Type	Units	Range	Default	Setting
16.01	Tension torque current	RO	Amps	0-1999	-	
16.02	Compensation current	RO	Amps	0-1999	-	
16.03	PID error	RO	TorquePU Speed pos	+/-1000 +/-1999	-	
16.04	Final Speed Reference	RO	m/min ft/min	0-1999	-	
16.05	Acceleration rate	RO	m/min/s ft/min/s	0-1999	-	
16.06	Material width	RW	mm 0.1ins	1-32000	1	
16.07	Material density	RW	kgms/m ³ /10 lb/ft ³ /10	1-255	1	
16.08	Mandrel inertia	RW	kgms/m ² lb.ft ²	0-255	0	
16.09	Maximum line speed	RW	m/min ft/min	1-1999	1	
16.10	Maximum Tension in Newtons Base	RW	N lbf	1-1999	1	
16.11	Maximum Tension in Newtons Multiplier	RW	N	1-255	1	
16.12	Centring Window	RW	-PU	0-255	0	
16.13	Fixed value for Diameter slew rate	RW	Microns per sec	1-255	1	
16.14	Thread/Inch speed	RW	m/min ft/min	0-255	0	
16.15	Friction loss	RW	0.1%	0-255	0	
16.16	Viscous loss	RW	0.1%	0-255	0	
16.17	Diameter at which Taper Tension will start	RW	mm 0.1"	0-255	1	
16.18	Tension reference ramp time	RW	0.1s	0-255	1	
16.19	Motor inertia	RW	kg.m ² lb.m ²	0-255	0	
16.20	Dancer Position Set point	RW	-	0-255	0	
16.21	Select Torque Memory	RW	Bit	0-1	0	
16.22	Enable Lay On Tension boost	RW	Bit	0-1	0	
16.23	Enable Index Tension boost	RW	Bit	0-1	0	
16.24	Enable Speed Boost	RW	Bit	0-1	0	
16.25	Reverse direction of diameter change under Lap or Traverse	RW	Bit	0-1	0	
16.26	Signal Traverse reversal	RW	Bit	0-1	0	

16.27	Select Traverse mode for diameter calculation	RW	Bit	0-1	0	
16.28	Hyperbolic Taper select	RW	Bit	0-1	0	
16.29	Gear Ratio x10 multiplier	RW	Bit	0-1	0	
16.30	Speed reference polarity	RO	Bit	0-1	-	
16.31	Select the form of engineering units for set up data	RW	Bit	0-1	0	
16.32	Select condition which switches from Stall to Run tension	RW	Bit	0-1	0	
16.33	Hold diameter command bit	RW	Bit	0-1	0	
16.34	Quantum Select	RW	Bit	0-1	0	
16.35	Web Tensioned Flag	RO	Bit	0-1	-	
16.36	Watch dog trip	RO	Bit	0-1	-	
71.05	Motor Speed	RO	r/min	0-2 ³²	-	
71.06	Actual Tension	RO	N lbf	0–Max tension	-	
71.07	Tension feed forward	RO	N lbf	0–Max tension	-	

12.2.4 Menu 70

No.	Description	Type	Units	Range	Default	Setting
70.00	Maximum Tension	RW	N <i>lbf</i>	0-2 ³²	0	
70.01	Maximum Line Speed	RW	m/min <i>Ft/min</i>	0-2 ³²	0	
70.02	Width (Alternative register)	RW	mms <i>0.1ins</i>	0-2 ³²	0	
70.03	Density (Alternative register)	RW	kgms/m ³ <i>lb/ft³</i>	0-2 ³²	0	
70.04	Minimum Diameter	RW	mms <i>ins</i>	0-2 ³²	0	
70.05	Maximum Diameter (Alternative register)	RW	mms <i>ins</i>	0-2 ³²	0	
70.06	Armature resistance (Alternative register)	RW	milli Ohms	0-2 ³²		
70.07	Gauge (Alternative register)	RW	Microns <i>0.001"</i>	0-2 ³²	0	
70.08	Digital Tension Reference	RW	N <i>lbf</i>	0–Max Tension	0	
70.09	Digital Taper Reference	RW	Percent	0-100		
70.08	Tension Set point (Digital)	RW	N <i>lbf</i>	0-Max tension	0	
70.09	Taper Set point (Digital)	RW	%	0-100	0	
70.10	Select alternative set up registers 70.00 – 70.07	RW	Bit	0-1	0	
70.11	Select Tension Set Point from MMI via 70.08	RW	Bit	0-1	0	
70.12	Select Taper set Point from MMI via 70.09	RW	Bit	0-1	0	
70.13	Select Alternative PID set up from MMI via 70.14 – 70.16	RW	Bit	0-1	0	
70.14	PID P term	RW	0.001Kp	0-2 ³²	0	
70.15	PID I term	RW	0.1Ki	0-2 ³²	0	
70.16	PID D term	RW	0.1Kd	0-2 ³²	0	
70.19	Length count	RW	Metres <i>feet</i>	0-2 ³²	0	
70.20	Watchdog Clock Time	RW	0.01sec	0-2 ³²	0	
70.21	Watchdog trip delay	RW	0.1sec	0-2 ³²	0	
70.22	Winder Speed Sample Time	RW	mS	10-10000	10	
70.23	Analogue Line speed signal acceleration sample time	RW	10mS	1-100	1	
70.24	Index tension boost	RW	0.1% actual tension	0–1000	0	

70.25	Lay On tension boost	RW	0.1% max tension	0-000	0	
70.26	Speed Boost value	RW	m/min ft/min	-/+ 0% of max line speed	0	
70.27	Select encoder line speed reference	RW	Bit	0-1		
70.28	Line encoder PPR	RW	PPR	0-2 ³²	0	
70.29	Line encoder time base	RW	millisecs	10-10000	100	
70.30	Line encoder RPM	RW	RPM	0-2 ³²		
70.32	Slack Web detection threshold	RW	0.1 percent	0-1000		
70.33	Acquire Diameter multiplier	RW	Per Unit	1-1000		
70.34	Enable Acquire on Start	RW	Bit	0-1		
70.35	Coiler Offset (Alternative register)	RW	m/min ft/min	0-Max Speed	0	
70.36	Lower limit for diameter hold on slew rate	RW	μm/s (0.001ins/s)	0-2 ³²	200	
70.37	Lower speed limit of PID gain profiler	RW	Percent of Max speed	0-100	10	
70.38	Reset length count	RW	Bit	0-1	0	
70.40	Coupling speed reference	RW	r/min	0-10	0	
70.41	Coupling Current Limit Value	RW	%	0-1000	1000	
70.42	At Line Speed acceptance window Value	RW	0.1m/min (0.1ft/min)	0-Max speed	0	
70.43	CTNET Output Data Select	RW	-	-1 to 255	0	
70.49	Software Version Number	RO		0-2 ³²		
70.51	Preset diameter 1 (Alternative register)	RW	mm 0.1"	0-2 ³²		
70.52	Preset diameter 2 (Alternative register)	RW	mm 0.1"	0-2 ³²		
70.53	Select 70.51 & 70.52 as preset diameter sources	RW	Bit	0-1		
70.54	Toque demand	RO	PU	0-1000		
70.55	Loss Profiler Pointer	RO	-	0-10	-	
70.56	Field Profiler Pointer	RO	-	0-10	-	
70.57	Analogue diameter signal min. value	RW	PU	0-[70.58]	0	
70.58	Analogue diameter signal max. value	RW	PU	[70.58] - 1000	1000	
70.60	CTNet Mapping. Parameter 1 (From_S00% to (73.00))	RW	-	100-9999	100	
70.61	CTNet Mapping. Parameter 2 (From_S03% to (73.03))	RW	-	100-9999	100	
70.62	CTNet Mapping. Parameter 3 (From_S04% to (73.04))	RW	-	100-9999	100	

70.63	CTNet Mapping. Parameter 4 (From_S05% to (73.05))	RW	-	100-9999	100	
70.67	CTNet Out Destination start register	RW	-	1-75	70	
70.70 - 70.79	Loss profiling table, motor speed values	RW	-	0 - Max Motor RPM [71.08]	0	
70.80 - 70.89	Loss profiling table, diameter values	RW	-	Min to max diameter	0	
70.89 - 70.99	Non volatile store for actual diameter	RO	-	Min to max diameter	0	

12.2.5 Menu 71

No.	Description	Type	Units	Range	Default	Setting
71.01	Current Diameter display 2 * 15.01	RO	mm 0.1"	Min – Max radius	-	
71.02	Preset Diameter value 2 * 15.02	RO	mm 0.1"	Min – Max radius	-	
71.03	Line Speed reference equivalent 15.04	RO	m/min ft/min	0 – Max line speed	-	
71.04	Final Line Speed reference equivalent 16.04	RO	m/min ft/min	0 – Max line speed	-	
71.05	Motor Speed	RO	r/min	0-2 ³²	-	
71.06	Actual Tension	RO	N lbf	0–Max tension	-	
71.07	Tension feed forward After taper and ramp	RO	N lbf	0-Max tension	-	
71.08	Maximum motor speed	RO	r/min		-	
71.09	Final Tension reference before taper	RO	N	0-Max tension	-	
71.10	Initial Tension reference after taper	RO	N	0-Max tension	-	
71.11	Actual Slew rate limit Applied	RO	Microns/sec	0–2 ³²	-	
71.12	Calc. Diameter before slew	RO	mm 0.1"	0–2 ³²	-	

12.3 Categorised Winder Parameters

12.3.1 Common Parameters

General

No.	Description	Type	Units	Range	Default	Setting
16.31	Select the form of engineering units for set up data	RW	Bit	0-1	0	
15.26	Select Over or Under winding direction	RW	Bit	0-1	0	
15.29	Select to operate as an Unwind	RW	Bit	0-1	0	
15.20.2	Select feed back from Dancer or Load cell (Speed mode)	RW	Bit	0-1	0	
70.10	Select Set Up Data from Menu 70 sources	RW	Bit	0-1	0	
16.09	Maximum line speed	RW	m/min (ft/min)	1-1999	1	
70.01	Maximum line speed (Alternative register)	RW	m/min (ft/min)	1-2 ³²	1	
07.20	Line Speed Slip factor	RW	0.001%	100-2000	1000	
15.20.0	Select serial input for Line Speed reference via 73.01	RW	Bit	0-1	0	
07.05	Line Speed reference Analogue format	RW	PU	0-1000	0	
73.01	Line Speed Reference (Serial)	RW	PU	(+-16000)	0	
73.02	Line Acceleration Reference (Serial)	RW	PU	(+-16000)	0	
15.10	Gear ratio	RW	0.01 16.29=0) 0.1 (16.29=1)	100-1999 10 -1999	100	
16.29	Gear Ratio x10 multiplier	RW	Bit	0-1	0	
15.18	Material gauge High part	RW	µm (0.001ins)	1-255*100 Alternative see below	1	
15.19	Material gauge Low part	RW	µm (0.001ins)	1-255	1	
70.07	Material gauge(Alternative register)	RW	mm (0.001ins)	1-2 ³²	1	
15.06	Motor base Speed		r/min	1-1999	1	
15.07	Motor base Power	RW	0.1kW (0.1hp)	1-1999	1	
15.08	Motor full load current	RW	Amps	1-1999	1	
01.05	Motor base voltage	RW	Volts	1-1000	1	
15.09	Drive maximum current	RW	Amps	1-1999	1	
15.20.7	Select back EMF mode	RW	Bit	0-1	0	
15.14	Manual Slew Rate Multiplier	RW	Multiplier	0 - 255	1	
16.14	Thread/Inch speed	RW	m/min (ft/min)	0-255	1	

16.21	Select Torque Memory mode	RW	Bit	0-1	0	
16.24	Enable Speed Boost	RW	Bit	0-1	0	
70.26	Speed Boost value	RW	%	(+/-10%) of Maximum line speed	0	
70.27	Select encoder line speed reference	RW	Bit	0-1		
70.29	Line encoder time base	RW	milliseconds	10-10000	100	
70.30	Line encoder RPM	RW	RPM			
13.14	Motor Encoder PPRx10	RW	PPR	65535	0	
70.28	Line encoder PPR	RW	PPR	0-2 ³²	0	
70.19	Length of material wound	RW	m (ft)	0-2 ³²	0	
70.38	Preset length count	RW	Bit	0-1	0	
15.20.6	Watch dog enable	RW	Bit	0-1	0	
70.20	Watchdog Clock Time	RW	0.01s	0-2 ³²	0	
70.21	Watchdog trip delay	RW	0.1s	0-2 ³²	0	
16.04	Final Speed Reference	RO	m/min (ft/min)	0-1999	-	
71.04	Final Speed Reference	RO	m/min (ft/min)	0-2 ³²		
15.04	Line Speed Reference	RO	m/min (ft/min)	0-1999	-	
71.03	Line Speed Reference	RO	m/min (ft/min)	0-2 ³²		
15.05	Winder Speed	RO	r/min	0-1999	-	
15.50	Max Motor Speed	RO	r/min			
15.51						
16.38	Actual Motor Speed	RO	r/min			
16.39						
71.05	Actual Motor Speed	RO	r/min	0-2 ³²	-	
15.50	Maximum motor speed	RO	100 r/min	0-255		
15.51	Maximum motor speed	RO	r/min	0-99		
16.30	Speed reference polarity	RO	Bit	0-1	-	
15.36	Web break error flag	RO	Bit	0-1	-	
16.36	Watch dog trip	RO	Bit	0-1	-	
13.12	Contact control bit	RO	Bit	0-1	0	
71.08	Maximum Motor Speed	RO	r/min	-	-	
70.49	Software Version	RO	-	0 - 999999	-	

12.3.2 Diameter

No.	Description	Type	Units	Range	Default	Setting
15.16	Minimum diameter	RW	mm (0.1ins)	1-255 Alternative 70.04	1	
70.04	Minimum Diameter (Alternative register)	RW	mms (0.1ins)	1-2 ³²	1	
01.17	Maximum diameter	RW	mm (0.1ins)	15.16- 1000	1	
70.05	Maximum Diameter (Alternative register)	RW	mms (0.1ins)	1-2 ³²	1	
15.25	Select direct measurement of diameter via analogue input	RW	Bit	0-1	0	
07.03	Preset Diameter Analogue format	RW	PU	1-1000	1	
70.57	Analogue diameter signal min. value	RW	PU	0- [70.58]	0	
70.58	Analogue diameter signal max. value	RW	PU	[70.58] - 1000	1000	
15.30	Select preset diameter 2	RW	Bit	0 -1	0	
15.22	Select Diameter Set Point from parameter 15.17 or 1.19 Alternative 70.51 70.52 (15.30=1)	RW	Bit	0-1	0	
70.53	Select alternative preset diameter registers	RW	Bit	0-1	0	
15.17	Preset diameter value 1 15.30 = 0	RW	mm (0.1ins)	1-255	1	
70.51	Preset diameter 1 (Alternative register)	RW	mms (0.1ins)	1-2 ³²	1	
1.19	Preset diameter value 2 15.30 = 1	RW	mm (0.1ins)	1-1000	1	
70.52	Preset diameter 2 (Alternative register)	RW	mms (0.1ins)	1-2 ³²	1	
15.28	Preset diameter command bit	RW	Bit	0-1	0	
15.20.1	Diameter Calculation Mode	RW	Bit	0-1	0	
16.25	Reverse direction of diameter change under Lap count	RW	Bit	0-1	0	
16.26	End of traverse limit switch input for traverse mode	RW	Bit	0-1	0	
16.27	Select Traverse mode for diameter calculation	RW	Bit	0-1	0	
16.33	Hold diameter command bit	RW	Bit	0-1	0	
16.34	Select Quantum bit	RW	Bit	0-1	0	
15.11	Diameter Hold function speed threshold	RW	r/min	1-255	1	
15.20.4	Select fixed diameter slew limit	RW	Bit	0-1	0	

16.13	Fixed value for Diameter slew rate	RW	$\mu\text{m/s}$ (0.001ins/s)	1-255	1	
70.22	Winder Speed Sample Time	RW	ms	10-10000	10	
70.36	Slew hold diameter threshold	RW	$\mu\text{m/s}$ (0.001ins/s)	1-32000	200	
70.33	Acquire multiplier	RW	0.1 %	1-1000	1	
70.34	Enable acquire on start	RW	Bit	0-1	0	
15.24	Enable acquire	RW	Bit	0-1	0	
15.27	Enable Slack Web detection	RW	Bit	0-1	0	
70.32	Slack Web detection threshold	RW	0.1%	0-1000	0	
15.01	Current Radius display	RO	mm (0.1ins)	Min–Max diameter (1999)	-	
71.01	Current Diameter display Full range	RO	mm (0.1ins)	2^{32}		
15.02	Preset Radius value	RO	mm (0.1ins)	Min–Max diameter (1999)	-	
71.02	Preset Diameter display Full range	RO	mm (0.1ins)	2^{32}		
15.35	Diameter calculation error flag	RO	Bit	0-1	0	
15.40	Diameter Hold Flag	RO	Bit	0-q	-	
70.99	Non Volatile store for Actual Diameter	RO	mm	Min-Max diameter	-	

12.3.3 Speed Parameters

No.	Description	Type	Units	Range	Default	Setting
15.34	Speed Mode select	RW	Bit	0-1	0	
15.20.2	Select Dancer or Load cell operation	RW	Bit	0-4	0	
07.04	Load cell/Dancer feedback	RW	PU	0-1000	0	
16.20	Dancer Position Set point	RW	PU	0-255*4	0	
16.12	Centring Window	RW	PU	0-255	0	
13.09	Centring Speed	RW	m/min (ft/min)	0-255	0	
13.08	Centring Acceleration	RW	cm/min/s (ins/min/s)	0-255	0	
15.37	Enable coupling function	RW	Bit	0-1	0	
70.40	Coupling Speed Reference	RW	r/min	0-10	0	
70.41	Coupling Current Limit	RW	%	0-1000	0	
40.42	At Line Speed acceptance window Value	RW	m/min (ft/min)	0-Max speed	0	
16.35	Web Tensioned Flag	RO	Bit	0-1	-	
15.03	Required tension as per unit value use for E/P output	RO	PU	0-32000	-	

12.3.4 Torque Parameters

No.	Description	Type	Units	Range	Default	Setting
15.34	Speed Mode select	RW	Bit	0-1	0	
15.12 70.35	Offset speed	RW	m/min (ft/min)	0-255 (Max Speed)	0	
71.06	Actual Tension	RO	N (lbf)	0-2 ³²	-	
71.07	Tension feed forward	RO	N (lbf)	0-2 ³²	-	
16.01	Tension current component	RO	Amps	0-1999	-	

12.3.5 Tension

No.	Description	Type	Units	Range	Default	Setting
16.10	Maximum Tension Base value	RW	N (<i>lbf</i>)	1-1999	1	
16.11	Maximum Tension multiplier	RW	PU	1-255	0	
70.00	Maximum Tension (Alternative register)	RW	N (<i>lbf</i>)	0-2 ³²	1	
15.13	Percentage of Tension applied as Stall Tension	RW	%	0-100	0	
15.20.3	Set stall tension as percentage of Maximum tension	RW	Bit	0-1	0	
16.32	Select condition which switches from Stall to Run tension	RW	Bit	0-1	0	
70.11	Select Tension Set Point from parameter 70.08	RW	Bit	0-1	0	
07.01	Tension reference Analogue format	RW	PU	0-1000	0	
70.08	Tension Set point (Digital)	RW	N (<i>lbf</i>)	0-Max tension	0	
16.18	Tension reference ramp time	RW	s	0-255	1	
16.28	Hyperbolic Taper select	RW	Bit	0-1		
70.12	Select Taper set Point from parameter 70.09	RW	Bit	0-1	0	
07.02	Taper reference Analogue format	RW	PU	0-1000	0	
70.09	Taper Set point (Digital)	RW	%	0-100	0	
16.17	Diameter at which Taper Tension will start	RW	mm (<i>0.1ins</i>)	1-255	1	
16.22	Enable Lay On Roll tension boost	RW	Bit	0-1	1	
16.23	Enable Indexing tension boost	RW	Bit	0-1	1	
70.24	Index tension boost value as a percentage of operating tension	RW	0.10%	0-1000	1	
70.25	Lay On boost value as a percentage of maximum tension	RW	0.10%	0-1000	1	
71.09	Final Tension reference before taper	RO	N (<i>lbf</i>)	0-Max Tension	-	-
71.10	Initial Tension reference after taper	RO	N (<i>lbf</i>)	0-Max Tension	-	-

12.3.6 PID

No.	Description	Type	Units	Range	Default	Setting
07.04	Load cell / Dancer feedback	RW	PU	0-1000	0	
02.08	PID control P gain	RW	0.001Kp	0-1000	0	
70.14	PID control P gain (Alternative register)	RW	0.001Kp	0-2 ³²	0	
02.09	PID control I gain	RW	0.1Ki	0-1000	0	
70.15	PID control I gain (Alternative register)	RW	0.1Ki	0-2 ³²	0	
02.10	PID D Gain	RW	0.1Kd	0-1000	0	
70.16	PID D Gain (Alternative register)	RW	0.1Kd	0-2 ³²	0	
02.12	PID Filter	RW	-	0-1000	0	
02.11	Limit on PID output	RW	Tension-% Speed- cm/min (0.01ft/min)	0-1000 0-1000	0	
70.13	Select alternative registers	RW	Bit	0-1	0	
15.31	PID Enable	RW	Bit	0-1	0	
15.32	PID Hold integral	RW	Bit	0-1	0	
15.33	PID Reset integral	RW	Bit	0-1	0	
70.37	Start speed for PID gain profiler	RW	%	0-100	0	
16.03	PID error	RO	TorquePU Speed pos	+/-1000 +/-1999	-	
15.39	PID Output	RO	Torque – 0.1% Speed – cm/min (0.01ft/min)	0-1999	-	

12.3.7 Field Controller

No.	Description	Type	Units	Range	Default	Setting
06.07	Back EMF set point	RW	Volts	0-1000	0	
06.08	Maximum field current Used as field current demand in Back EMF mode	RW	PU	0-1000	1000	
06.10	Minimum field current	RW	PU	0-1000	500	
06.13	Enable field controller	RW	Bit	0-1	0	
15.20.7	Select as Back EMF winder	RW	Bit	0-1	0	
70.80 70.89	Field current profiler Diameter values	RW	Millimetres No Imperial option	0-Max diameter	0	
71.80 71.89	Field current demand values	RW	PU	0-1000	0	
70.56	Field Profiler Pointer	RO	-	0-10	0	

12.3.8 Compensation

No.	Description	Type	Units	Range	Default	Setting
04.11	Select compensation torque	RW	Bit	0-1	0	
15.21	Select compensation torque profiler	RW	Bit	0-1	0	
16.06	Material width	RW	mm (0.1ins)	1-1999	1	
70.02	Material width (Alternative register)	RW	mm (0.1ins)	1 - 2 ³²	1	
16.07	Material density divided by	RW	kgms/m ³ /10 (lb/ft ³ /10) kgms/m ³ (lb/ft ³)	1-1999	1	
70.03	Material density (Alternative register)	RW	kgms/m ³ (lb/ft ³)	1-2 ³²	1	
16.08	Mandrel inertia	RW	kgm ² (lb.ft ²)	0-1999	0	
16.19	Motor inertia	RW	kgm ² (lb.ft ²)	0-255	0	
16.15	Friction loss	RW	0.1%	0-255	0	
16.16	Viscous loss	RW	0.1%	0-255	0	
15.20.5	Select acceleration signal 0 = dn/dt on 15.04 1 = Read from 73.02	RW	Bit	0-1	0	
70.23	Analogue Line speed signal acceleration sample time	RW	10ms	1-100	1	
70.70 - 70.79	Compensation profiler Speed values	RW	r/min	0-max Motor r/ min	0	
71.70 - 71.79	Compensation profiler Torque values	RW	PU	0-1000	0	
16.05	Acceleration rate	RO	m/min/s (ft/min/s)	+/-32000	-	
16.02	Compensation current	RO	Amps	+/-1999	-	
70.55	Loss Profiler Pointer	RO	-	0 - 10	-	
15.38	Indication of Torque demand	RO	0.10%	0-255	-	
70.54	Indication of Torque demand	RO	PU	0-1000	-	

12.3.9 Digital Control Parameters

No.	Description	Type	Units	Range	Default	Setting
15.23	Tension ON	RW	Bit	0-1	0	
8.05	Run	RO	Bit	0-1	-	
8.02	Inch reverse command	RO	Bit	0-1	-	
8.03	Inch Forward command	RO	Bit	0-1	-	
13.12	Control word 1 bit 10	RO	Bit	0-1	0	
15.37	Coupling enable	RW	Bit	0-1	0	
73.70	Control word 0	RW	-	0-65535	0	
73.71	Control word 1	RW	-	0-65535	0	
72.70	Winder status word 1	RO	-	0-65535	-	
72.71	Winder status word 2	RO	-	0-65535	-	

13 Documentation Reference

Manual Description	CT Part Number
Mentor User Guide	0410 - 0009
MD29 User Guide	0400 - 0027
CTNet User Guide	0447 - 0009
Installation Guide MD29.UD70	0400 - 0030